

INTRODUCTION

A number of factors must be considered when planning where to place joints in a slab, such as the size of the slab, the location of rigid objects, and the slab thickness. You must also decide if the joints will be made as the concrete is placed or cut after the concrete has cured. In this unit you will learn the different types of joints, their uses, and how to properly place them so that the finished concrete will be serviceable for many years.

**FOCUS
ASSIGNMENTS**

FOCUS ASSIGNMENTS

1. Your instructor will show you a site where joint failure has occurred.
2. Write a brief description of something you learned during the field trip and share it with the class.



Interpersonal



Critical
Thinking

**UNIT
OBJECTIVE**

After completing this unit, you will show the following competencies by mastering the activities on the Assignment Sheet and by scoring at least 85% on the Written Test.

**SPECIFIC
OBJECTIVES**

1. Match types of basic joints to their purposes.
2. Identify types of control (contraction) joints.
3. Identify types of isolation (expansion) joints.
4. Identify types of construction joints.
5. Identify types of decorative joints.
6. Select from a list reasons for using joints in concrete slabs.
7. Name factors to consider when designing joint systems for slabs.



8. Select from a list variables to consider when deciding joint locations in slabs.
9. Name factors that affect the spacing of joints in slabs.
10. Label types of equipment used to cut joints.
11. Select from a list types of materials used in joints.
12. Select from a list types of sealants used in joints.
13. Label types of equipment used to apply sealants.
14. Arrange in order procedures used to maintain joint systems.
15. Identify types of waterstops.
16. Identify location of types of joints. (Assignment Sheet)



OBJECTIVE 1

Required Activities/
Resources
– Transparency

Optional Activities/
Resources in Instructor's
Guide

Match types of basic joints to their purposes.



Your instructor will show you a transparency of different types of joints used in concrete.

WORDS YOU SHOULD KNOW

- | | |
|-------------------------|---|
| joint | separation or cut made in concrete for a specific purpose |
| tensile strength | stress resulting from tension |

- **control (contraction)** — cut or formed to induce cracking at a designated point rather than at random
- **isolation (expansion)** — Required at points of potential stress to separate adjoining slabs at designated locations in order to isolate sections from one another and from other rigid objects
- **construction** — planned joint between two successive placements where a placement is temporarily suspended
- **decorative** — tooled joint used for decorative design purposes; in some instances may act as control joints

OBJECTIVE 2

Optional Activities/
Resources in Instructor's
Guide

Identify types of control (contraction) joints.

✓ **NOTE:** Control joints should be at least $\frac{1}{4}$ the depth of the slab and placed in accordance with specifications.

- Tooled control joint
- Sawed control joint

FIGURE 1

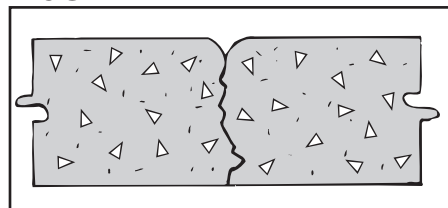
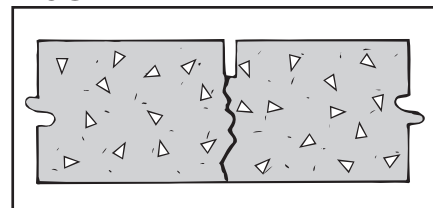
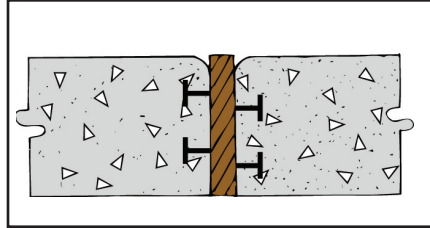

FIGURE 2



- Tooled control joint with wood divider strip

FIGURE 3



- Control joint with crack inducer anchored in the subgrade

FIGURE 4

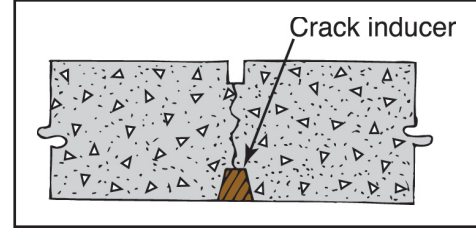

- Sawn contraction joint with smooth steel dowel (Figure 5)

FIGURE 5

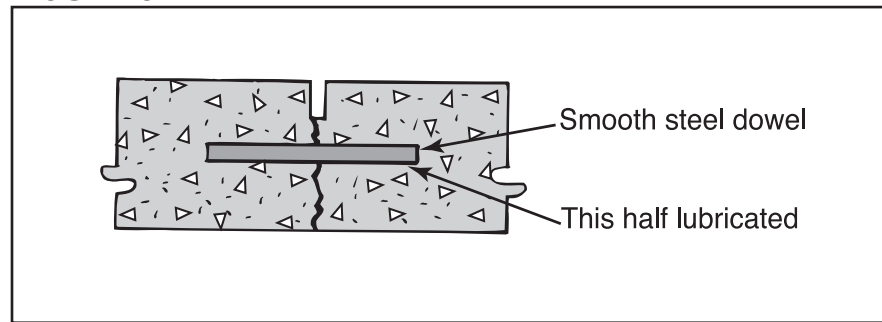

- Longitudinal joint

✓ **NOTE:** Longitudinal joints are control joints placed lengthwise in highway construction; they may be sawed, tooled, or keyed. (Figure 6)

FIGURE 6

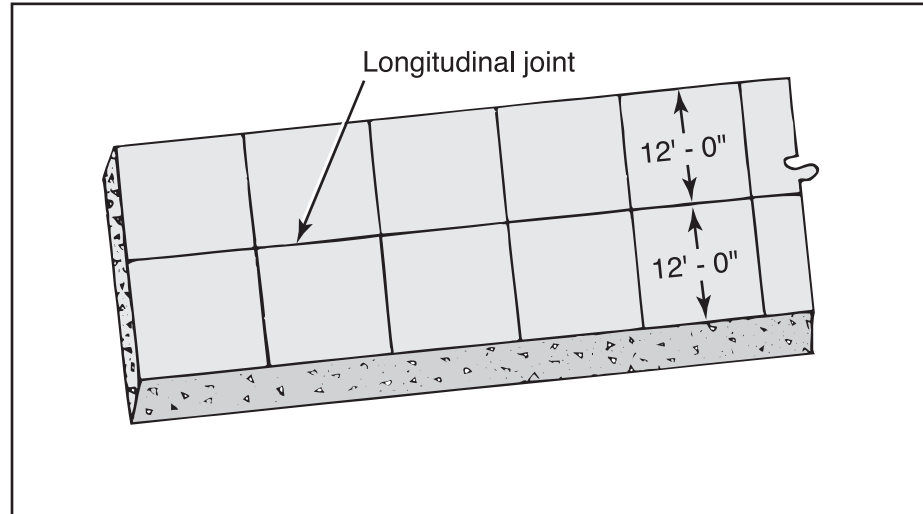

- Skewed joint

✓ **NOTE:** A skewed joint is one that does not run perpendicular to the form work. (Figure 7)

FIGURE 7

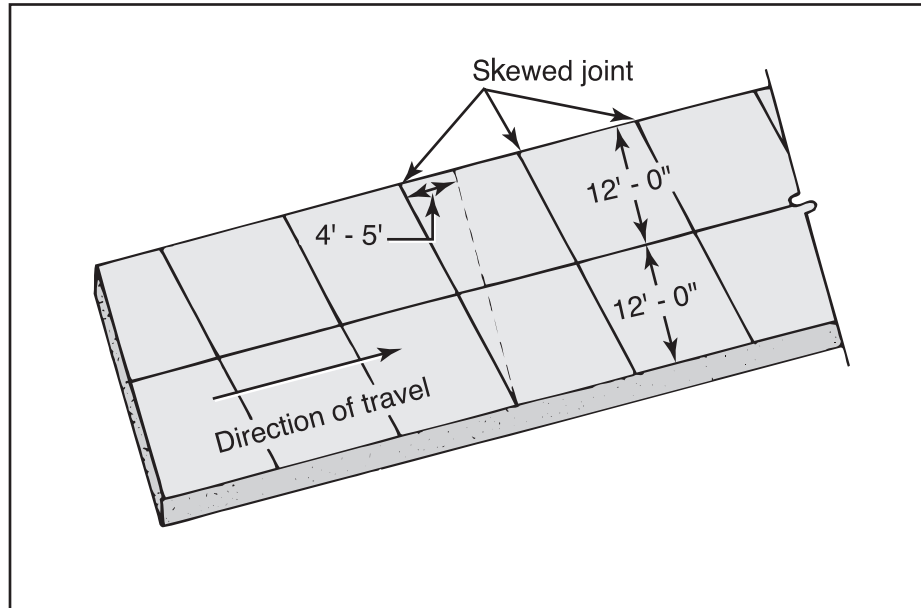

OBJECTIVE 3

Optional Activities/
Resources in Instructor's
Guide

Identify types of isolation (expansion) joints.

WORDS YOU SHOULD KNOW

expansion material

preformed piece of compressible material used to separate units of concrete to prevent damage due to expansion

sealant

elastic agent used to fill space in joints to prevent water and foreign materials from entering

- Tooled isolation joint with premolded expansion material (Figure 8)

FIGURE 8

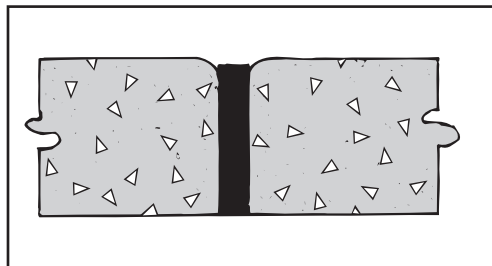

- Tooled isolation joint with premolded expansion material held down for sealant (Figure 9)

✓ **NOTE:** Premolded expansion material (cap) peels off prior to applying sealant.

FIGURE 9

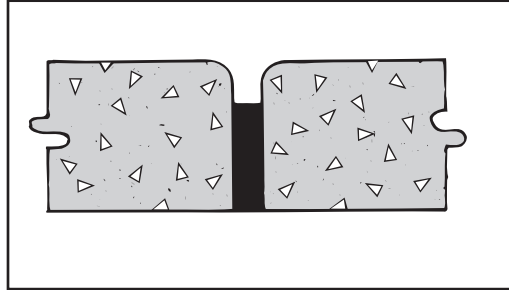

- Tooled isolation joint with premolded expansion material and a capped steel dowel (Figure 10)

FIGURE 10

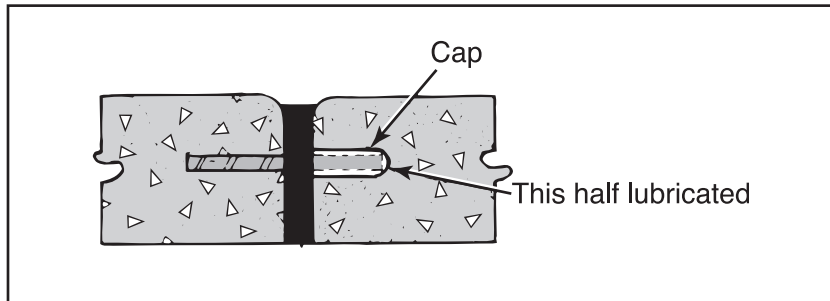

- Finger expansion joint (Figure 11)

FIGURE 11

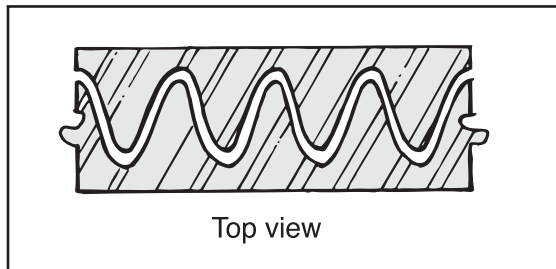

- Sliding plate expansion joint (Figure 12)

✓ **NOTE:** A sliding plate joint consists of a steel plate anchored to one section of concrete with another plate anchored to the adjoining section of concrete placed so that one will overlap and slip over the other.

FIGURE 12

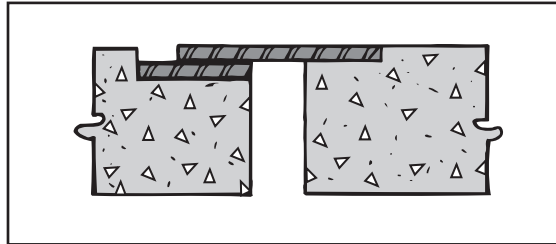

OBJECTIVE 4

Optional Activities/
Resources in Instructor's
Guide

Identify types of construction joints.

- Tooled or sawed butt joint (Figure 13)

FIGURE 13

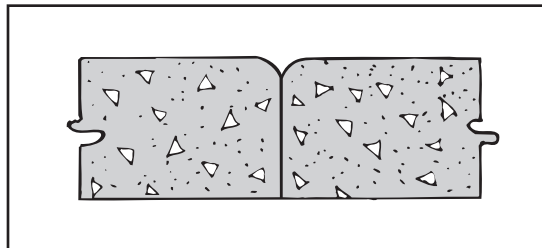

- Tooled or sawed butt joint with smooth steel rod (Figure 14)

FIGURE 14

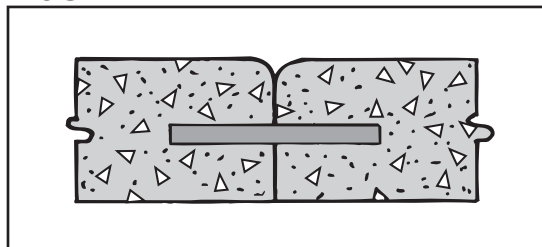

- Tooled joint with keyway (Figure 15)

FIGURE 15

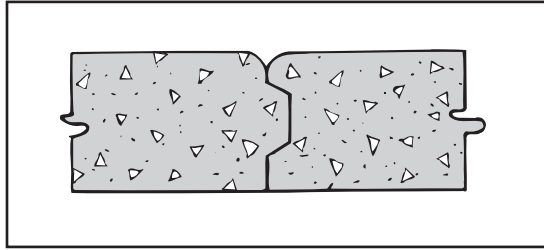

- Tooled joint with keyway and deformed steel rod (Figure 16)

FIGURE 16

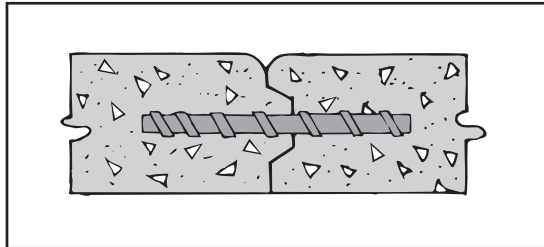

OBJECTIVE 5

Optional Activities/
Resources in Instructor's
Guide

Identify types of decorative joints.

- Tooled decorative joint (Figure 17)

FIGURE 17

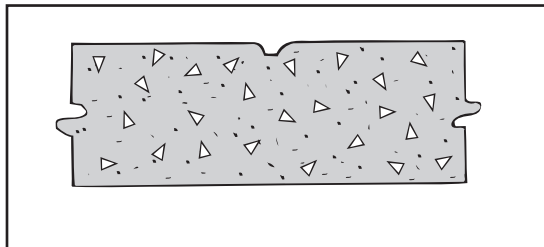

- Tooled decorative joint with wood strip (Figure 18)

FIGURE 18

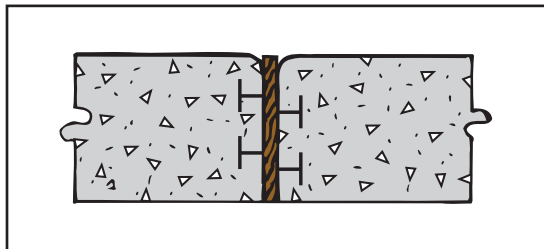

OBJECTIVE 6

Optional Activities/
Resources in Instructor's
Guide

Select from a list reasons for using joints in concrete slabs.

- To eliminate random cracks
- To allow expansion and contraction
- To separate adjoining parts at designed locations
- To temporarily separate two successive placements of concrete
- To allow stress relief
- To control transverse and longitudinal cracking
- To divide slabs into suitable spaces

OBJECTIVE 7

Optional Activities/
Resources in Instructor's
Guide

Name factors to consider when designing joint systems for slabs.

✓ **NOTE:** Joints should be laid out 2 to 3 times the depth of the slab and converted to feet. In a 4" slab, joints should have no more than 8 to 12 feet between joints.

- Types of cracks that may develop (Figure 19)

FIGURE 19

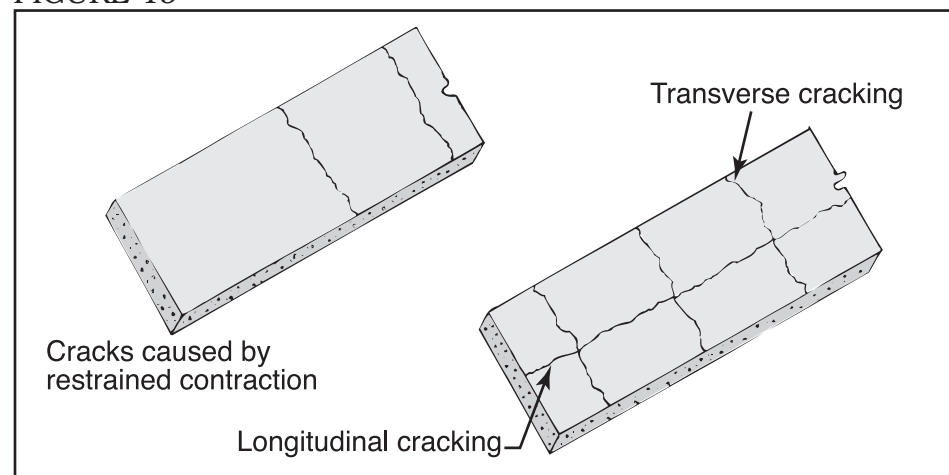

- How to control cracks
- How to provide adequate load transfer across joints
- How to prevent joints from faulting
- How to provide properly shaped sealant reservoirs
- How to provide adequate sealants to minimize infiltration into the joint



OBJECTIVE 8

Optional Activities/
Resources in Instructor's
Guide

Select from a list variables to consider when deciding joint locations in slabs.

- Tensile stress
- Slab size
- Vertical movement
- Horizontal movement
- Variations in slab thickness
- Locations of rigid objects

OBJECTIVE 9

Optional Activities/
Resources in Instructor's
Guide

Name factors that affect the spacing of joints in slabs.

WORDS YOU SHOULD KNOW

subgrade	soil prepared and compacted to support a structure, floor, or pavement system
-----------------	---

- Subgrade restraint
- Slab thickness
- Shrinkage potential of the concrete
 - ❑ Water content of concrete
 - ❑ Temperature and humidity
- Curing
- Absence of reinforcement

EXAMPLE: Rebar or wire mesh



OBJECTIVE 10

Optional Activities/
Resources in Instructor's
Guide

Label types of equipment used to cut joints.

- Jointer (groover) (Figure 20)

FIGURE 20



- Gasoline driven power saw (Figure 21)

FIGURE 21



- Electric worm driven saw with concrete blade (Figure 22)

FIGURE 22



- Ride-on power saw (Figure 23)

FIGURE 23



- Soff-cut saw (Figure 24)

FIGURE 24



- Cut-off saw (Figure 25)

FIGURE 25

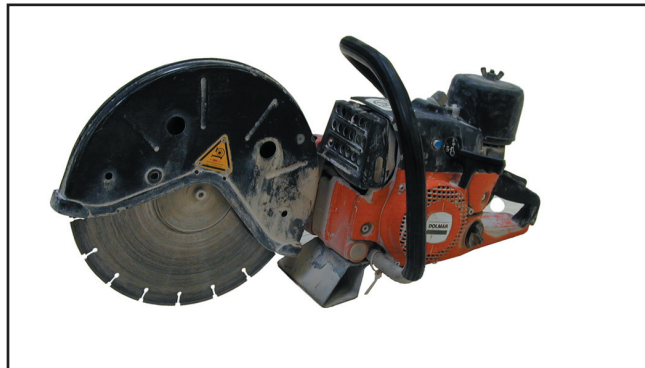

OBJECTIVE 11

Optional Activities/
Resources in Instructor's
Guide

Select from a list types of materials used in joints.

- Compressible (felt)
- Wood
- Plastic
- Metal
- Backer rod



OBJECTIVE 12

Optional Activities/
Resources in Instructor's
Guide

Select from a list types of sealants used in joints.

- **acrylic** — synthetic resin used for formulation of caulks and sealants with very good adhesion and weather resistant properties
- **elastomer** — elastic substance resembling rubber
- **low modulus epoxy** — semi-flexible epoxy used in joints to provide load transfer across joints
- **mastic** — any of various pasty materials composed of asphalts and nondrying oils
- **polyurea** — a fast-setting spray coating used in a variety of concrete applications
- **polyurethane** — nonstaining, durable, flexible elastomeric polymer compound
- **silicone** — polymeric organic compound used as a water resistant sealant
- **thermoplastic** — sealant material that becomes plastic upon heating

✓ **NOTE:** Other materials are available. Contact the local supplier in your area.

OBJECTIVE 13

Optional Activities/
Resources in Instructor's
Guide

Label types of equipment used to apply sealants.

- Spouted bucket for hot pour (Figure 26)

FIGURE 26

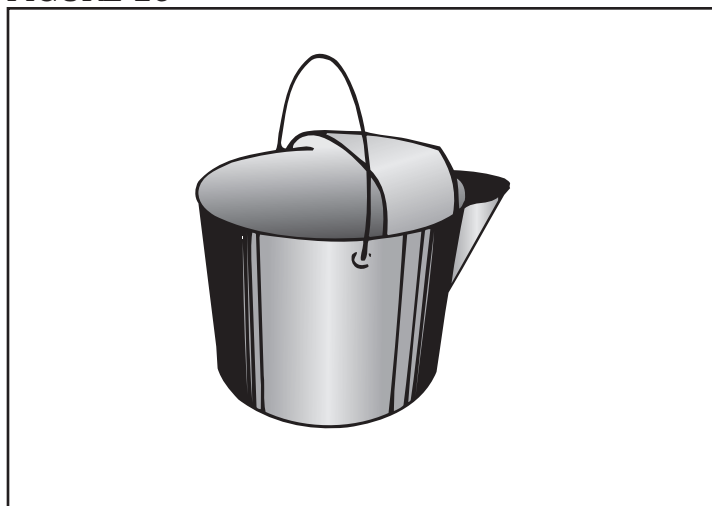

- Cartridge-type caulking gun (Figure 27)

FIGURE 27

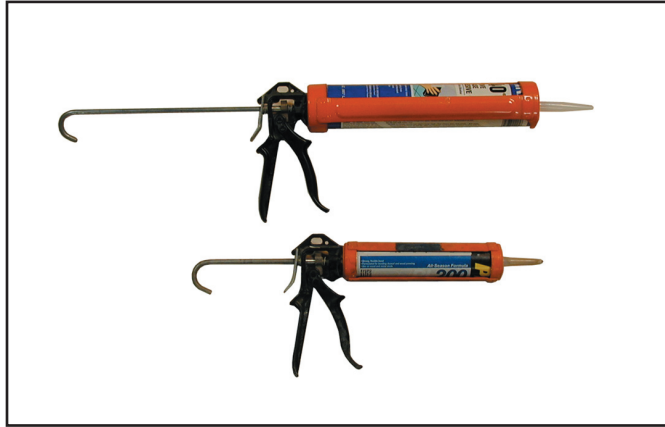

- Two-part gun (Figure 28)

FIGURE 28



- Sausage gun (Figure 29)

FIGURE 29

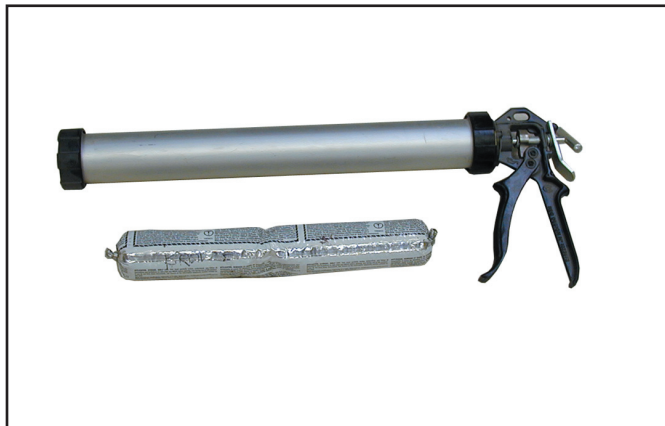

- Caulking knife (Figure 30)

FIGURE 30



OBJECTIVE 14

Optional Activities/
Resources in Instructor's
Guide

Arrange in order procedures used to maintain joint systems.

1. Schedule periodic inspections; examine existing caulking for discoloration or bonding separation
2. Cut or remove old sealant
3. Reface joint
4. Clean joint
5. Replace sealant



OBJECTIVE 15

Optional Activities/
Resources in Instructor's
Guide

Identify types of waterstops.

✓ **NOTE:** Waterstops are flexible waterproof material cast in place across joints in concrete to prevent the passage of water. (Figure 31)

FIGURE 31

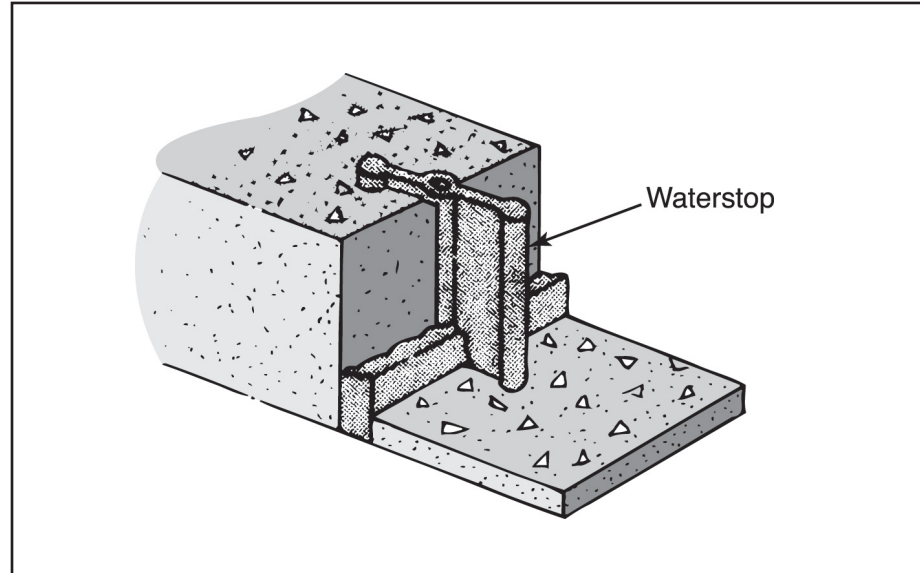

- Serrated

FIGURE 32

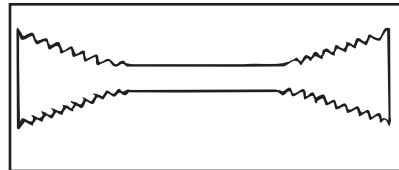

- Serrated "V"

FIGURE 34

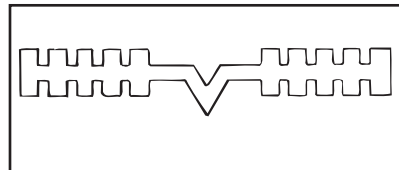

- Serrated dumbbell

FIGURE 33

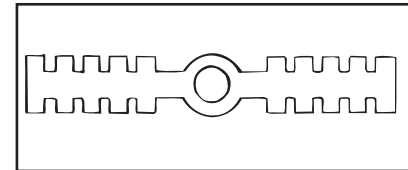

- Cellular

FIGURE 35

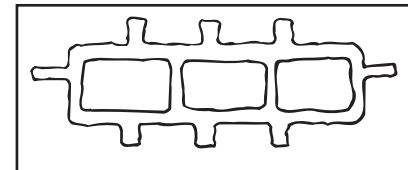

- Dumbbell

FIGURE 36

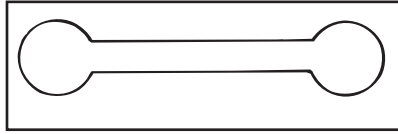

- On-grade

FIGURE 38

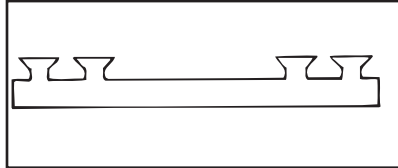

- Center-bulb dumbbell

FIGURE 37

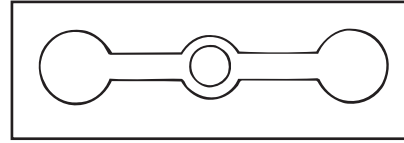

- Labyrinth

FIGURE 39

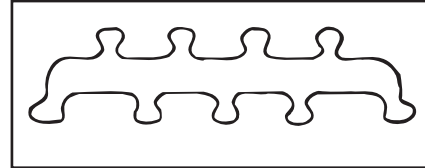

OBJECTIVE 16

Complete the Assignment Sheet.



Name _____ Score _____

OBJECTIVE 16

Identify location and types of joints.

BASIC SKILLS



Critical Thinking



Employability

INTRODUCTION

It is necessary for the cement mason to know proper jointing procedures in order to prevent random cracks in slabs. Practice identifying the locations of various types of joints by reviewing the Information Sheet, then complete the following exercise.

EQUIPMENT AND SUPPLIES

- Pen or pencil

INSTRUCTIONS

For each of the letters representing joints on the following floor plan, decide which type of joint should be used and write your answer in the blank provided. Some blanks may contain more than one answer.

- | | |
|----------|-----------|
| 1. _____ | 6. _____ |
| 2. _____ | 7. _____ |
| 3. _____ | 8. _____ |
| 4. _____ | 9. _____ |
| 5. _____ | 10. _____ |



