

**INTRODUCTION**

The layout of drives and approaches follows certain guidelines according to the type of driveway, its location, slope, and local codes and ordinances. A method of drainage will need to be determined and the types and locations of joints will need to be plotted. In this unit you will learn how to do all of these calculations and how to place and finish drives with curbs and curbs and gutters.

**FOCUS  
ASSIGNMENTS****FOCUS ASSIGNMENTS**

1. Bring in pictures of drives, approaches, curbs, and curbs and gutters.
2. Participate in a class discussion about the different types, slopes, finishes, and joints.



Interpersonal



Employability

**UNIT  
OBJECTIVE**

After completing this unit, you will show the following competencies by mastering the activities on the Job Sheets and by scoring at least 85% on the Written Test.

**SPECIFIC  
OBJECTIVES**

1. Name types of drives and approaches.
2. Select from a list factors to consider prior to laying out an approach.
3. List guidelines for width and slope of drives and approaches.
4. Identify types of finishes for residential drives and approaches.
5. Identify types of joints used on drives and approaches.
6. Match types of joints to their locations on drives and approaches.
7. Explain briefly concrete thickness variations for drives and approaches.



8. Name methods used to drain driveways.
9. Identify types of curbs and curbs and gutters.
10. Place and finish concrete for a driveway. (Job Sheet 1)
11. Place and finish concrete for a drive with curbs. (Job Sheet 2)
12. Place and finish concrete for a straight curb. (Job Sheet 3)
13. Place and finish concrete for a roll-type curb and gutter. (Job Sheet 4)



**OBJECTIVE 1**

Optional Activities/  
Resources in Instructor's  
Guide

**Name types of drives and approaches.**

<b>WORDS YOU SHOULD KNOW</b>	
<b>approach</b>	entrance to a drive

- Residential
- Commercial

**OBJECTIVE 2**

Required Activities/  
Resources  
— Transparencies 1 and 2

Optional Activities/  
Resources in Instructor's  
Guide

**Select from a list factors to consider prior to laying out an approach.**



Your instructor will display transparencies that show residential and commercial approaches.

- Type
- Location
- Design
- Size
- Use
- Slope
- Codes and ordinances

EXAMPLES: Federal, state, city, county



### OBJECTIVE 3

Optional Activities/  
Resources in Instructor's  
Guide

#### List guidelines for width and slope of drives and approaches.

- Width
  - ❑ Width for single car garages will vary from 10 to 14 feet
  - ❑ Width for double car garages will vary from 16 to 24 feet
- ✓ **NOTE:** Curving drives should be a minimum of fourteen feet wide and at least three feet wider than the widest vehicle they serve. Short drives should be full width their entire length, but long drives may be single car width so long as they widen as they approach the garage in order to provide access to both sides of the garage.
- Slope
  - ❑ Maximum grade of slope should be no more than 14 percent or  $1\frac{3}{4}$  inch vertical rise per foot of run. (Figure 1)

FIGURE 1

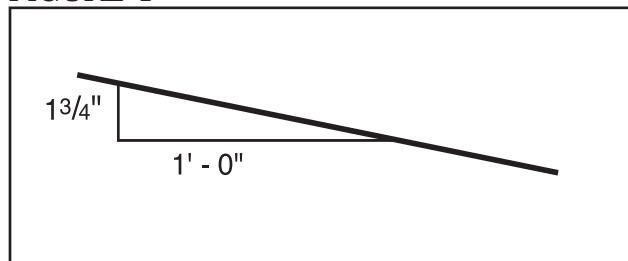

- ❑ Change in grade should be gradual enough to avoid scraping the vehicle's bumper or underside. (Figure 2)

✓ **NOTE:** The most critical point occurs when the rear wheels are in the gutter as the vehicle enters the drive from the street.

FIGURE 2

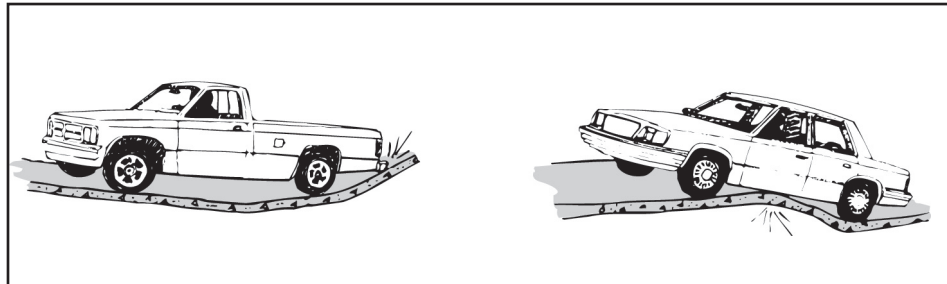

- ❑ A simple jig can be constructed from framing material to determine if a vehicle will pass over the slope of the driveway. (Figure 3)

FIGURE 3

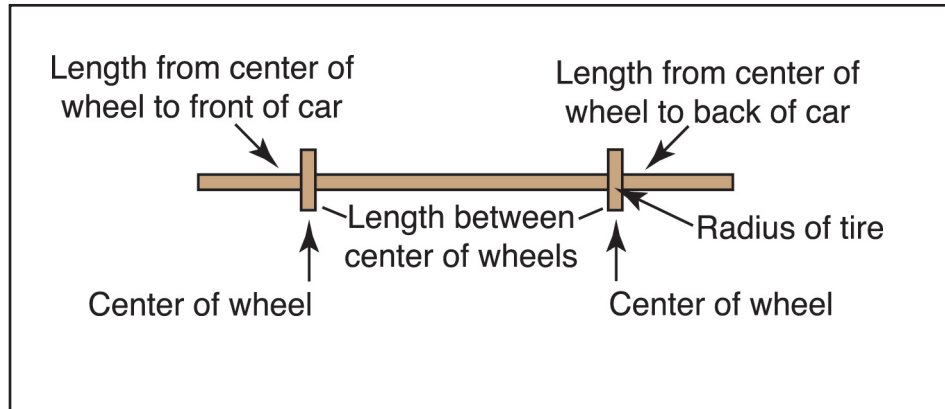

## OBJECTIVE 4

Optional Activities/  
Resources in Instructor's  
Guide

### Identify types of finishes for residential drives and approaches.

- Broom (Figure 4)

FIGURE 4



- Float/trowel (Figure 5)

FIGURE 5



- Exposed aggregate (Figure 6)

✓ **NOTE:** This finish is obtained by embedding a special aggregate into the surface and then exposing the aggregate with a brush and wash process.

FIGURE 6



- Stamped (Figure 7)

FIGURE 7



- Stencil (Figure 8)

FIGURE 8



Photo courtesy of Artcrete, Inc. Natchitoches, LA.



## OBJECTIVE 5

Optional Activities/  
Resources in Instructor's  
Guide

### Identify types of joints used on drives and approaches.

- Construction

✓ **NOTE:** A construction joint is a planned joint between two successive placements where one is temporarily suspended.

- Tooled or sawed butt joint (Figure 9)

FIGURE 9

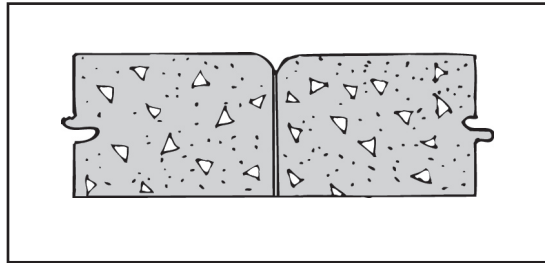

- Tooled or sawed butt joint with smooth steel rod (Figure 10)

FIGURE 10

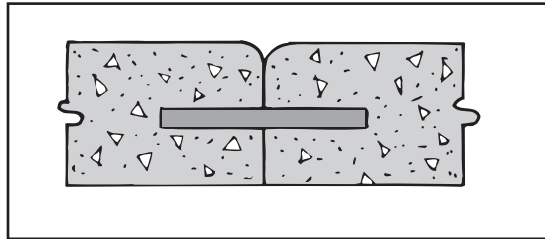

- Tooled joint with keyway (Figure 11)

FIGURE 11

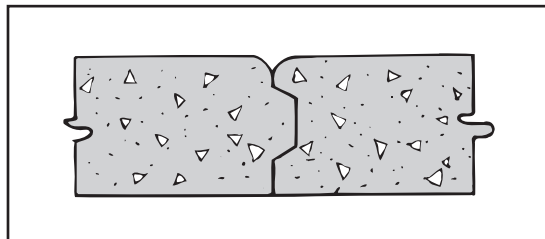

- Tooled joint with keyway and deformed steel rod (Figure 12)

FIGURE 12

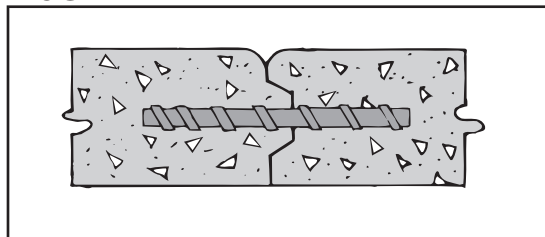

- Control

✓ **NOTE:** A control joint is cut or formed to induce cracking at the joint rather than at random. The cracked area beneath control joints is called “Aggregate Interlock” and behaves much like a narrow keyway.

- Tooled control joint (Figure 13)

FIGURE 13

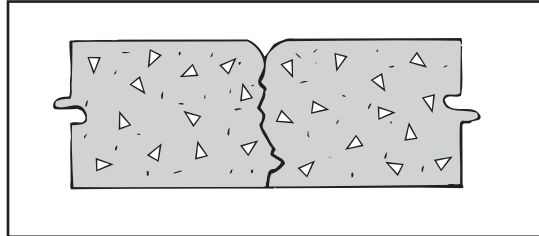

- Sawn control joint (Figure 14)

FIGURE 14

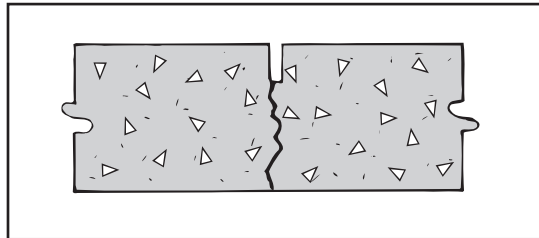

- Tooled control joint with wood divider strip (Figure 15)

FIGURE 15

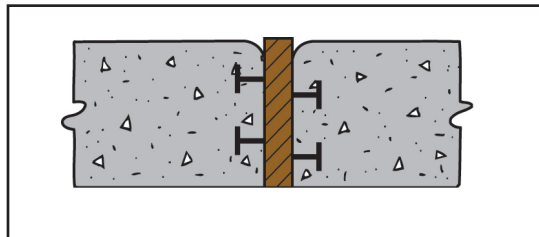

- Isolation (expansion)

✓ **NOTE:** Isolation joints are required at points of potential stress to isolate sections from one another and from other rigid objects.

- Tooled joint with premolded expansion material (Figure 16)

FIGURE 16

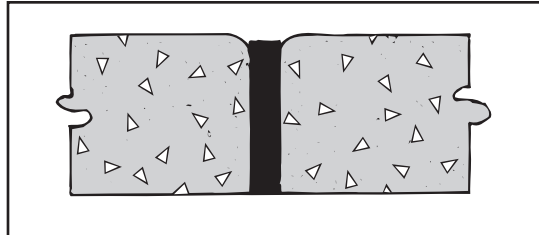

- Tooled joint with premolded expansion material held down for sealant (Figure 17)

✓ **NOTE:** Premolded expansion material (cap) peels off prior to applying sealant.

FIGURE 17

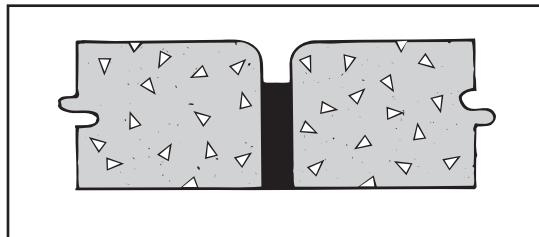

- Tooled joint with premolded expansion material and capped steel rod (Figure 18)

FIGURE 18

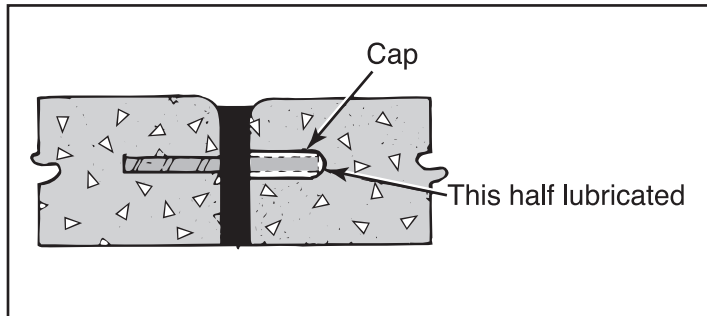

- **Decorative**

✓ **NOTE:** Decorative joints may also act as control joints in some instances.

- Tooled decorative joint (Figure 19)

FIGURE 19

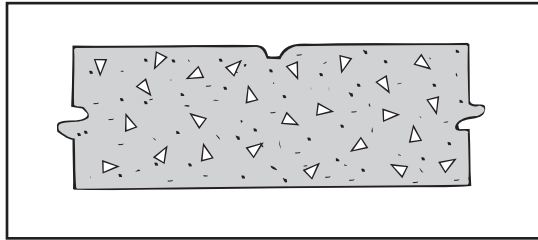

- Tooled decorative joint with wood spacer (Figure 20)

FIGURE 20

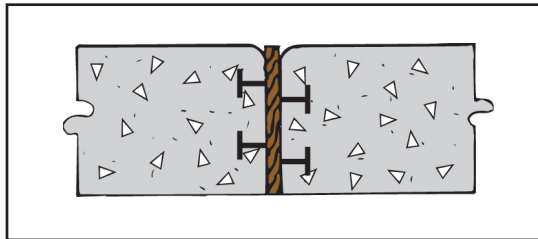

- Tooled open joint for filling (Figure 21)

FIGURE 21

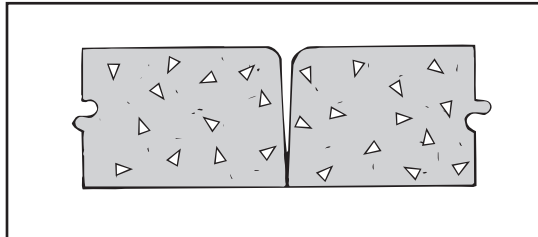

- Longitudinal

✓ **NOTE:** Longitudinal joints are usually placed lengthwise in drives and approaches that are twelve feet wide or over.

- Tooled decorative joint (Figure 22)

FIGURE 22

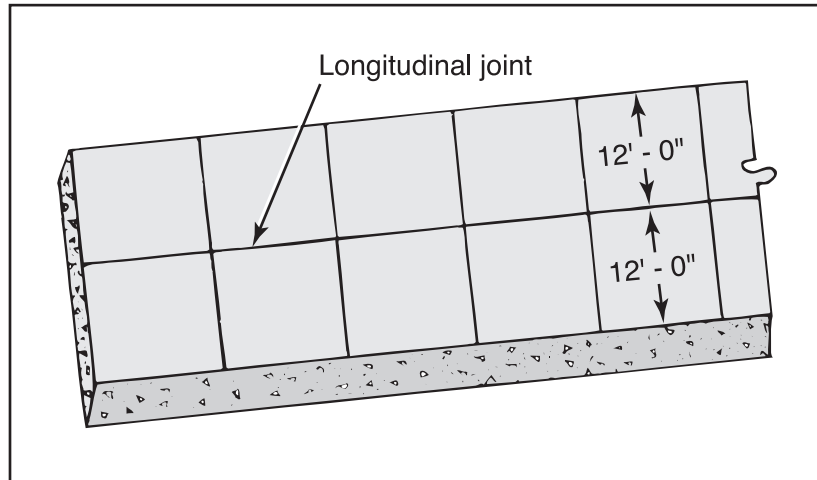

## OBJECTIVE 6

Required Activities/  
Resources  
— Transparency 3

Optional Activities/  
Resources in Instructor's  
Guide

**Match types of joints to their locations on drives and approaches.**



Your instructor will display a transparency that shows joints used in drives and approaches.

- **Control joints**

- Spaced at intervals about equal to width of drive
- Spaced at intervals about equal to one-half width of drive when longitudinal joint is used through the center
- Lengthwise of drives or approaches when width exceeds twelve feet; they should be evenly spaced across slab

- **Isolation (expansion) joints**

- Points of potential stress
- Intersections of concrete

EXAMPLES: Where drives and approaches adjoin sidewalks, curbs and other slabs

- **Construction joints** — Where placement is temporarily suspended



## OBJECTIVE 7

Optional Activities/  
Resources in Instructor's  
Guide

- **Decorative joints** — To create decorative patterns
- **Longitudinal joints** — Lengthwise of drives or approaches when width exceeds twelve feet; should be evenly spaced across slab

### Explain briefly concrete thickness variations for drives and approaches.

- Residential
  - ❑ Four-inch minimum
  - ❑ Increased to five or six inches if drive or approach is subjected to heavy truck traffic
- Commercial
  - ❑ Six-inch minimum
  - ❑ Increased to eight inches if drive or approach is subjected to extra-heavy truck traffic

## OBJECTIVE 8

Required Activities/  
Resources  
— Transparency 4

Optional Activities/  
Resources in Instructor's  
Guide

### Name methods used to drain driveways.



Your instructor will display a transparency that shows methods of drainage for driveways.

- Place and finish concrete for a drive with a crown in the center (Figure 23)

✓ **NOTE:** This will allow water to drain off on both sides of the drive.

FIGURE 23

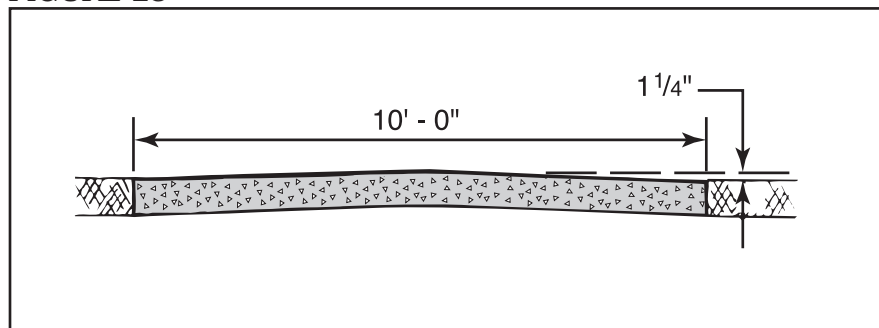

Used with permission of Portland Cement Association.



- Place and finish concrete for a drive with an inverted crown in the center (Figure 24)
- ✓ **NOTE:** This will allow water to drain to the center of drive and then drain off the low end.

FIGURE 24

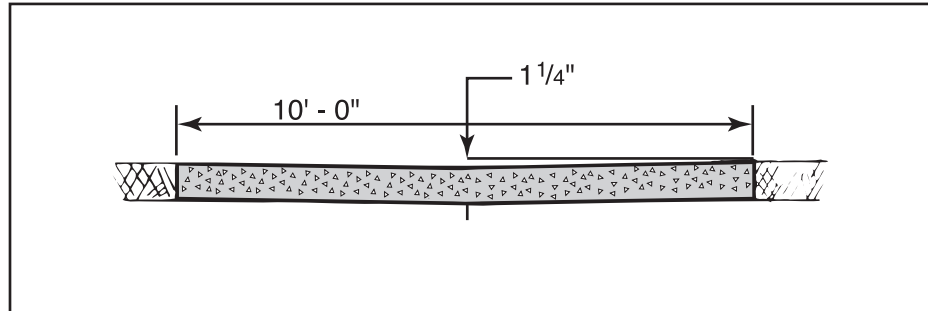

Used with permission of Portland Cement Association.

- Place and finish concrete for a drive with a cross slope (Figure 25)
- ✓ **NOTE:** This will allow water to drain off onto the low side of the drive.

FIGURE 25

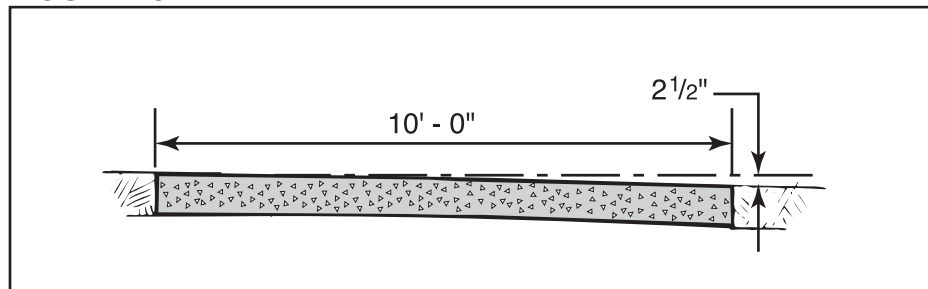

Used with permission of Portland Cement Association.



## OBJECTIVE 9

Optional Activities/  
Resources in Instructor's  
Guide

### Identify types of curbs and curbs and gutters.

#### WORDS YOU SHOULD KNOW

**batter**

a receding upward slope of the face of a form or structure

- Curbs

- Straight

FIGURE 26

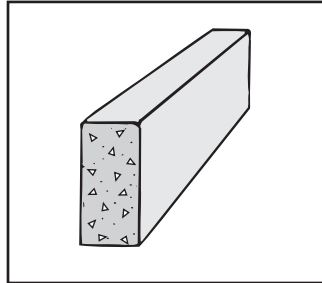

- Fully battered

FIGURE 27

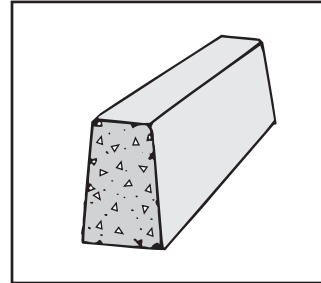

- Partially battered

FIGURE 28

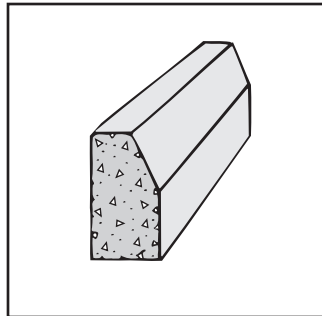

- Precast

FIGURE 29

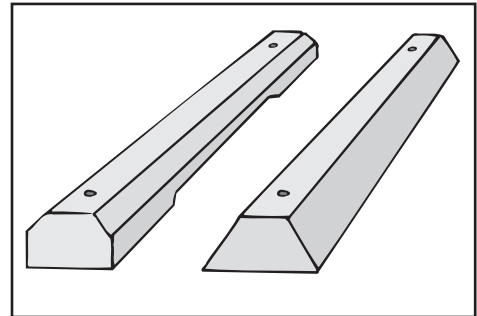

- Curbs and gutters

- Straight face, vertical

FIGURE 30

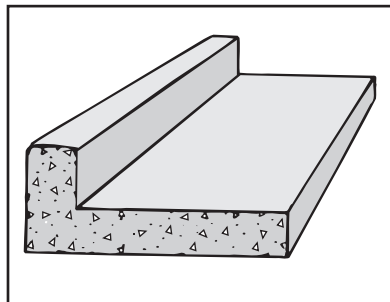

- Straight face, battered

FIGURE 31

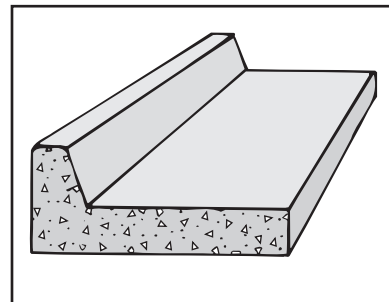

- ❑ Single radius, vertical

FIGURE 32

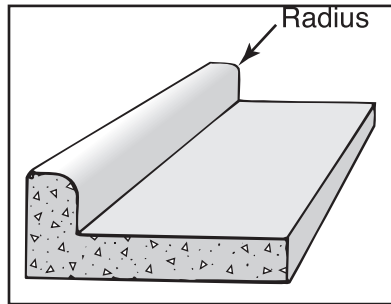
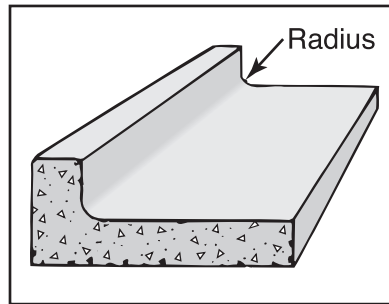

FIGURE 33



- ❑ Single radius, battered

FIGURE 34

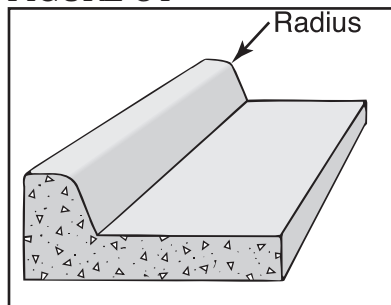
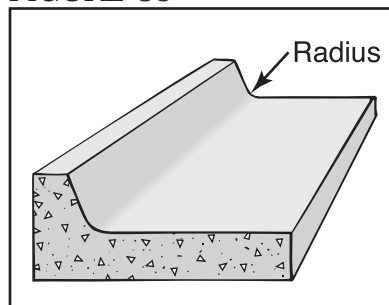

FIGURE 35



- ❑ Double radius, vertical

FIGURE 36

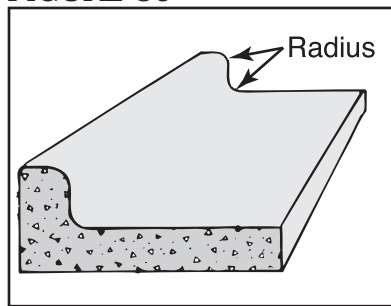
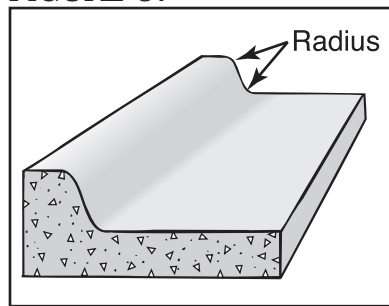
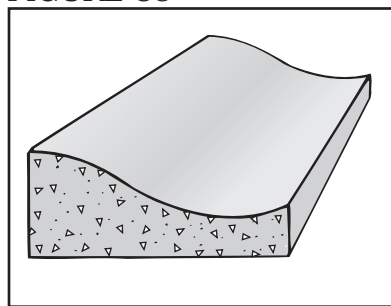

FIGURE 37



- ❑ Roll-type

FIGURE 38



- ❑ Highway gutter

FIGURE 39

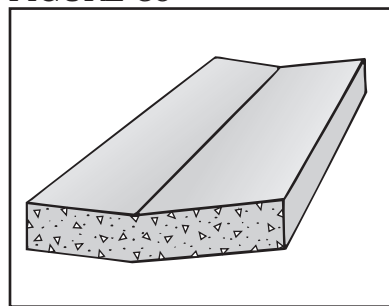

**OBJECTIVE 10**      **Complete Job Sheet 1.**

**OBJECTIVE 11**      **Complete Job Sheet 2.**

**OBJECTIVE 12**      **Complete Job Sheet 3.**

**OBJECTIVE 13**      **Complete Job Sheet 4.**





Name \_\_\_\_\_ Score \_\_\_\_\_

**OBJECTIVE 10**

**Place and finish concrete for a driveway.**

**BASIC SKILLS**



Employability

**EQUIPMENT  
AND SUPPLIES**

- Straightedge
- Bullfloat
- Hand floats
- Trowels
- Margin trowel
- Edger with ½" radius
- Broom
- Sprayer
- Concrete
- Bucket of water
- Curing agent
- Knee boards
- Personal protective equipment

✓ **NOTE:** Refer to C.F.R 1926.28 Sub Part C in regard to personal protective equipment.



## PROCEDURE

Yes No

1. Place the concrete at the starting point. (Figure 1)

FIGURE 1

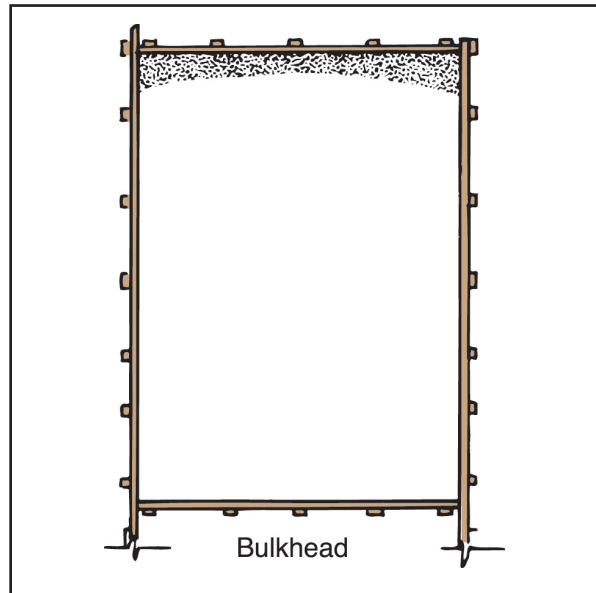

2. Use a straightedge with a sawlike motion to rod concrete.

✓ **NOTE:** Be sure to keep enough concrete in front of the straightedge to fill holes.

3. Start bullfloating as soon as there is room behind the straightedge. (Figure 2)

✓ **NOTE:** Bullfloat the surface of the drive with a forward and backward movement.



FIGURE 2

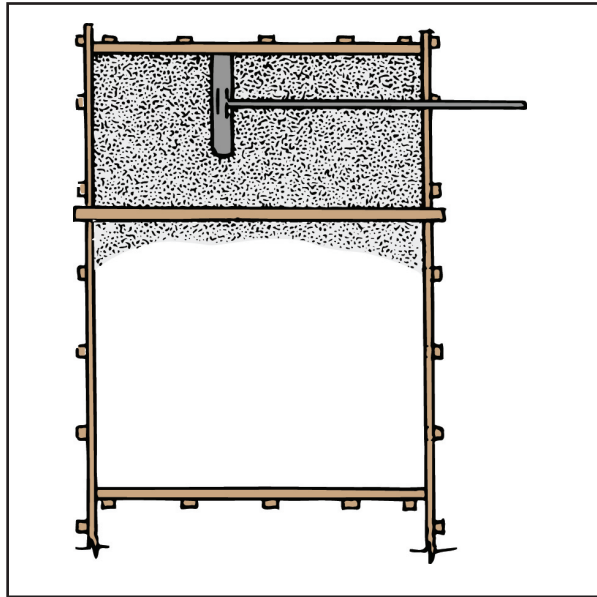

Yes No

4. Continue straightedging and bullfloating until the entire slab has been bullfloated. (Figure 3)

FIGURE 3

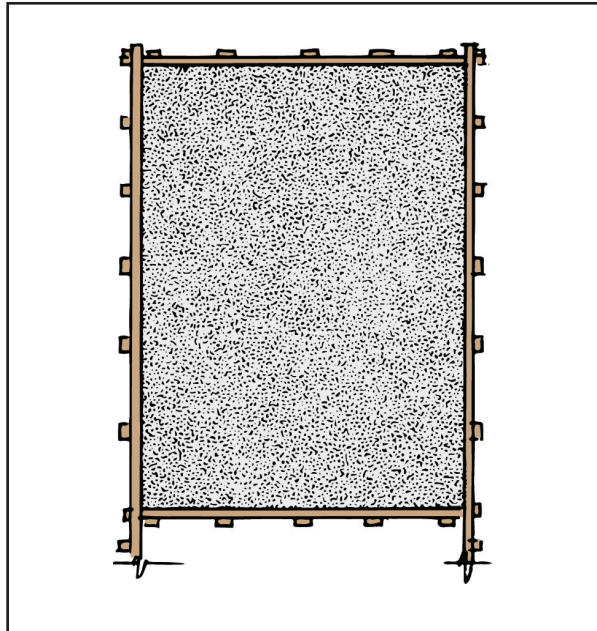

**Yes No**

5. Prepare the edge.

✓ **NOTE:** The edge should be floated or hand darbied level prior to edging.

6. When the concrete is hard enough, edge the entire perimeter of the slab.

7. To edge, tilt the front of the edger slightly up and move it forward in an arm's length pattern along the edge of the form.

✓ **NOTE:** To avoid picking up the surface of the concrete, lift the edger only when it is still in motion.

8. Extend the edger at arm's length and draw it backward with the back of the edger tilted up slightly.

✓ **NOTE:** To avoid picking up the surface of the concrete, lift the edger only when it is still in motion.

9. Continue this procedure until edging is complete.

10. When the concrete is hard enough, start laying down the drive, starting along the edge of the hardest section.

11. Float the edges with the float relatively flat and at arm's length, moving the float in a wide semicircular motion until the surface is smooth and free of high and low places.

12. Trowel the edges of the concrete with a finishing trowel immediately after floating each area.

13. Position the trowel relatively flat at arm's length, move the trowel in wide semicircular motion, troweling the slab until the surface is smooth.

14. Continue floating and troweling until the edge is completed.

15. When the concrete is hard enough to work, place knee boards on the slab; float and trowel the entire slab until the surface is smooth and free of high and low places.



**Yes No**

- 16. Re-edge all the edges following the same procedures as in steps 7 through 9.
- 17. Start the broom finish by extending the broom to the far edge and pulling it across the slab.
- 18. Swing the broom to the opposite edge and pull it across the slab, slightly overlapping the preceding pass.
- 19. Continue this procedure until the slab is completely broomed.
- 20. Re-edge the slab, again following the procedures in steps 7 through 9.

✓ **NOTE:** Be extra cautious not to put too much pressure on the edger; this could cause an unsightly ridge on the finished driveway.

- 21. Apply a curing agent using a sprayer with the nozzle adjusted to a fine mist.
- 22. Have the instructor check your work.
- 23. Clean the work area and return tools and equipment to proper storage.

✓ **NOTE:** Be sure to wash the broom thoroughly in clean water.



## SKILL TEST RECORD

### PRODUCT EVALUATION

**Evaluator note:** Rate the student on the following criteria by circling the appropriate numbers. Each criterion must receive a rating of “3” or higher to demonstrate student mastery. (See Key below.) A student who is unable to demonstrate mastery should review the material and submit another product for evaluation.

Criteria:

Safety	4	3	2	1
Use of tools	4	3	2	1
General appearance	4	3	2	1
Overall performance	4	3	2	1

### AVERAGE RATING

**Evaluator note:** To obtain an average rating for the Profile of Training Mastery, total the points in Product Evaluation and divide by the total number of criteria. Circle the rating on the Key.

### KEY

- 4 Skilled** — Can perform job with no additional training
- 3 Moderately Skilled** — Has performed job during training program; limited additional training may be required
- 2 Limited Skill** — Has performed job during training program; additional training is required to develop skill
- 1 Unskilled** — Is familiar with process, but is unable to perform job

### EVALUATOR'S COMMENTS

---

---

---



Name \_\_\_\_\_ Score \_\_\_\_\_

**OBJECTIVE 11**

**Place and finish concrete for a drive with curbs.**

**BASIC SKILLS**



Employability

**EQUIPMENT  
AND SUPPLIES**

- Straightedge
- Bullfloat
- Hand floats
- Small trowel
- Brush
- Margin trowel
- Edger with ½" radius
- Edger with 1½" radius
- Walking edger
- Broom
- Sprayer
- Concrete
- Bucket of water
- Curing agent
- Hammer
- Knee boards
- Personal protective equipment

✓ **NOTE:** Refer to C.F.R 1926.28 Sub Part C in regard to personal protective equipment.

**PROCEDURE**

✓ **NOTE:** Curbs are placed and floated and a wet screed established at the base of the curb before placing the driveway.

**Yes No**

1. Float off the curbs to the tops of the forms.

✓ **NOTE:** Wait to edge until the truck is dumped out.

2. Float to the base of the curb to establish the grade of the wet screed.

✓ **NOTE:** Pour the base of the curb wide enough to establish a good rodding surface.



**Yes No**

3. Straight edge after floating the base in order to correct any floating mistakes and establish a true line.

✓ **NOTE:** When straightedging, be aware of grade transitions.

4. Place the concrete at the starting point of the drive. (Figure 1)

FIGURE 1

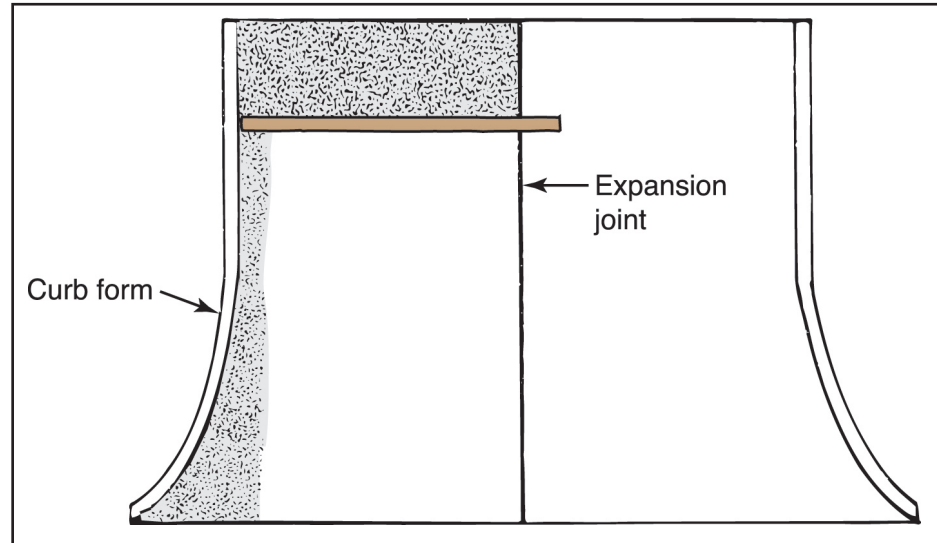

5. Use a straightedge with a sawlike motion to rod the concrete. (Figure 2)

FIGURE 2

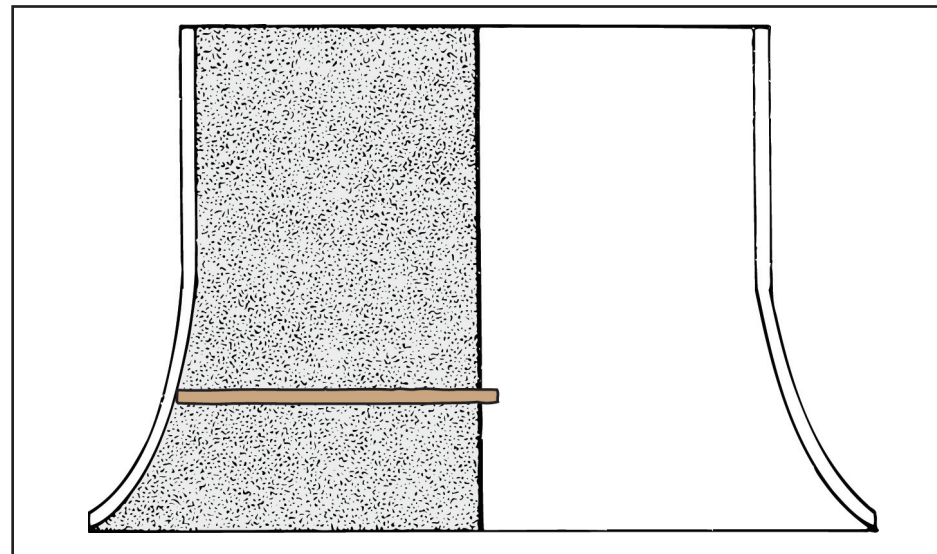

**Yes No**

6. Continue straightedging and backing up until the drive is placed.

7. Bullfloat the surface of the drive with a forward and backward movement.

✓ **NOTE:** This step should be done immediately after straightedging.

A. Position the handle of the bullfloat so the front of the blade is slightly tilted up on the forward motion.

B. Position the handle of the bullfloat so that the rear of the blade is relatively flat to the surface on the backward motion.

C. Make another pass over the first pass; this time make the backward motion with the handle positioned so that the rear of the blade is slightly raised.

D. Slightly overlap the previous pass and continue the process until the entire slab has been bullfloated.

8. Use a sidewalk edger to edge the rear of the curbs, expansion joint, and the other edges.

A. To edge, tilt the edger slightly up and move it forward in an arm's length pattern.

✓ **NOTE:** To avoid picking up the surface of the concrete, lift the edger only while it is still in motion.

B. Extend the edger at arm's length and draw backward with the edger tilted up slightly.

✓ **NOTE:** To avoid low places, do not put too much pressure on edger. This is "rolling" the edge.

C. Continue this procedure until all the curbs have been rounded and smoothed.

9. Edge the face of the curb using a 1½" edger.



**Yes No**

10. Remove the stakes and the inside of curb forms with a hammer.

✓ **NOTE:** Only remove one portion of the forms at a time and finish. Avoid exposing too much face to the air.

11. Finish the face of the curb, closing holes and leaving it relatively smooth.

12. Continue this procedure until the curb is finished.

13. Brush up the face and over the curb. (Figure 3)

14. Float and trowel the slab before applying finish to the surface.

FIGURE 3

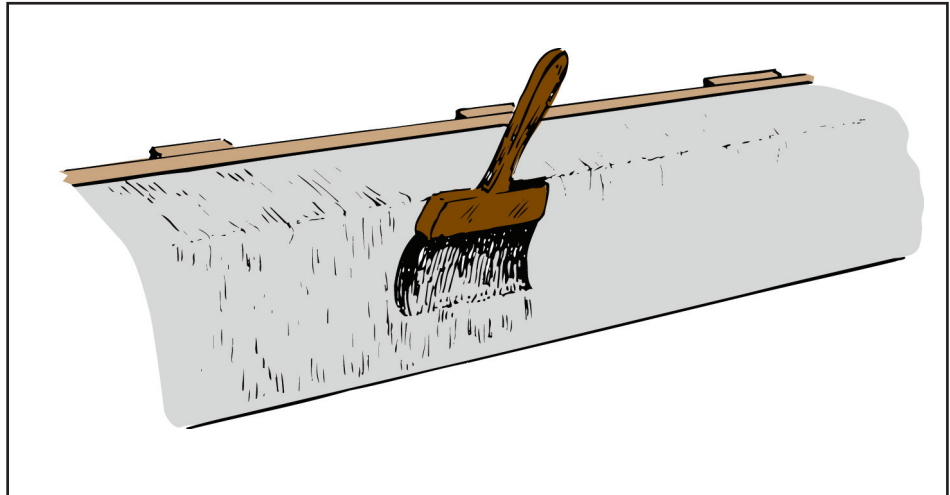

15. When the concrete is hard enough, apply a broom or appropriate tractional finish as specified.

16. Apply a curing agent as soon as possible without damaging the finish.

17. Use a margin trowel, brush, and water to clean all the tools and equipment.

18. Have the instructor check your work.

19. Clean the work area and return tools and equipment to proper storage.



---

## SKILL TEST RECORD

### PRODUCT EVALUATION

**Evaluator note:** Rate the student on the following criteria by circling the appropriate numbers. Each criterion must receive a rating of “3” or higher to demonstrate student mastery. (See Key below.) A student who is unable to demonstrate mastery should review the material and submit another product for evaluation.

Criteria:

Safety	4	3	2	1
Use of tools	4	3	2	1
General appearance	4	3	2	1
Overall performance	4	3	2	1

### AVERAGE RATING

**Evaluator note:** To obtain an average rating for the Profile of Training Mastery, total the points in Product Evaluation and divide by the total number of criteria. Circle the rating on the Key.

### KEY

- 4 Skilled** — Can perform job with no additional training
- 3 Moderately Skilled** — Has performed job during training program; limited additional training may be required
- 2 Limited Skill** — Has performed job during training program; additional training is required to develop skill
- 1 Unskilled** — Is familiar with process, but is unable to perform job

### EVALUATOR'S COMMENTS

---

---

---





Name \_\_\_\_\_ Score \_\_\_\_\_

**OBJECTIVE 12**

**Place and finish concrete for a straight curb.**

**BASIC SKILLS**



Employability

**EQUIPMENT  
AND SUPPLIES**

- Hand float
- Curb edger with 1½" radius
- Sidewalk edger with ¾" radius
- Brush
- Margin trowel
- Small trowel
- Jointer
- Hammer
- Sprayer
- Concrete
- Curing agent
- Personal protective equipment

✓ **NOTE:** Refer to C.F.R 1926.28 Sub Part C in regard to personal protective equipment.



## PROCEDURE

✓ **NOTE:** Place control joints and expansion joints where necessary or according to specifications.

### Yes No

1. Place the concrete at the starting point and consolidate properly. (Figure 1)

FIGURE 1

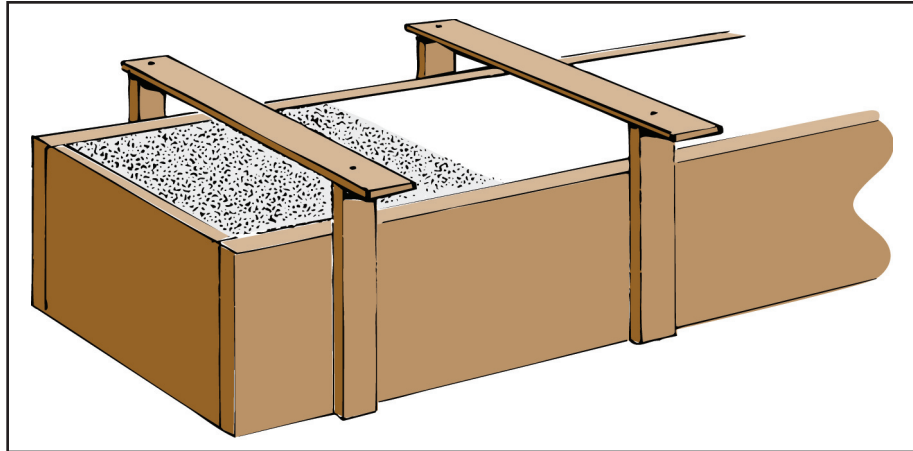

2. Continue placing the concrete in the curb form and float the surfaces flush with the top of the forms until the entire curb is placed and floated.

✓ **NOTE:** It may be necessary for a time period to elapse so that the concrete will harden enough to refloat and edge.

3. Refloat the surface of the curb.
4. Use a curb edger to edge the inside edge of the curb.
5. Use a sidewalk edger to edge the outside edge of the curb.
6. To edge, tilt the front of the edger slightly up and move it forward in an arm's length pattern.

✓ **NOTE:** To avoid picking up the surface of the concrete, lift the edger only while it is still in motion.

7. Extend the edger at arm's length and draw backward with the rear of the edger tilted up slightly.



**Yes No**

- 8. Continue this procedure until both edges of the curbs have been rounded and smoothed.
- 9. Use a margin trowel or a small trowel to trowel the top surface of the curb and to work out the edger marks.
- 10. Use a claw hammer to remove all the cleats when the concrete is hard enough.
- 11. Re-edge both sides of the curb using the same process as in steps 6 through 8.
- 12. Remove the forms with a hammer and finish the face of the curb.
- 13. Finish the face of the curb closing up holes and leaving the curb face relatively smooth.
- 14. Use a small trowel or a margin trowel to trowel the face of the curb.
- 15. Use a fine-haired brush tilted slightly and draw it over the face and front of the curb in a lengthwise motion until the curb is finished.
- 16. Follow the same procedure to finish the other side of the curb if necessary.
- 17. Apply a curing agent using a sprayer with the nozzle adjusted to a fine mist.
- 18. Use a margin trowel, brush, and water to clean the tools and equipment.
- 19. Have the instructor check your work.
- 20. Clean the work area and return tools and equipment to proper storage.



---

## SKILL TEST RECORD

### PRODUCT EVALUATION

**Evaluator note:** Rate the student on the following criteria by circling the appropriate numbers. Each criterion must receive a rating of “3” or higher to demonstrate student mastery. (See Key below.) A student who is unable to demonstrate mastery should review the material and submit another product for evaluation.

Criteria:

Safety	4	3	2	1
Use of tools	4	3	2	1
General appearance	4	3	2	1
Overall performance	4	3	2	1

### AVERAGE RATING

**Evaluator note:** To obtain an average rating for the Profile of Training Mastery, total the points in Product Evaluation and divide by the total number of criteria. Circle the rating on the Key.

### KEY

- 4 Skilled** — Can perform job with no additional training
- 3 Moderately Skilled** — Has performed job during training program; limited additional training may be required
- 2 Limited Skill** — Has performed job during training program; additional training is required to develop skill
- 1 Unskilled** — Is familiar with process, but is unable to perform job

### EVALUATOR'S COMMENTS

---

---

---



Name \_\_\_\_\_ Score \_\_\_\_\_

**OBJECTIVE 13**

**Place and finish concrete for a roll-type curb and gutter.**

**WORDS YOU SHOULD KNOW**

**mule**

template used to shape the profile of a curb and gutter

**BASIC SKILLS**



Employability

**EQUIPMENT  
AND SUPPLIES**

- Straightedge
- Hand floats
- Trowels
- Brush
- Margin trowel
- Edger with ½" radius
- Broom
- Sprayer
- Concrete
- Curing agent
- Mule or jig
- Personal protective equipment

✓ **NOTE:** Refer to C.F.R 1926.28 Sub Part C in regard to personal protective equipment.



## PROCEDURE

Yes No

1. Place the concrete at the starting point. (Figure 1)

FIGURE 1

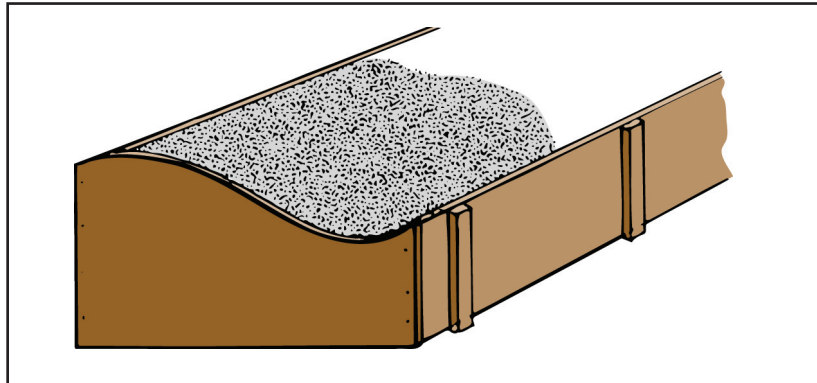

2. Use a mule to rod the concrete. (Figure 2)

✓ **NOTE:** For this type of curb and gutter, the concrete must be very low slump. Be sure to fully consolidate the concrete.

FIGURE 2

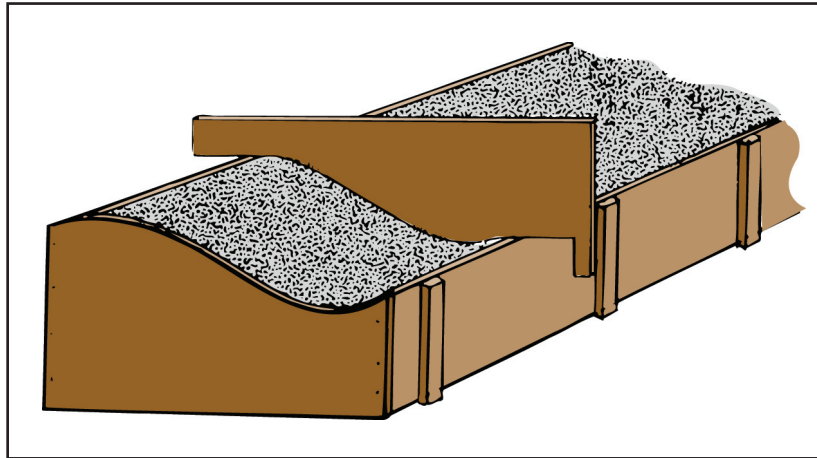

3. Continue placing and rodding until the entire curb is placed.



**Yes No**

4. Go back to the start of the placement and use a straightedge lengthwise to reach across the curb; work the straightedge from the gutter up and over the curb or use a mule to shape the curb and gutter. (Figure 3)

✓ **NOTE:** This will help to close up the concrete and leave the curb and gutter relatively smooth.

FIGURE 3

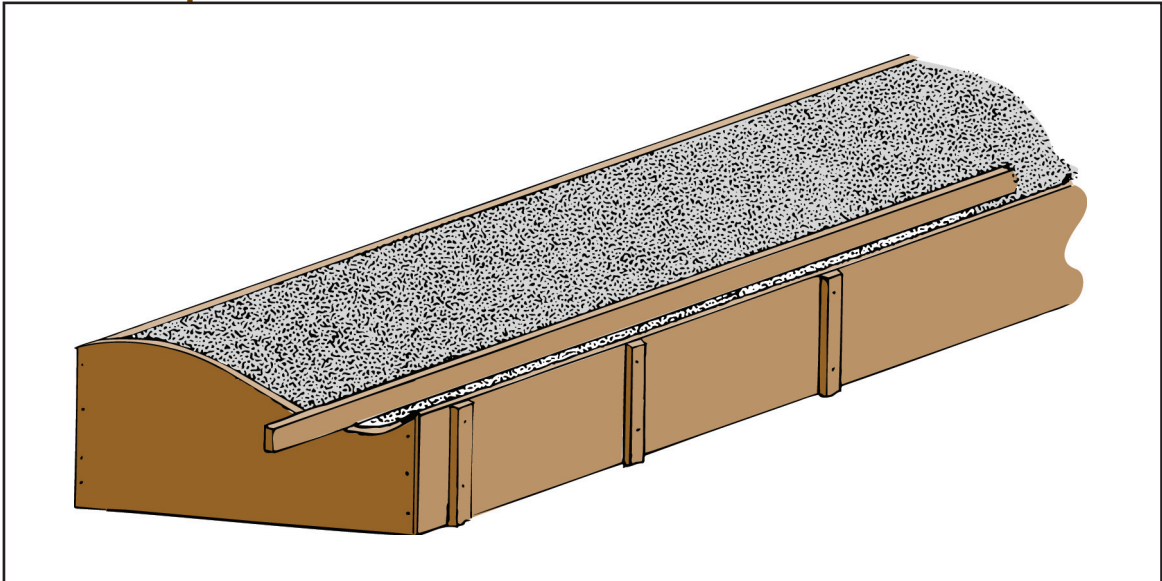

5. Continue this procedure until the entire curb and gutter has been straightened.
6. Use a hand float lengthwise with the curb and fairly flat to the surface; move in a sawlike motion to close up the curb, leaving it smooth. (Figure 4)

✓ **NOTE:** In some areas, finishers will also trowel the curb and gutter before brooming.



FIGURE 4

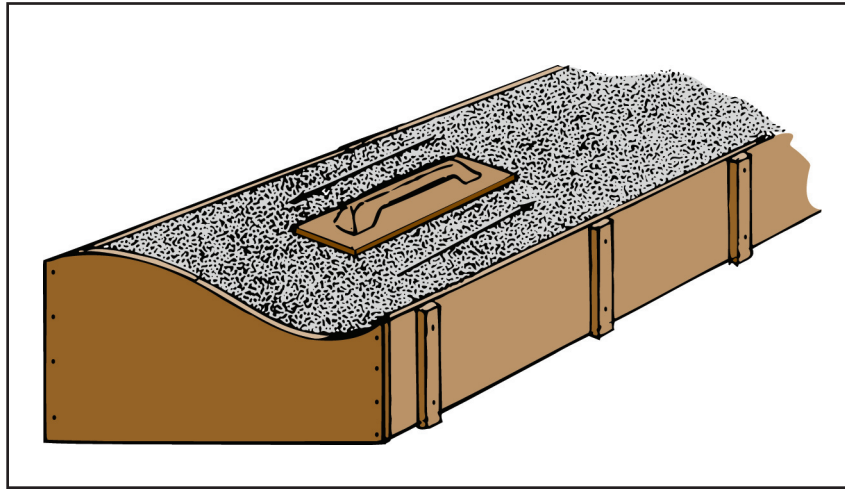

**Yes No**

7. Use an edger to edge the inside of all forms, expansion joints, and division plates.
- ✓ **NOTE:** This step is done after the curbs and gutters have been laid down.
- A. To edge, tilt the front of the edger slightly up and move forward in an arm's length pattern.
- ✓ **NOTE:** To avoid picking up the surface of the concrete lift the edger only while it is still in motion.
- B. Extend the edger at arm's length and draw backward with the rear edge of the edger slightly tilted up.
- ✓ **NOTE:** To avoid low places, do not put too much pressure on the edger.
8. Pull the plates up and out of the concrete after the division plates have been edged and as soon as the concrete is hard enough.
- ✓ **NOTE:** Do not wait too long before removing the division plates.



**Yes No**

- 9. Float out all of the edger marks.
- 10. Use a brush or a broom to finish the curb and gutter.
  - A. Draw the brush or broom across the gutter and up and over the curb.
  - B. Continue this procedure, overlapping the previous pass with each succeeding pass until entire the curb and gutter has been finished. (Figure 5)

**FIGURE 5**

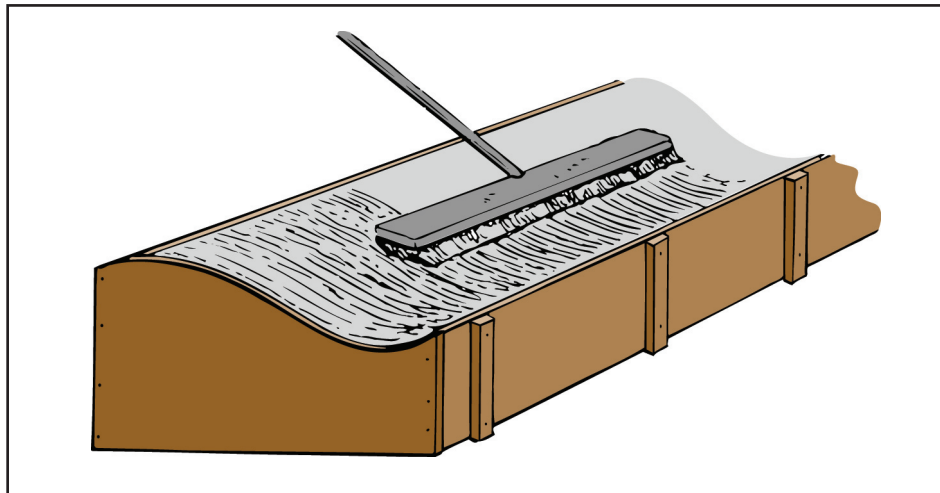

- 11. Apply a curing agent as soon as possible without damaging the finish.
- 12. Use a margin trowel, brush, and water to clean the tools and equipment.
- 13. Have the instructor check your work.
- 14. Clean the work area and return tools and equipment to proper storage.



---

## SKILL TEST RECORD

### PRODUCT EVALUATION

**Evaluator note:** Rate the student on the following criteria by circling the appropriate numbers. Each criterion must receive a rating of “3” or higher to demonstrate student mastery. (See Key below.) A student who is unable to demonstrate mastery should review the material and submit another product for evaluation.

Criteria:

Safety	4	3	2	1
Use of tools	4	3	2	1
General appearance	4	3	2	1
Overall performance	4	3	2	1

### AVERAGE RATING

**Evaluator note:** To obtain an average rating for the Profile of Training Mastery, total the points in Product Evaluation and divide by the total number of criteria. Circle the rating on the Key.

### KEY

- 4 Skilled** — Can perform job with no additional training
- 3 Moderately Skilled** — Has performed job during training program; limited additional training may be required
- 2 Limited Skill** — Has performed job during training program; additional training is required to develop skill
- 1 Unskilled** — Is familiar with process, but is unable to perform job

### EVALUATOR'S COMMENTS

---

---

---

