

INTRODUCTION

Large concrete slabs often require multiple pours to complete. This requires the construction of bulkheads to contain the fresh concrete in each section and the construction of screeds to ensure the proper grade is maintained across the width of the pour. In addition to being strong enough to contain the fresh concrete, bulkheads must also be built to grade. There are a number of different types of screed systems that you will find on a job site. In this unit you'll use wet screeds, adjustable screed chairs, pins and saddles, and learn to set grade stakes using different methods.

**FOCUS
ASSIGNMENTS**

FOCUS ASSIGNMENTS

1. Visit a construction site where large slabs are being poured.
2. Write a short description of how screeds and bulkheads were being used.



Writing



Employability

**UNIT
OBJECTIVE**

After completing this unit, you will show the following competencies by mastering the activities on the Assignment and Job Sheets and by scoring at least 85% on the Written Test.

**SPECIFIC
OBJECTIVES**

1. Distinguish between screeds and bulkheads according to their characteristics.
2. Identify types of screeds.
3. Determine spacing of screeds.
4. Determine spacing of screeds. (Assignment Sheet)
5. Set bulkheads for a four-inch slab. (Job Sheet 1)
6. Set wet pads using a builder's level or laser level. (Job Sheet 2)



7. Set pipe screeds using a builder's level or laser level. (Job Sheet 3)
8. Set grade stakes using a builder's level or laser level. (Job Sheet 4)
9. Set grade stakes using a hand level, a straightedge, and stringline. (Job Sheet 5)
10. Set adjustable screed chairs using a builder's level or laser level. (Job Sheet 6)
11. Set pins and saddles with a builder's or laser level and stringline. (Job Sheet 7)



OBJECTIVE 1

Distinguish between screeds and bulkheads according to their characteristics.

Optional Activities/
Resources in Instructor's
Guide

WORDS YOU SHOULD KNOW

screed	temporary guide used to support the straightedge when rodding concrete to an established grade
bulkhead	form used to cut off the concrete pour and to contain the concrete
leveling concrete	may also be referred to as dragging off, screeding, rodding, or straight edging
line	string used as a guide in setting forms and grades

- **Screed** (Figure 1)
 - ❑ Set to grade as a temporary guide for rodding (dragging off) concrete to an established grade
 - ❑ Removed after concrete is placed
 - ❑ Usually set no more than twelve feet apart

FIGURE 1

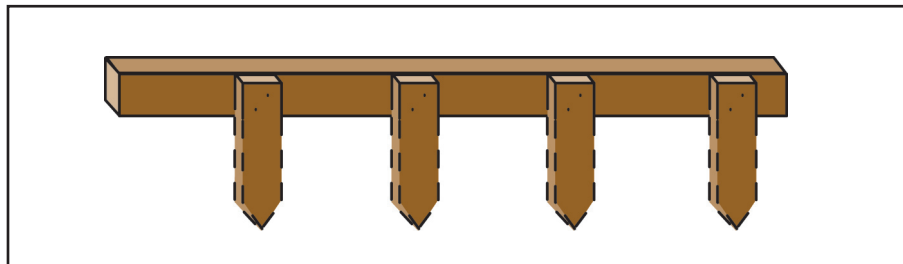

- **Bulkhead** (Figure 2)
 - ❑ Used to contain concrete and to cut off a concrete pour
 - ❑ Can be used as a guide for rodding (dragging off) concrete to established grade
 - ❑ Removed after concrete has set



FIGURE 2

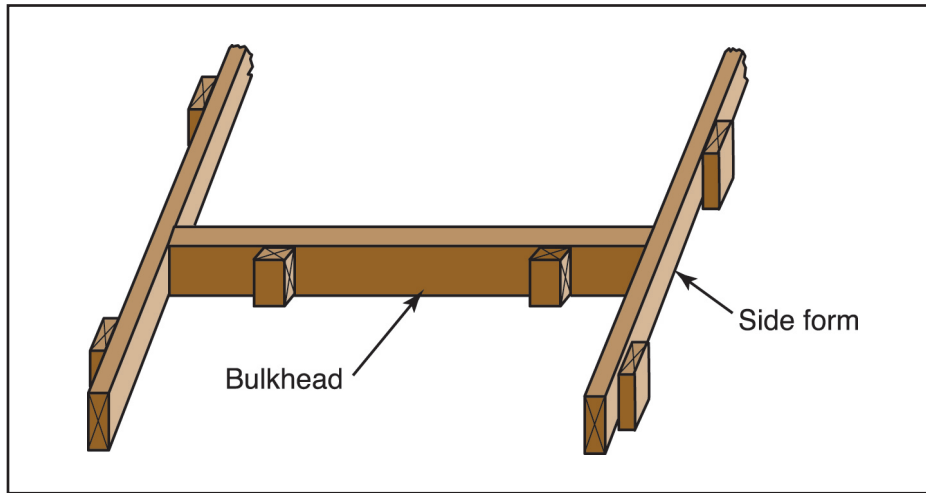

OBJECTIVE 2

Optional Activities/
Resources in Instructor's
Guide

Identify types of screeds.

WORDS YOU SHOULD KNOW

**wet pad
(wet screed)**

pad of fresh concrete with the top smoothed to grade; used as a screed

pipe screed

pipe set on stakes that have been leveled to proper grade; used as guide for rodding (dragging off) concrete

**adjustable
screed chair**

manufactured support that screws up and down and is used to hold screeds

✓ **NOTE:** Outside forms and bulkheads are also often used for screeds.

- Wood screed with wood stakes (Figure 3)

FIGURE 3

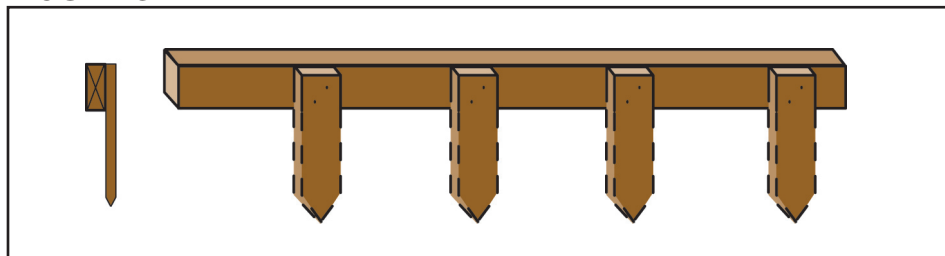

- Wood screed with metal stakes (Figure 4)

FIGURE 4

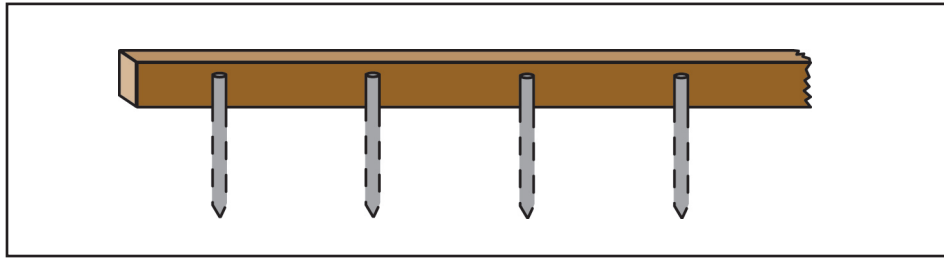

- Pipe screed with wood stakes (Figure 5)

FIGURE 5

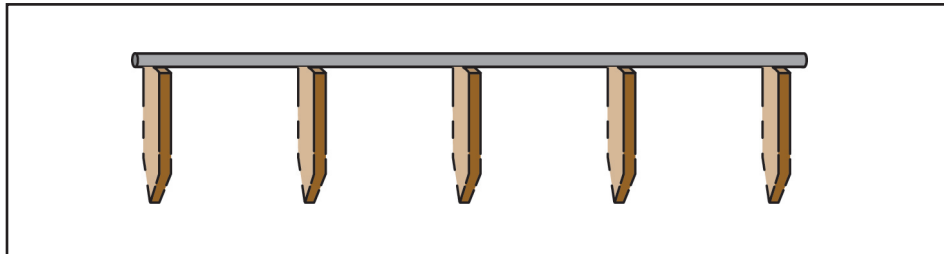

- Steel bar with adjustable saddle (Figure 6)

FIGURE 6

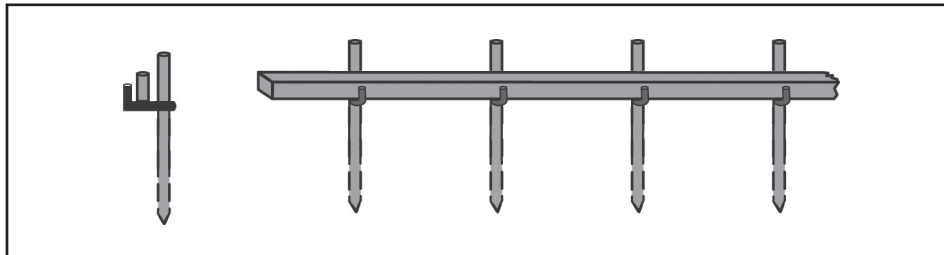

- Steel channel with wood stakes (Figure 7)

FIGURE 7

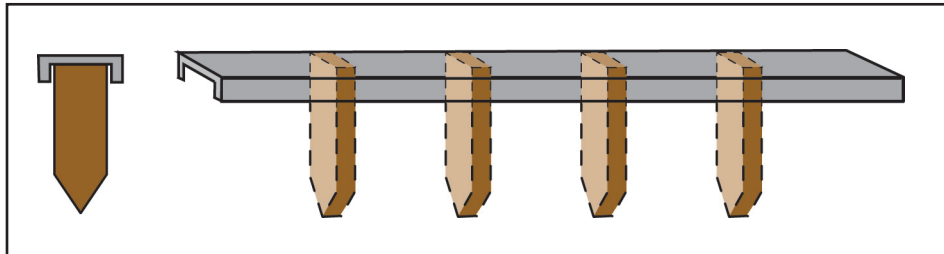

- Pipe screed with adjustable screed chairs (Figure 8)

FIGURE 8

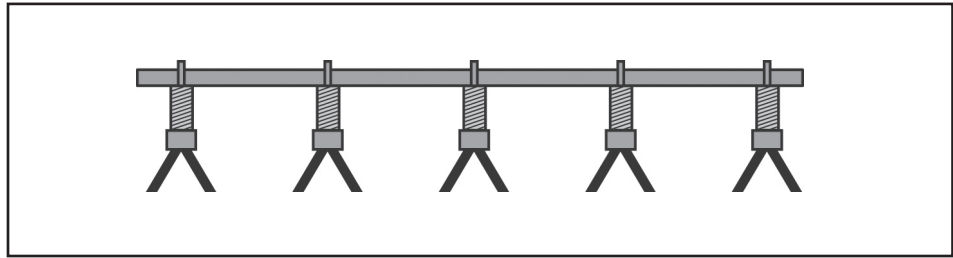

- Wet pads (wet screeds) (Figure 9)

FIGURE 9

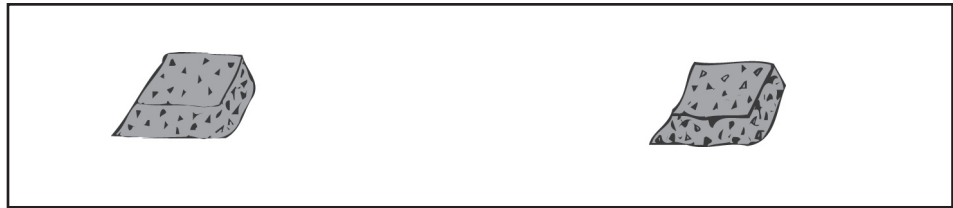

OBJECTIVE 3

Optional Activities/
Resources in Instructor's
Guide

Determine spacing of screeds.

WORDS YOU SHOULD KNOW

bay	area poured between screeds
cold joint	a joint in a concrete floor where the fresh concrete has bonded imperfectly or not at all to the previously placed concrete because too much time has elapsed between placements

✓ **NOTE:** Spacing of screeds is determined by the width of the area to be covered with concrete and the length of the straightedge that will be used for dragging off.

1. Determine approximate number of times length of straightedge will go into width of the area to be divided by screeds.

✓ **NOTE:** Always round up to allow overlap of straightedge when leveling concrete. Always layout larger slabs to shortest bay length to eliminate cold joints.



2. Divide area into the number of equal parts from Step 1.

EXAMPLE: When using a twelve-foot straightedge and pouring from the left, place the screed as shown below. (Figure 10)

FIGURE 10

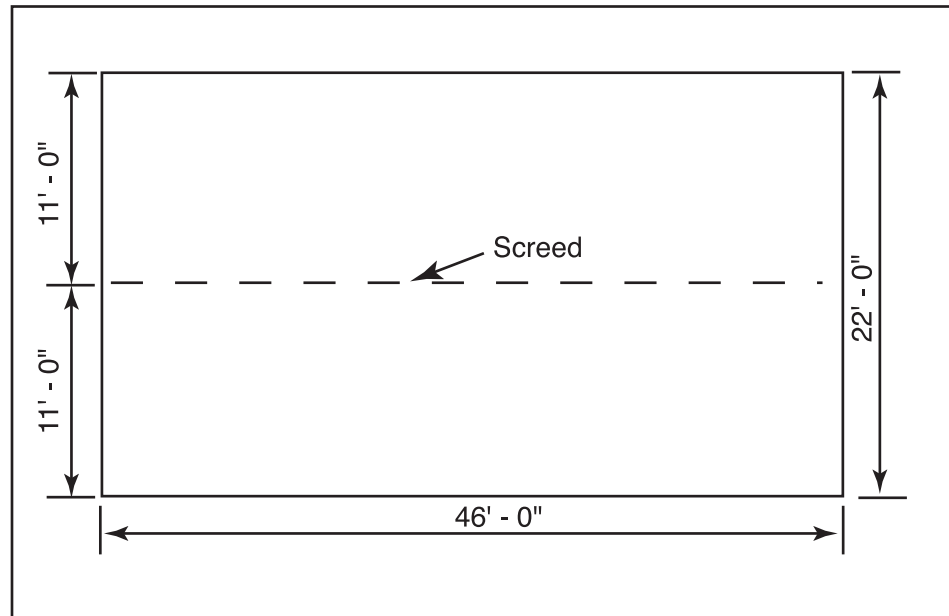

EXAMPLE: When using a twelve-foot straightedge and pouring from the left, place the screeds as shown below. (Figure 11)

FIGURE 11

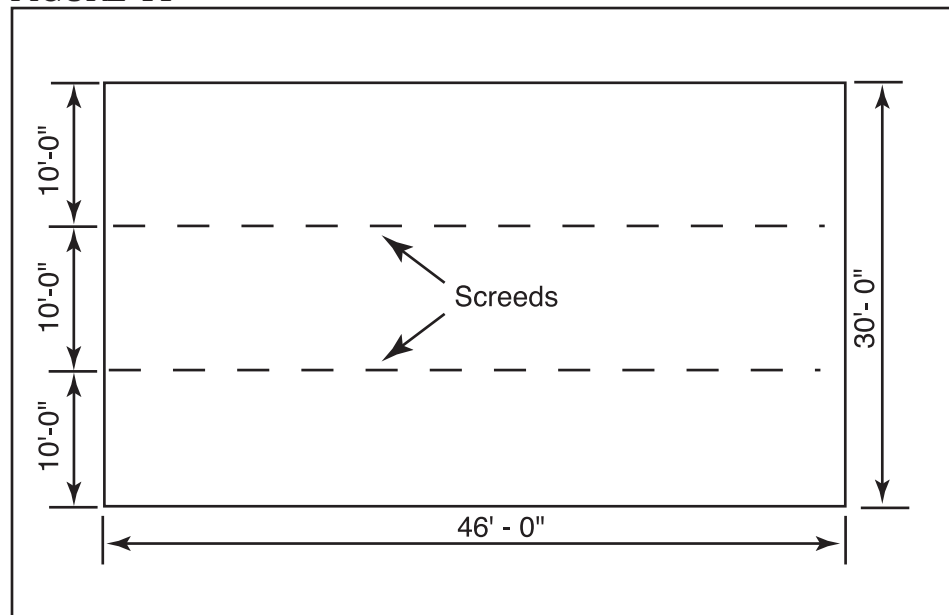

- OBJECTIVE 4** **Complete the Assignment Sheet.**
- OBJECTIVE 5** **Complete Job Sheet 1.**
- OBJECTIVE 6** **Complete Job Sheet 2.**
- OBJECTIVE 7** **Complete Job Sheet 3.**
- OBJECTIVE 8** **Complete Job Sheet 4.**
- OBJECTIVE 9** **Complete Job Sheet 5.**
- OBJECTIVE 10** **Complete Job Sheet 6.**
- OBJECTIVE 11** **Complete Job Sheet 7.**



Name _____ Score _____

OBJECTIVE 4

Determine spacing of screeds.

BASIC SKILLS



Employability

EQUIPMENT AND SUPPLIES

- Pencil and paper

INSTRUCTIONS

Determine the placement of screeds for the following areas. In both cases, a twelve-foot straightedge will be used, the pour will start on the right and the concrete supply will be on the left. Draw lines to mark the approximate screed placement on each drawing and write the correct measurement for spacing in the blank below the drawing.

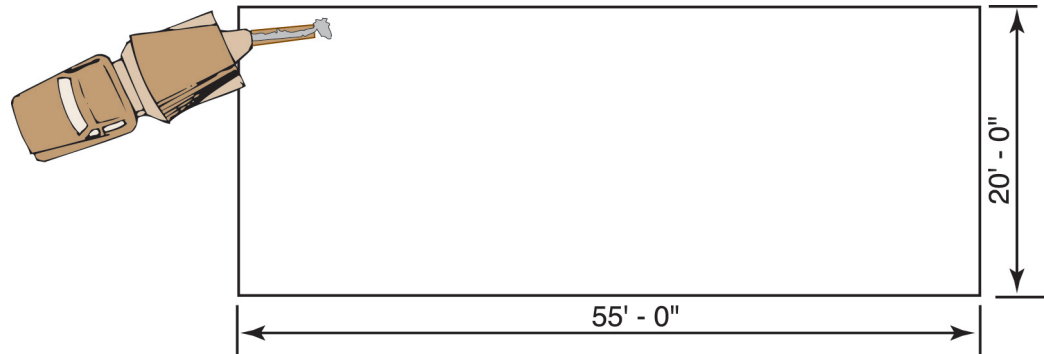

Measurement _____



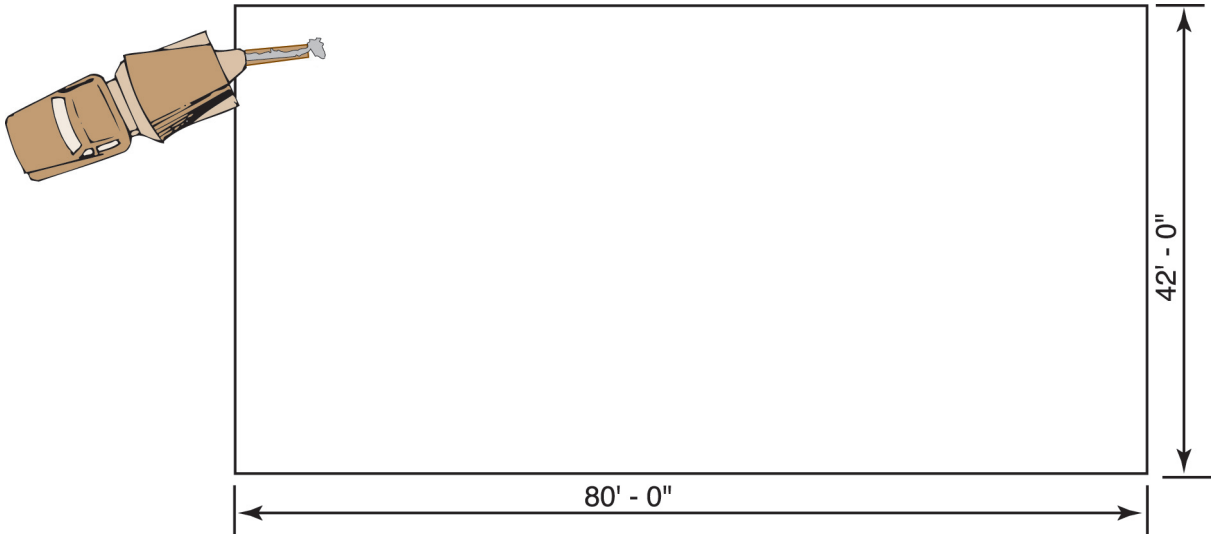

Measurement _____



Name _____ Score _____

OBJECTIVE 5

Set bulkheads for a four-inch slab.

WORDS YOU SHOULD KNOW

builder's level instrument consisting of a telescope, leveling bubble, and tripod; used primarily to establish grade levels

laser level a level that transmits a rotating beam to a receiver to establish grade level

BASIC SKILLS



Employability

EQUIPMENT AND SUPPLIES

- Sledge hammer
- Claw hammer
- Hand saw
- Line
- Builder's level or laser level and rod
- Folding rule or steel tape
- 100-foot tape
- Sixteen 2" x 4" x 12' form boards
- Seventy stakes
- 8d and 16d duplex nails
- Pencil
- Personal protective equipment

✓ **NOTE:** Refer to C.F.R. 1926.28 Sub Part C in regard to personal protective equipment.



PROCEDURE

Yes No

1. Establish the location of the bulkhead. (Figure 1)

FIGURE 1

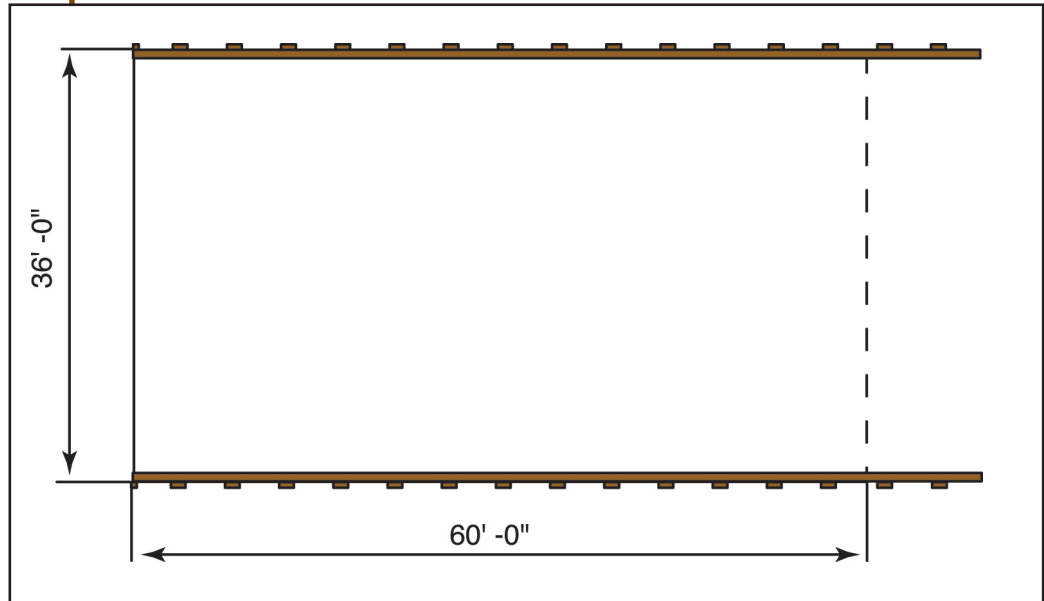

2. Ensure that the grade is correct.
3. Use the 3-4-5 method to square the bulkhead using first form (10 feet long or longer). (Figure 2)

FIGURE 2

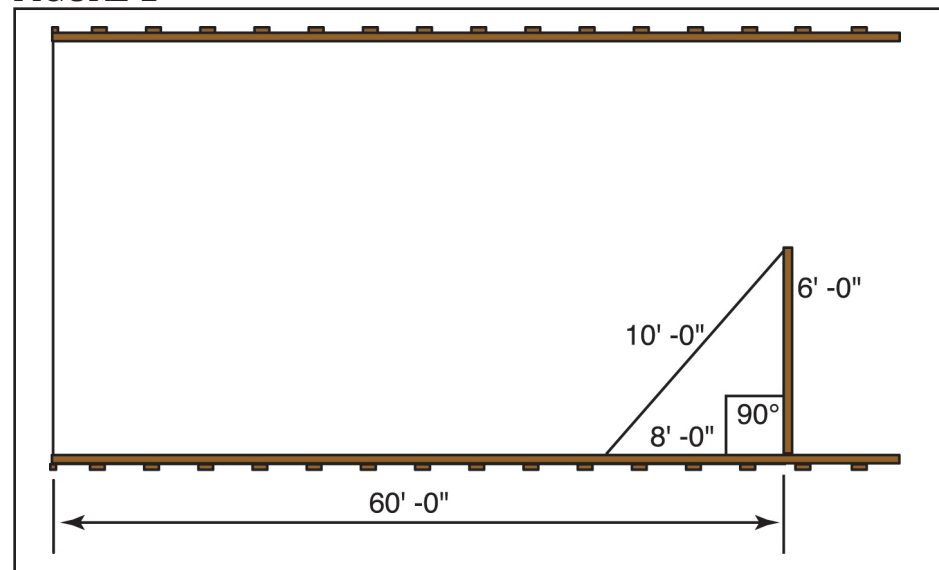

Yes No

4. Secure the line to the formed corner to the established grade and stretch line tight to the established grade on opposite corner using the 3-4-5 form as a reference. (Figure 3)

FIGURE 3

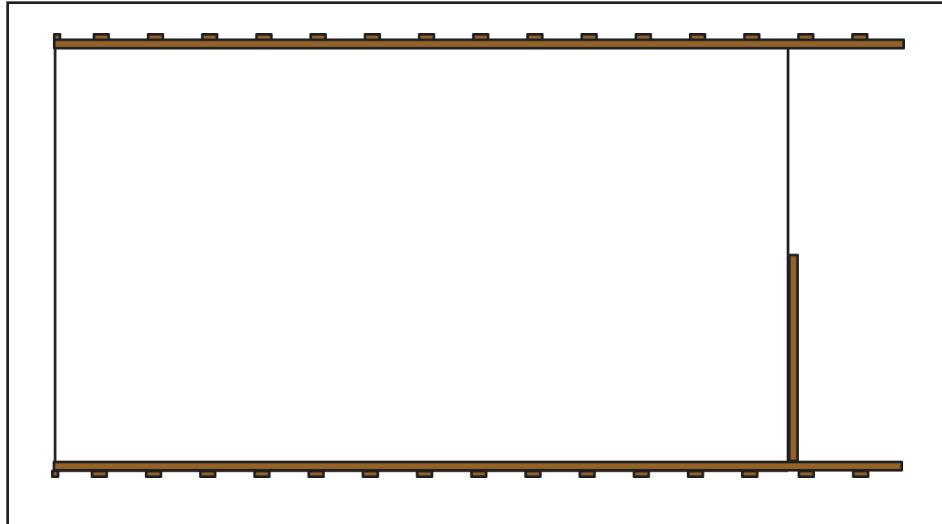

5. Drive all stakes on the outside of the form, using the line on the edge of the concrete side of the form as a guide to keep them straight and to grade (Figure 4), nailing stakes to bulkhead.

FIGURE 4

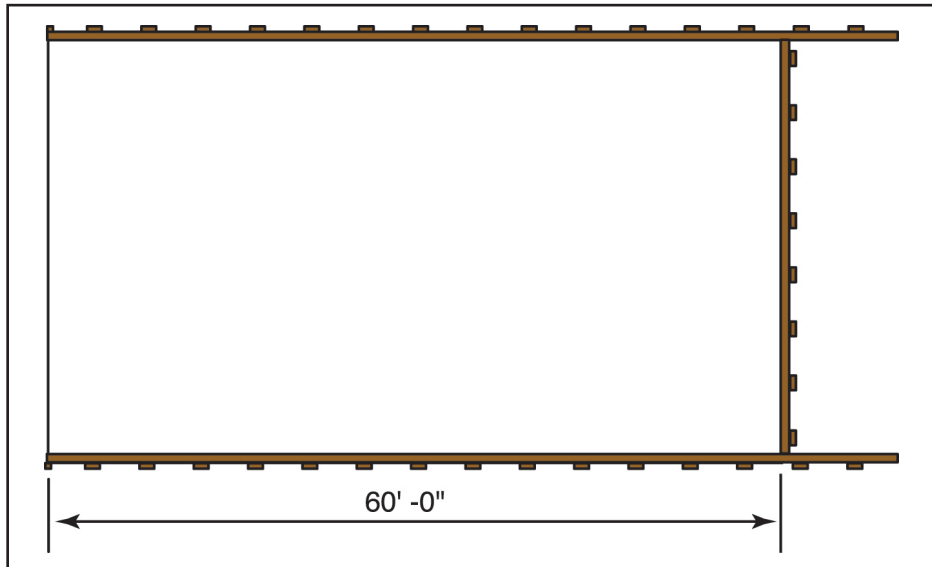

✓ **NOTE:** Be careful not to touch the line with the forms.



Yes No

- 6. Follow the same procedure to erect the bulkhead on the opposite end.
- 7. Have the instructor check your work.
- 8. Clean the work area and return tools and equipment to proper storage.



SKILL TEST RECORD

PRODUCT EVALUATION

Evaluator note: Rate the student on the following criteria by circling the appropriate numbers. Each criterion must receive a rating of “3” or higher to demonstrate student mastery. (See Key below.) A student who is unable to demonstrate mastery should review the material and submit another product for evaluation.

Criteria:

Safety	4	3	2	1
Used level correctly	4	3	2	1
Formwork	4	3	2	1
Squared project correctly	4	3	2	1
Overall performance	4	3	2	1

AVERAGE RATING

Evaluator note: To obtain an average rating for the Profile of Training Mastery, total the points in Product Evaluation and divide by the total number of criteria. Circle the rating on the Key.

KEY

- 4 Skilled** — Can perform job with no additional training
- 3 Moderately Skilled** — Has performed job during training program; limited additional training may be required
- 2 Limited Skill** — Has performed job during training program; additional training is required to develop skill
- 1 Unskilled** — Is familiar with process, but is unable to perform job

EVALUATOR'S COMMENTS





Name _____ Score _____

OBJECTIVE 6

Set wet pads using a builder's level or laser level.

BASIC SKILLS



Employability

**EQUIPMENT
AND SUPPLIES**

- Shovel
- Hand float
- Builder's level or laser level
- Concrete
- Personal protective equipment

✓ **NOTE:** Refer to C.F.R. 1926.28 Sub Part C in regard to personal protective equipment.

PROCEDURE

Yes No

1. Establish the location of the screed.
2. Use a shovel to place a pile of concrete at the established screed location (Point 1).
3. Set up the level and establish the grade.
4. Place the leveling rod on the concrete and shoot the finish grade at the top of the concrete pad (Point 2).
5. Float the pile of concrete to the established grade.
6. Mark the wet screed with an "X" to distinguish the grade for rodding purposes. This establishes the elevation for the finished floor height.



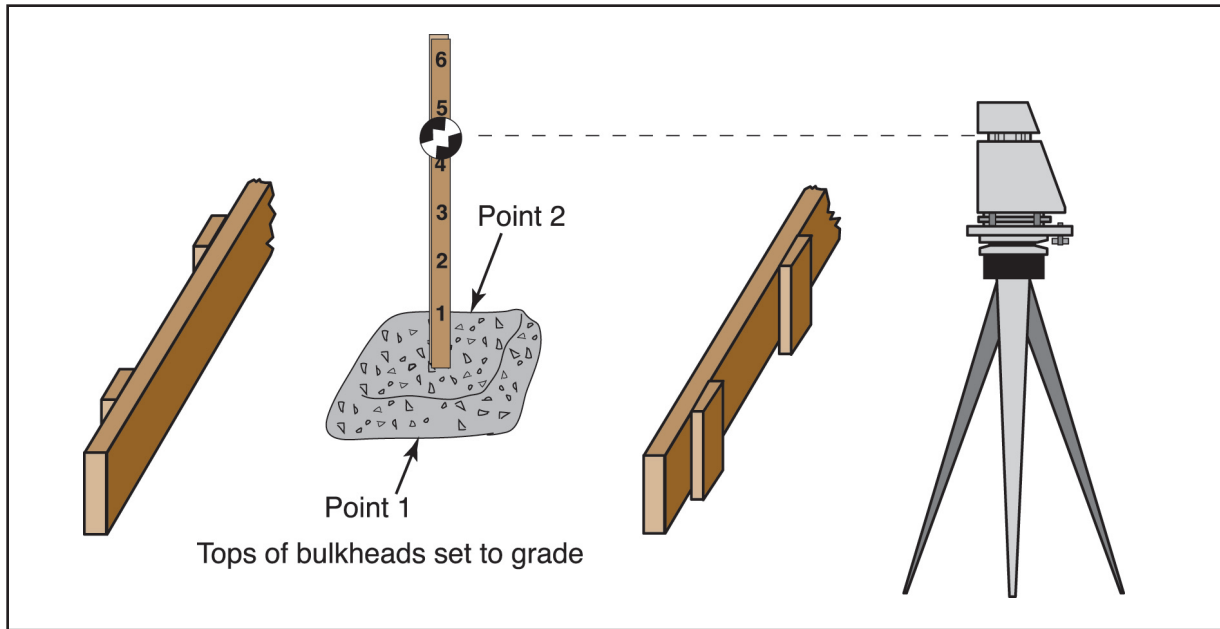

Yes No

- 7. Have the instructor check your work.
- 8. Clean the work area and return tools and equipment to proper storage.



SKILL TEST RECORD

PRODUCT EVALUATION

Evaluator note: Rate the student on the following criteria by circling the appropriate numbers. Each criterion must receive a rating of “3” or higher to demonstrate student mastery. (See Key below.) A student who is unable to demonstrate mastery should review the material and submit another product for evaluation.

Criteria:

Safety	4	3	2	1
Used level correctly	4	3	2	1
Overall performance	4	3	2	1

AVERAGE RATING

Evaluator note: To obtain an average rating for the Profile of Training Mastery, total the points in Product Evaluation and divide by the total number of criteria. Circle the rating on the Key.

KEY

- 4 Skilled** — Can perform job with no additional training
- 3 Moderately Skilled** — Has performed job during training program; limited additional training may be required
- 2 Limited Skill** — Has performed job during training program; additional training is required to develop skill
- 1 Unskilled** — Is familiar with process, but is unable to perform job

EVALUATOR'S COMMENTS



INTRODUCTION

Large concrete slabs often require multiple pours to complete. This requires the construction of bulkheads to contain the fresh concrete in each section and the construction of screeds to ensure the proper grade is maintained across the width of the pour. In addition to being strong enough to contain the fresh concrete, bulkheads must also be built to grade. There are a number of different types of screed systems that you will find on a job site. In this unit you'll use wet screeds, adjustable screed chairs, pins and saddles, and learn to set grade stakes using different methods.

FOCUS
ASSIGNMENTS

FOCUS ASSIGNMENTS

1. Visit a construction site where large slabs are being poured.
2. Write a short description of how screeds and bulkheads were being used.



Writing



Employability

UNIT
OBJECTIVE

After completing this unit, you will show the following competencies by mastering the activities on the Assignment and Job Sheets and by scoring at least 85% on the Written Test.

SPECIFIC
OBJECTIVES

1. Distinguish between screeds and bulkheads according to their characteristics.
2. Identify types of screeds.
3. Determine spacing of screeds.
4. Determine spacing of screeds. (Assignment Sheet)
5. Set bulkheads for a four-inch slab. (Job Sheet 1)
6. Set wet pads using a builder's level or laser level. (Job Sheet 2)



7. Set pipe screeds using a builder's level or laser level. (Job Sheet 3)
8. Set grade stakes using a builder's level or laser level. (Job Sheet 4)
9. Set grade stakes using a hand level, a straightedge, and stringline. (Job Sheet 5)
10. Set adjustable screed chairs using a builder's level or laser level. (Job Sheet 6)
11. Set pins and saddles with a builder's or laser level and stringline. (Job Sheet 7)



OBJECTIVE 1

Distinguish between screeds and bulkheads according to their characteristics.

Optional Activities/
Resources in Instructor's
Guide

WORDS YOU SHOULD KNOW

screed	temporary guide used to support the straightedge when rodding concrete to an established grade
bulkhead	form used to cut off the concrete pour and to contain the concrete
leveling concrete	may also be referred to as dragging off, screeding, rodding, or straight edging
line	string used as a guide in setting forms and grades

- **Screed** (Figure 1)
 - ❑ Set to grade as a temporary guide for rodding (dragging off) concrete to an established grade
 - ❑ Removed after concrete is placed
 - ❑ Usually set no more than twelve feet apart

FIGURE 1

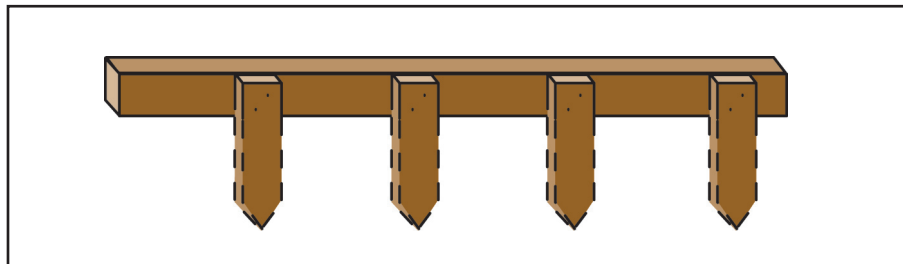

- **Bulkhead** (Figure 2)
 - ❑ Used to contain concrete and to cut off a concrete pour
 - ❑ Can be used as a guide for rodding (dragging off) concrete to established grade
 - ❑ Removed after concrete has set



FIGURE 2

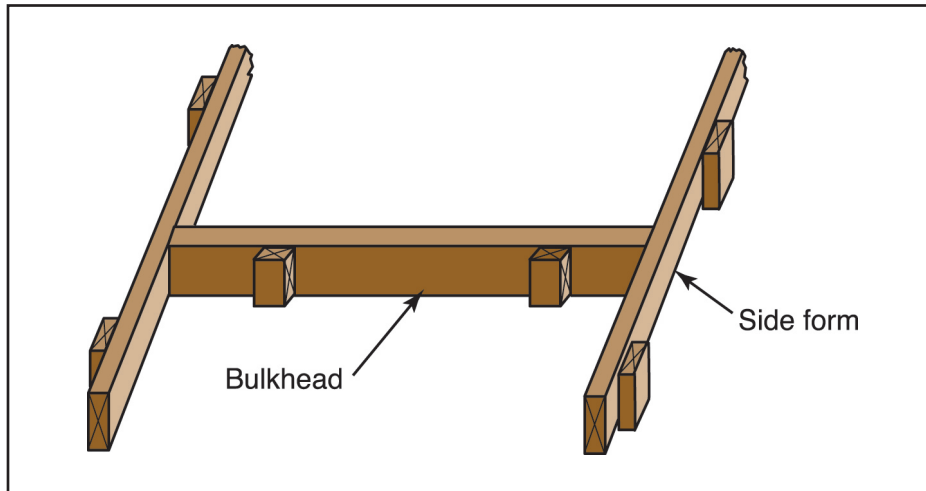

OBJECTIVE 2

Optional Activities/
Resources in Instructor's
Guide

Identify types of screeds.

WORDS YOU SHOULD KNOW

**wet pad
(wet screed)**

pad of fresh concrete with the top smoothed to grade; used as a screed

pipe screed

pipe set on stakes that have been leveled to proper grade; used as guide for rodding (dragging off) concrete

**adjustable
screed chair**

manufactured support that screws up and down and is used to hold screeds

✓ **NOTE:** Outside forms and bulkheads are also often used for screeds.

- Wood screed with wood stakes (Figure 3)

FIGURE 3

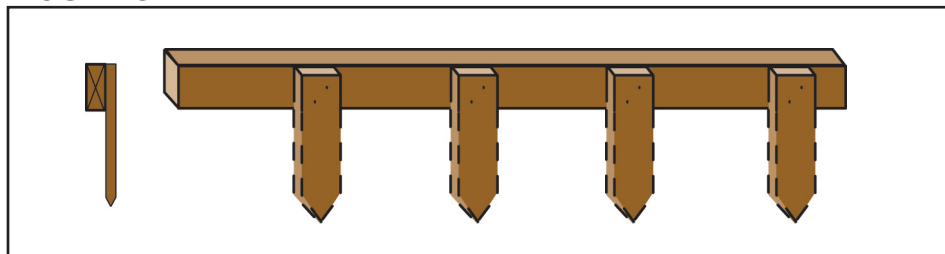

- Wood screed with metal stakes (Figure 4)

FIGURE 4

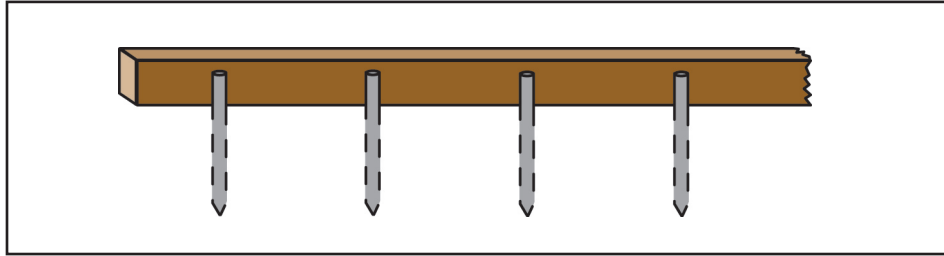

- Pipe screed with wood stakes (Figure 5)

FIGURE 5

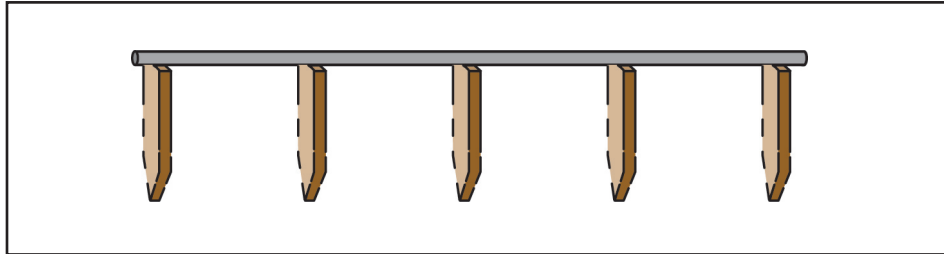

- Steel bar with adjustable saddle (Figure 6)

FIGURE 6

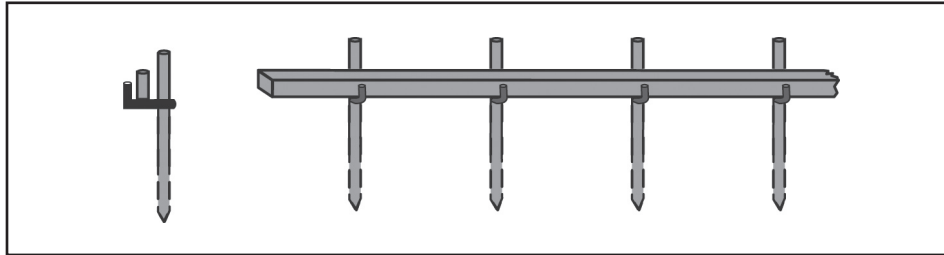

- Steel channel with wood stakes (Figure 7)

FIGURE 7

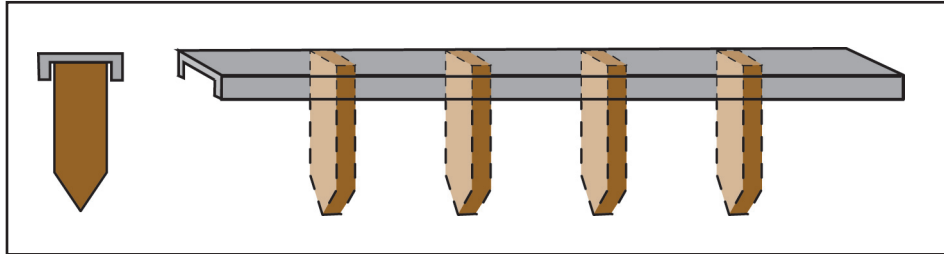

- Pipe screed with adjustable screed chairs (Figure 8)

FIGURE 8

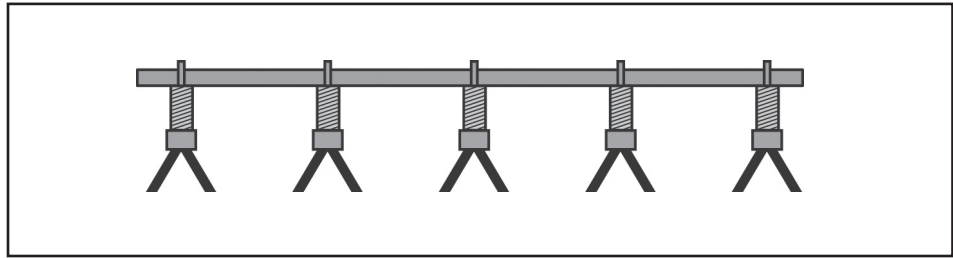

- Wet pads (wet screeds) (Figure 9)

FIGURE 9

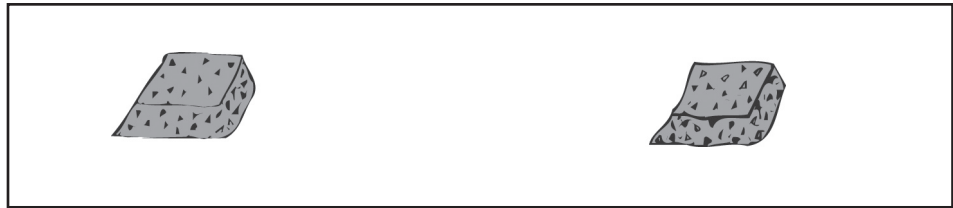

OBJECTIVE 3

Optional Activities/
Resources in Instructor's
Guide

Determine spacing of screeds.

WORDS YOU SHOULD KNOW

bay	area poured between screeds
cold joint	a joint in a concrete floor where the fresh concrete has bonded imperfectly or not at all to the previously placed concrete because too much time has elapsed between placements

✓ **NOTE:** Spacing of screeds is determined by the width of the area to be covered with concrete and the length of the straightedge that will be used for dragging off.

1. Determine approximate number of times length of straightedge will go into width of the area to be divided by screeds.

✓ **NOTE:** Always round up to allow overlap of straightedge when leveling concrete. Always layout larger slabs to shortest bay length to eliminate cold joints.



2. Divide area into the number of equal parts from Step 1.

EXAMPLE: When using a twelve-foot straightedge and pouring from the left, place the screed as shown below. (Figure 10)

FIGURE 10

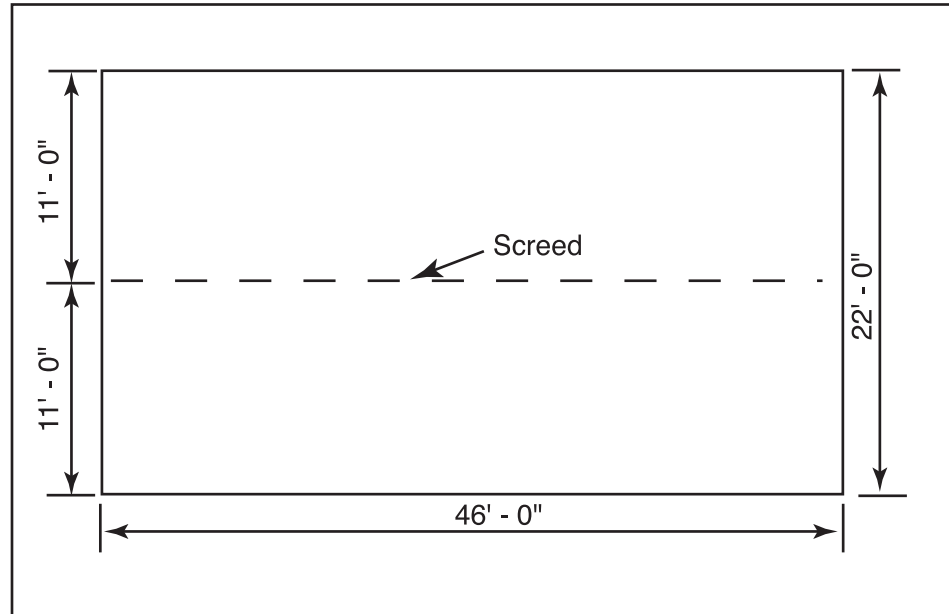

EXAMPLE: When using a twelve-foot straightedge and pouring from the left, place the screeds as shown below. (Figure 11)

FIGURE 11

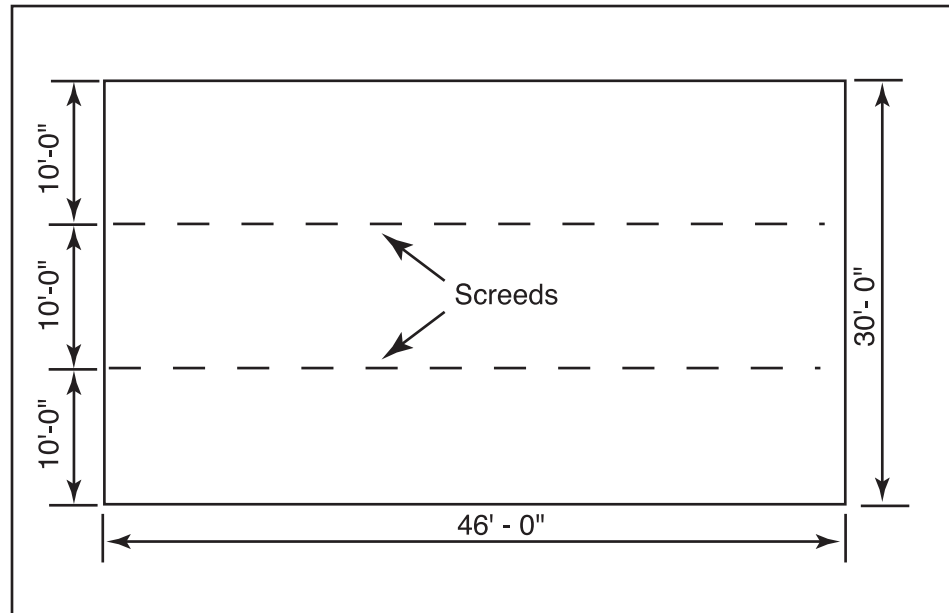

- OBJECTIVE 4** **Complete the Assignment Sheet.**
- OBJECTIVE 5** **Complete Job Sheet 1.**
- OBJECTIVE 6** **Complete Job Sheet 2.**
- OBJECTIVE 7** **Complete Job Sheet 3.**
- OBJECTIVE 8** **Complete Job Sheet 4.**
- OBJECTIVE 9** **Complete Job Sheet 5.**
- OBJECTIVE 10** **Complete Job Sheet 6.**
- OBJECTIVE 11** **Complete Job Sheet 7.**



Name _____ Score _____

OBJECTIVE 4

Determine spacing of screeds.

BASIC SKILLS



Employability

EQUIPMENT AND SUPPLIES

- Pencil and paper

INSTRUCTIONS

Determine the placement of screeds for the following areas. In both cases, a twelve-foot straightedge will be used, the pour will start on the right and the concrete supply will be on the left. Draw lines to mark the approximate screed placement on each drawing and write the correct measurement for spacing in the blank below the drawing.

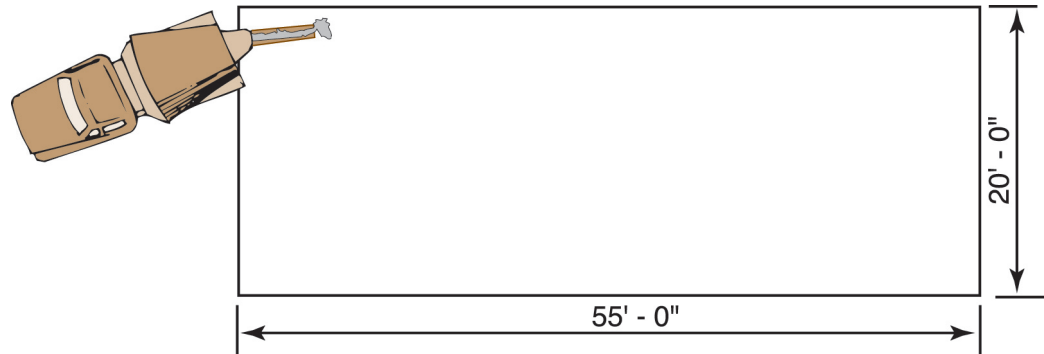

Measurement _____



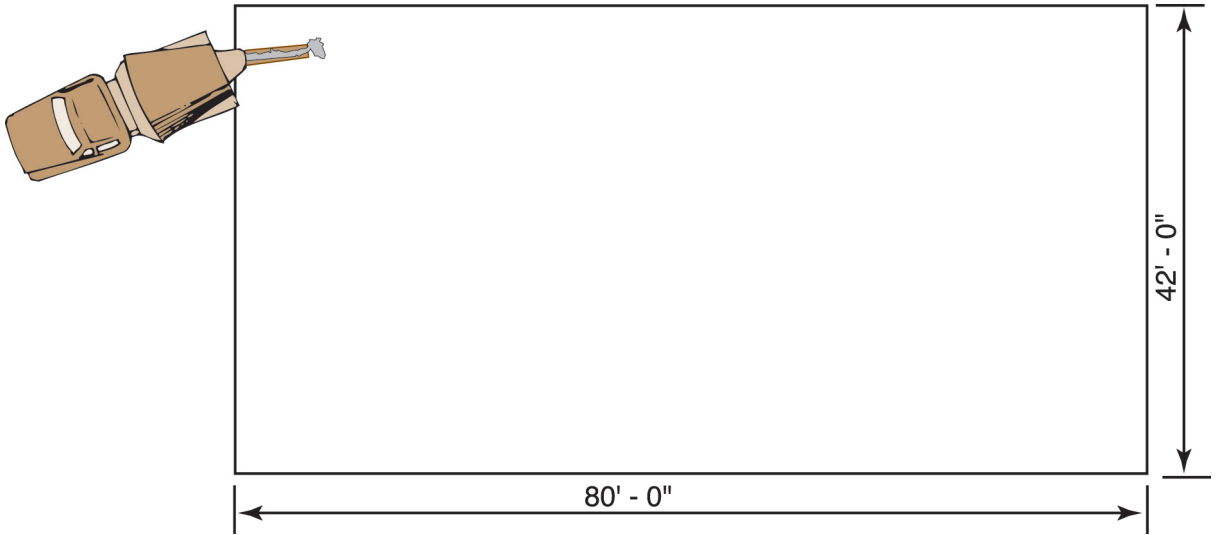

Measurement _____



Name _____ Score _____

OBJECTIVE 5

Set bulkheads for a four-inch slab.

WORDS YOU SHOULD KNOW

builder's level	instrument consisting of a telescope, leveling bubble, and tripod; used primarily to establish grade levels
laser level	a level that transmits a rotating beam to a receiver to establish grade level

BASIC SKILLS



Employability

EQUIPMENT AND SUPPLIES

- Sledge hammer
- Claw hammer
- Hand saw
- Line
- Builder's level or laser level and rod
- Folding rule or steel tape
- 100-foot tape
- Sixteen 2" x 4" x 12' form boards
- Seventy stakes
- 8d and 16d duplex nails
- Pencil
- Personal protective equipment

✓ **NOTE:** Refer to C.F.R. 1926.28 Sub Part C in regard to personal protective equipment.



PROCEDURE

Yes No

1. Establish the location of the bulkhead. (Figure 1)

FIGURE 1

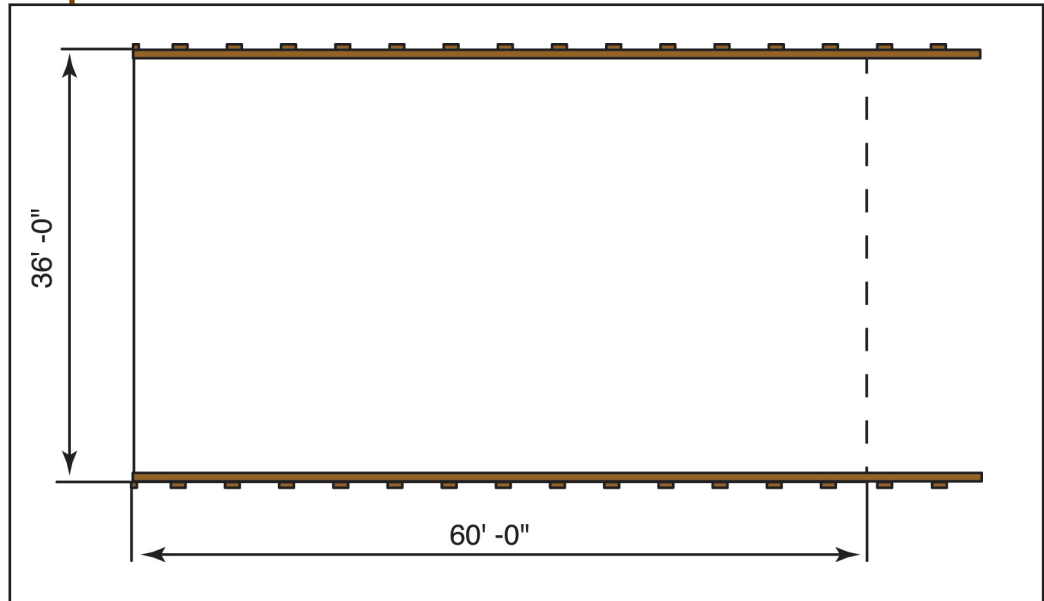

2. Ensure that the grade is correct.
3. Use the 3-4-5 method to square the bulkhead using first form (10 feet long or longer). (Figure 2)

FIGURE 2

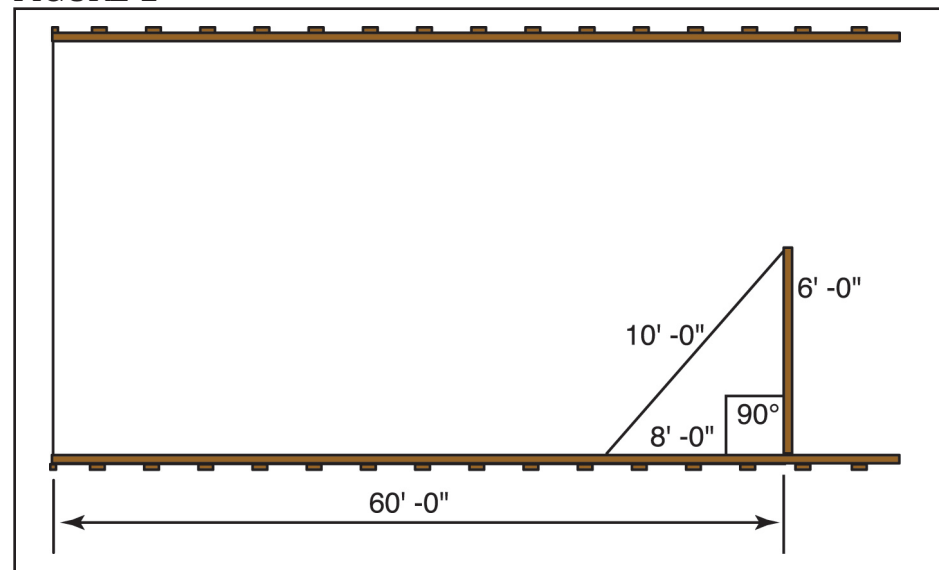

Yes No

4. Secure the line to the formed corner to the established grade and stretch line tight to the established grade on opposite corner using the 3-4-5 form as a reference. (Figure 3)

FIGURE 3

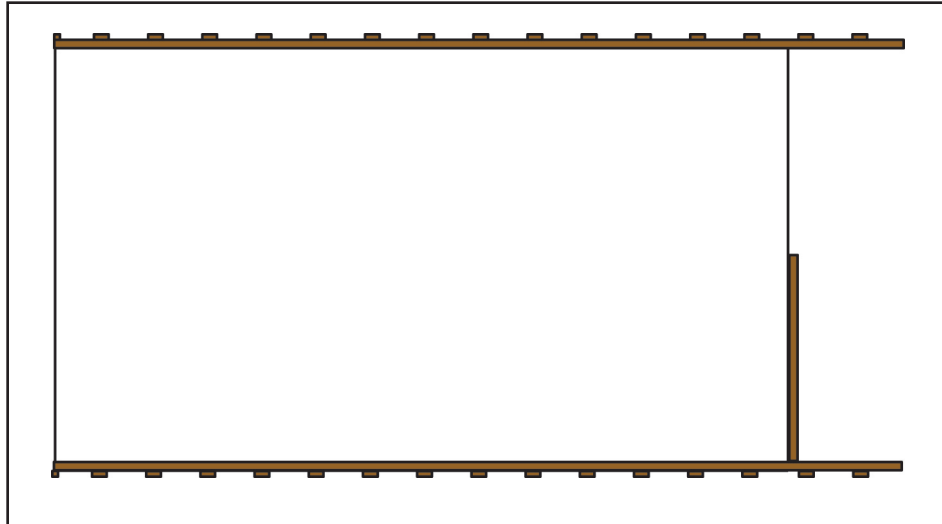

5. Drive all stakes on the outside of the form, using the line on the edge of the concrete side of the form as a guide to keep them straight and to grade (Figure 4), nailing stakes to bulkhead.

FIGURE 4

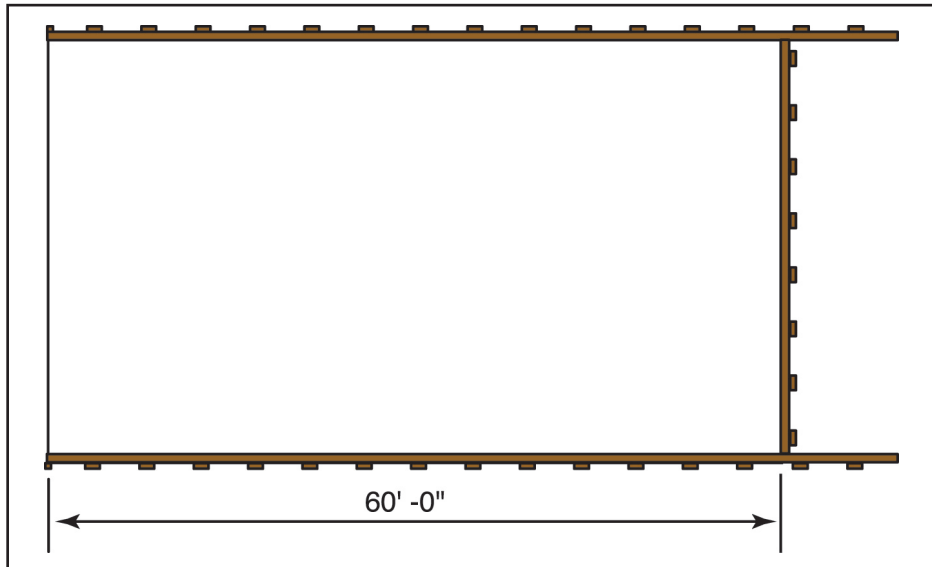

✓ **NOTE:** Be careful not to touch the line with the forms.



Yes No

- 6. Follow the same procedure to erect the bulkhead on the opposite end.
- 7. Have the instructor check your work.
- 8. Clean the work area and return tools and equipment to proper storage.



SKILL TEST RECORD

PRODUCT EVALUATION

Evaluator note: Rate the student on the following criteria by circling the appropriate numbers. Each criterion must receive a rating of “3” or higher to demonstrate student mastery. (See Key below.) A student who is unable to demonstrate mastery should review the material and submit another product for evaluation.

Criteria:

Safety	4	3	2	1
Used level correctly	4	3	2	1
Formwork	4	3	2	1
Squared project correctly	4	3	2	1
Overall performance	4	3	2	1

AVERAGE RATING

Evaluator note: To obtain an average rating for the Profile of Training Mastery, total the points in Product Evaluation and divide by the total number of criteria. Circle the rating on the Key.

KEY

- 4 Skilled** — Can perform job with no additional training
- 3 Moderately Skilled** — Has performed job during training program; limited additional training may be required
- 2 Limited Skill** — Has performed job during training program; additional training is required to develop skill
- 1 Unskilled** — Is familiar with process, but is unable to perform job

EVALUATOR'S COMMENTS





Name _____ Score _____

OBJECTIVE 6

Set wet pads using a builder's level or laser level.

BASIC SKILLS



Employability

**EQUIPMENT
AND SUPPLIES**

- Shovel
- Hand float
- Builder's level or laser level
- Concrete
- Personal protective equipment

✓ **NOTE:** Refer to C.F.R. 1926.28 Sub Part C in regard to personal protective equipment.

PROCEDURE

Yes No

1. Establish the location of the screed.
2. Use a shovel to place a pile of concrete at the established screed location (Point 1).
3. Set up the level and establish the grade.
4. Place the leveling rod on the concrete and shoot the finish grade at the top of the concrete pad (Point 2).
5. Float the pile of concrete to the established grade.
6. Mark the wet screed with an "X" to distinguish the grade for rodding purposes. This establishes the elevation for the finished floor height.



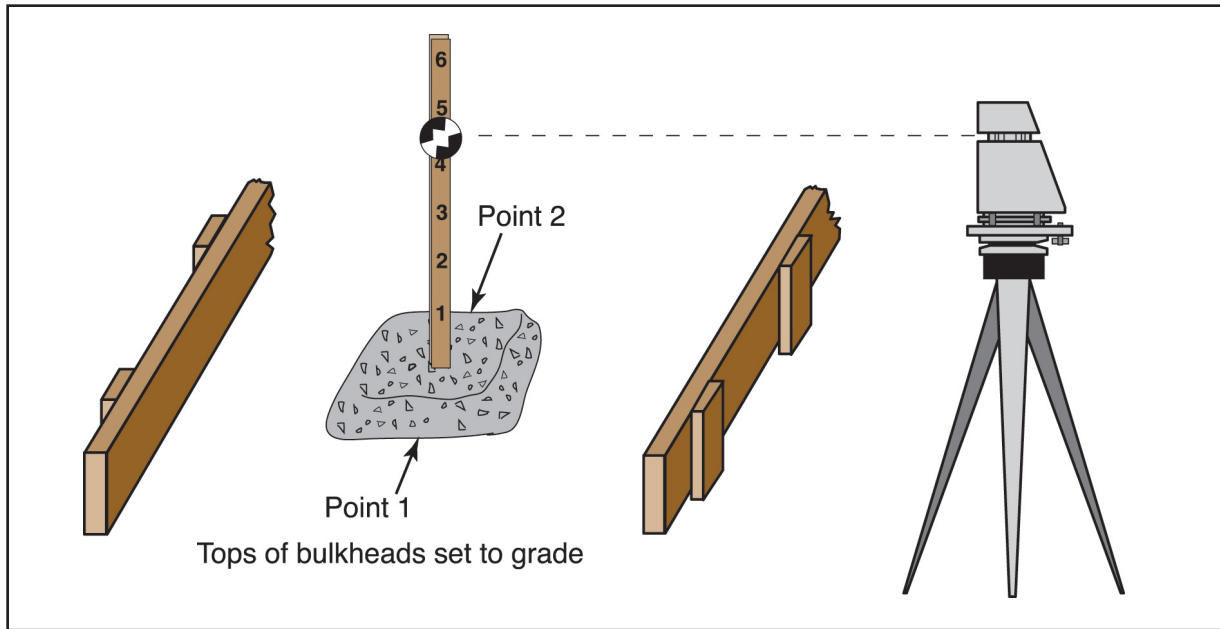

Yes No

- 7. Have the instructor check your work.
- 8. Clean the work area and return tools and equipment to proper storage.



SKILL TEST RECORD

PRODUCT EVALUATION

Evaluator note: Rate the student on the following criteria by circling the appropriate numbers. Each criterion must receive a rating of “3” or higher to demonstrate student mastery. (See Key below.) A student who is unable to demonstrate mastery should review the material and submit another product for evaluation.

Criteria:

Safety	4	3	2	1
Used level correctly	4	3	2	1
Overall performance	4	3	2	1

AVERAGE RATING

Evaluator note: To obtain an average rating for the Profile of Training Mastery, total the points in Product Evaluation and divide by the total number of criteria. Circle the rating on the Key.

KEY

- 4 Skilled** — Can perform job with no additional training
- 3 Moderately Skilled** — Has performed job during training program; limited additional training may be required
- 2 Limited Skill** — Has performed job during training program; additional training is required to develop skill
- 1 Unskilled** — Is familiar with process, but is unable to perform job

EVALUATOR'S COMMENTS





Name _____ Score _____

OBJECTIVE 7

Set pipe screeds using builder's level or laser level.

BASIC SKILLS



Employability

**EQUIPMENT
AND SUPPLIES**

- Sledge hammer
- Claw hammer
- Folding rule or tape
- Line
- Builder's level or laser level and rod
- 1½-inch diameter pipe
- Wooden stakes
- Nails
- Personal protective equipment

✓ **NOTE:** Refer to C.F.R. 1926.28 Sub Part C in regard to personal protective equipment.

PROCEDURE

✓ **NOTE:** There are various types of screeds that may be used; basically all are set the same way.

Yes No

1. Establish the screed location.
- A. measure across one end of the forms to determine the width of the pour (28'-0")
 - B. Divide the area into three equal parts (9'-4")
 - C. Mark the location for the end stakes on each side of the form.
2. Set the stakes at each marked screed location.



Yes No

3. Stretch a line between two stakes from point 1 to point 2.

✓ **NOTE:** The line is used as a guide to drive intermediate stakes in a straight line and at an approximate grade.

4. Drive intermediate stakes approximately four feet apart.

✓ **NOTE:** The distance between stakes will vary according to the length of the pipe. They should be placed closer together for small-diameter pipe to prevent sagging.

5. Set up the level and establish the grade.

6. Using the builder's level or laser level and rod to check grade, drive stakes one and one-half inches (the thickness of pipe) below the finished floor grade. (Figure 1)



FIGURE 1

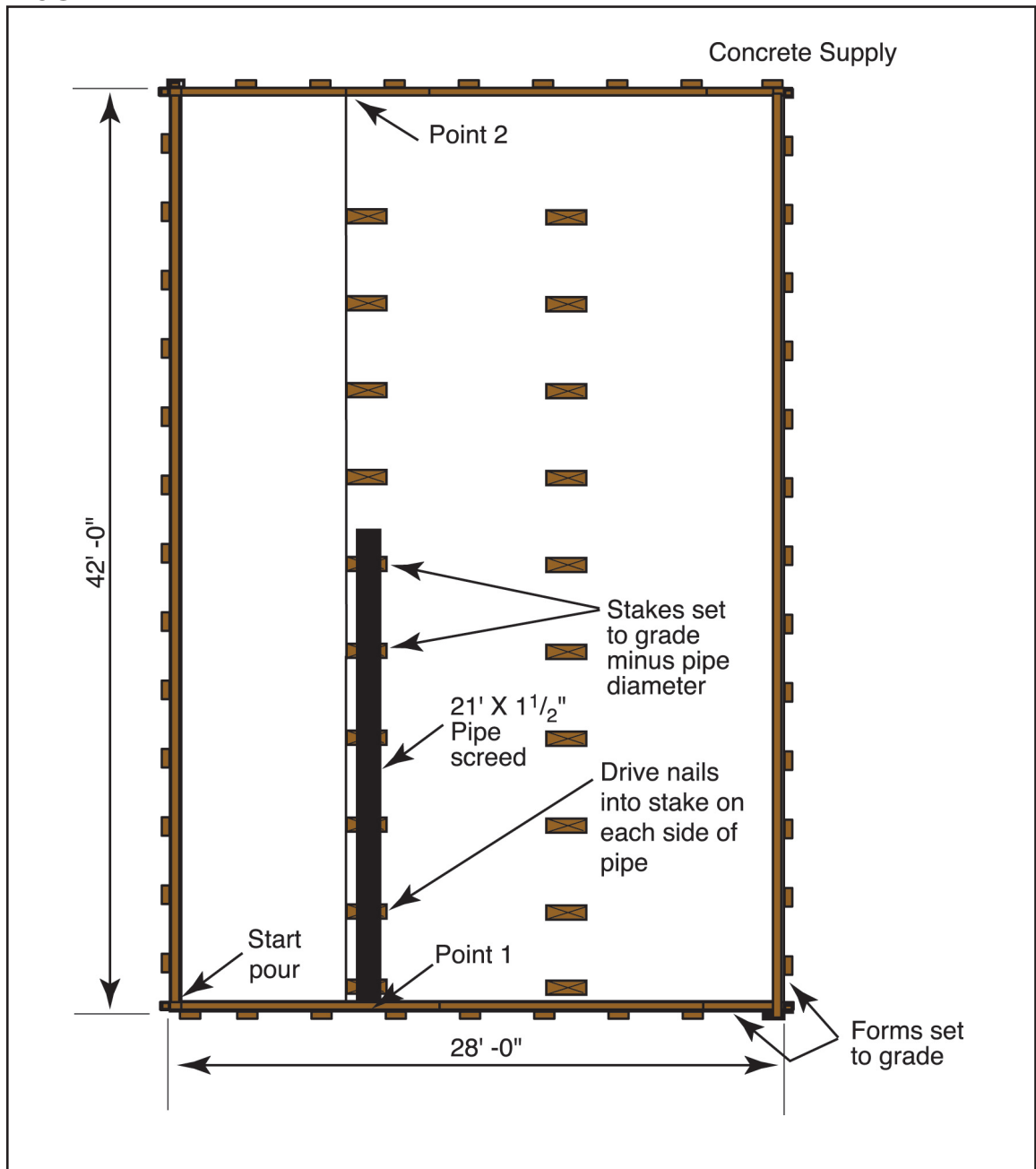

✓ **NOTE:** Stakes and pipe have been enlarged for clarity.



Yes No

- 7. Place the pipe on the stakes and drive nails into the stakes on each side of the pipe screed to hold it in position.
- 8. Take shots at various points on top of the pipe to spot check screed grade. (Figure 2)

FIGURE 2

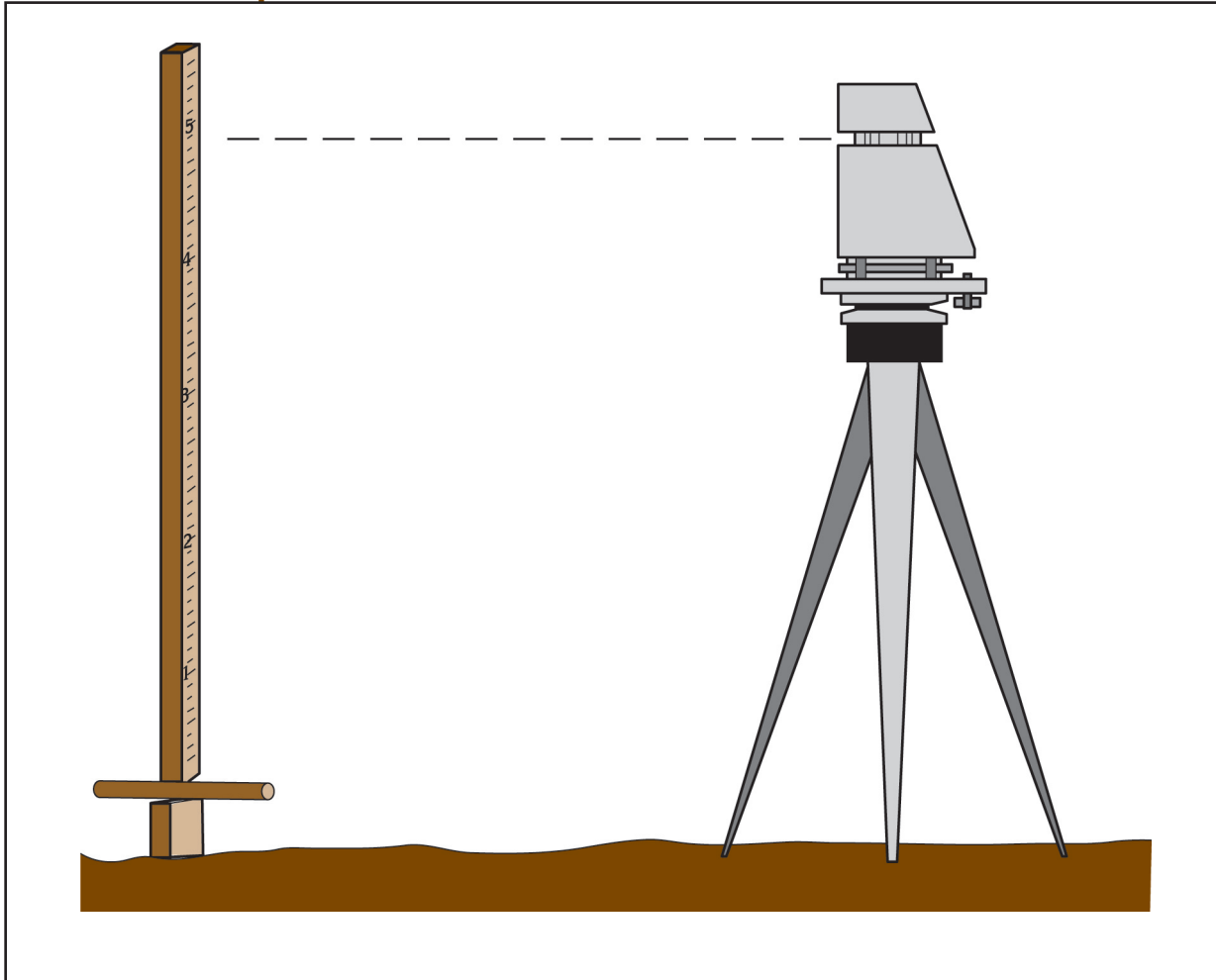

- 9. Have the instructor check your work.
- 10. Clean the work area and return tools and equipment to proper storage.



SKILL TEST RECORD

PRODUCT EVALUATION

Evaluator note: Rate the student on the following criteria by circling the appropriate numbers. Each criterion must receive a rating of “3” or higher to demonstrate student mastery. (See Key below.) A student who is unable to demonstrate mastery should review the material and submit another product for evaluation.

Criteria:

Safety	4	3	2	1
Used level correctly	4	3	2	1
Overall performance	4	3	2	1

AVERAGE RATING

Evaluator note: To obtain an average rating for the Profile of Training Mastery, total the points in Product Evaluation and divide by the total number of criteria. Circle the rating on the Key.

KEY

- 4 Skilled** — Can perform job with no additional training
- 3 Moderately Skilled** — Has performed job during training program; limited additional training may be required
- 2 Limited Skill** — Has performed job during training program; additional training is required to develop skill
- 1 Unskilled** — Is familiar with process, but is unable to perform job

EVALUATOR'S COMMENTS





Name _____ Score _____

OBJECTIVE 8

Set grade stakes using a builder's level or laser level.

BASIC SKILLS



Employability

EQUIPMENT AND SUPPLIES

- Sledge hammer
- Builder's level or laser level and rod
- Stakes
- Personal protective equipment

✓ **NOTE:** Refer to C.F.R. 1926.28 Sub Part C in regard to personal protective equipment.

PROCEDURE

Yes No

1. Establish grade stake location.

✓ **NOTE:** Grade stakes are used to establish a wet screed and rod to the shortest distance.

2. Drive the grade stakes. (Figure 1)

FIGURE 1

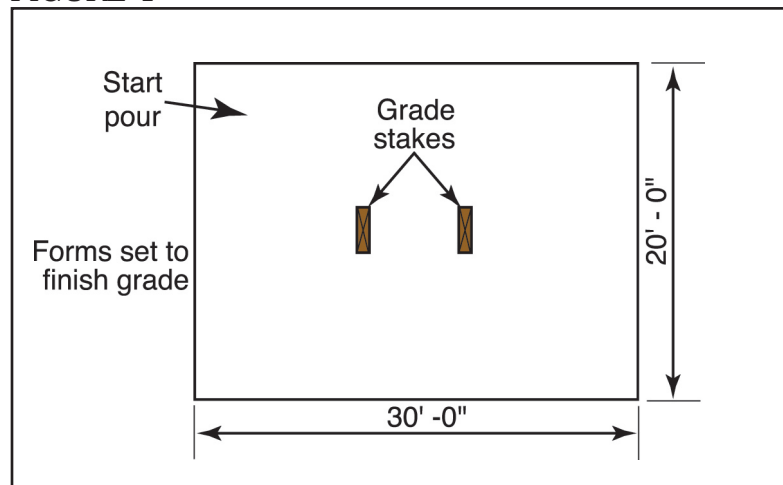

Yes No

- 3. Set up the builder's or laser level and establish grade.
- 4. Place the leveling rod on the stake and shoot the grade with the level. (Figure 2)

FIGURE 2

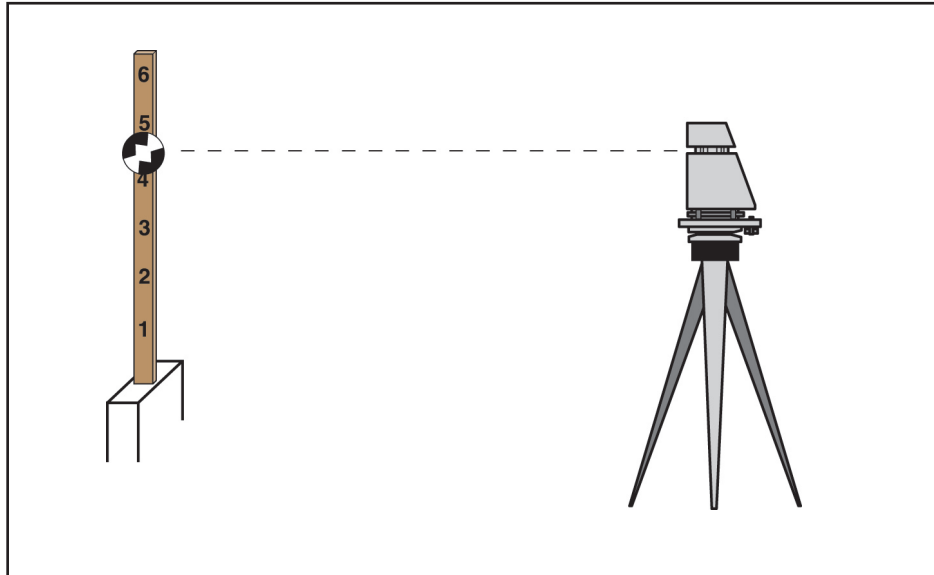

- 5. Drive the stake down until it is on grade.

✓ NOTE: When pouring concrete, stakes must be removed or driven flush with subgrade after screeding.
- 6. Repeat steps 4 and 5 for all grade stakes.
- 7. Have the instructor check your work.
- 8. Clean the work area and return tools and equipment to proper storage.



SKILL TEST RECORD

PRODUCT EVALUATION

Evaluator note: Rate the student on the following criteria by circling the appropriate numbers. Each criterion must receive a rating of “3” or higher to demonstrate student mastery. (See Key below.) A student who is unable to demonstrate mastery should review the material and submit another product for evaluation.

Criteria:

Safety	4	3	2	1
Used level correctly	4	3	2	1
Overall performance	4	3	2	1

AVERAGE RATING

Evaluator note: To obtain an average rating for the Profile of Training Mastery, total the points in Product Evaluation and divide by the total number of criteria. Circle the rating on the Key.

KEY

- 4 Skilled** — Can perform job with no additional training
- 3 Moderately Skilled** — Has performed job during training program; limited additional training may be required
- 2 Limited Skill** — Has performed job during training program; additional training is required to develop skill
- 1 Unskilled** — Is familiar with process, but is unable to perform job

EVALUATOR'S COMMENTS





Name _____ Score _____

OBJECTIVE 9

Set grade stakes using a hand level, straightedge, and stringline.

BASIC SKILLS



Employability

EQUIPMENT AND SUPPLIES

- Sledge hammer
- Spirit level
- Straightedge
- Stakes
- Nylon stringline
- Personal protective equipment

✓ **NOTE:** Refer to C.F.R. 1926.28 Sub Part C in regard to personal protective equipment.

PROCEDURE

Yes No

- 1. Establish grade stake location
- 2. Drive the stakes.
- 3. Place one end of the straightedge on the form that is set to grade at point 1 and the other end on the stake at point 2.
- 4. Place the level on top of the straightedge. (Figure 1)



FIGURE 1

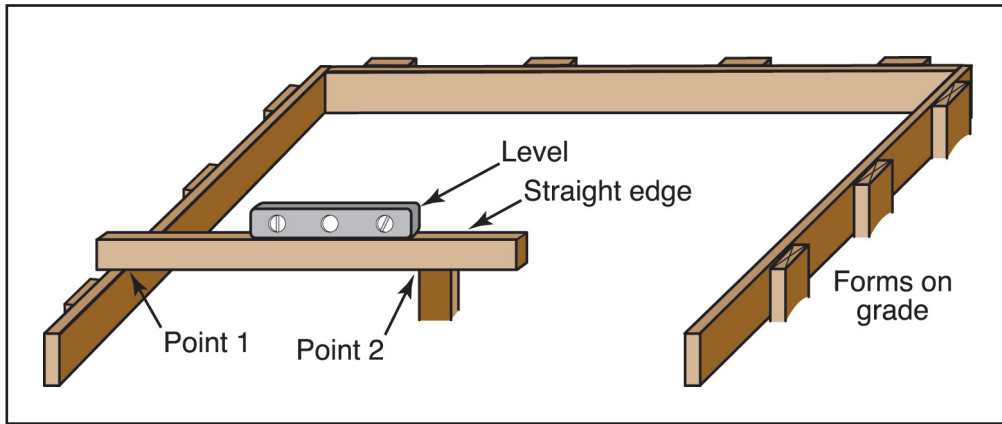

Yes No

- 5. Drive the stake down until it is level with the form.
- 6. Using another stake, establish the grade by using the stringline method.
- 7. Stretch the line from point 1 to point 3. (Figure 2)
- 8. Drive the stake to stringline elevation.
- 9. You may cross check your work by reversing your methods.

FIGURE 2

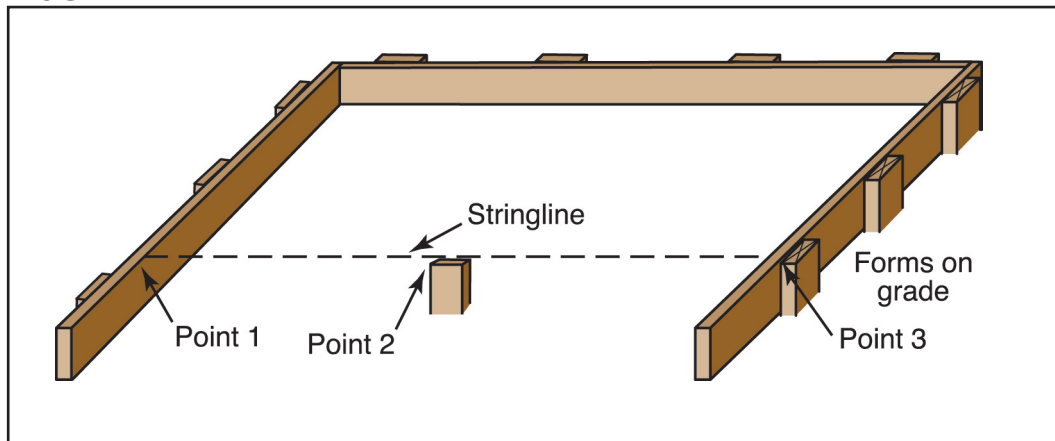

- 10. Have the instructor check your work.
- 11. Clean the work area and return tools and equipment to proper storage.



SKILL TEST RECORD

PRODUCT EVALUATION

Evaluator note: Rate the student on the following criteria by circling the appropriate numbers. Each criterion must receive a rating of “3” or higher to demonstrate student mastery. (See Key below.) A student who is unable to demonstrate mastery should review the material and submit another product for evaluation.

Criteria:

Safety	4	3	2	1
Used level correctly	4	3	2	1
Overall performance	4	3	2	1

AVERAGE RATING

Evaluator note: To obtain an average rating for the Profile of Training Mastery, total the points in Product Evaluation and divide by the total number of criteria. Circle the rating on the Key.

KEY

- 4 Skilled** — Can perform job with no additional training
- 3 Moderately Skilled** — Has performed job during training program; limited additional training may be required
- 2 Limited Skill** — Has performed job during training program; additional training is required to develop skill
- 1 Unskilled** — Is familiar with process, but is unable to perform job

EVALUATOR'S COMMENTS





Name _____ Score _____

OBJECTIVE 10

Set adjustable screed chairs using a builder's level or laser level.

BASIC SKILLS



Employability

EQUIPMENT AND SUPPLIES

- Folding rule or tape
- Builder's level or laser level and rod
- Adjustable screed chairs
- Adjustable wrench
- Personal protective equipment

✓ **NOTE:** Refer to C.F.R. 1926.28 Sub Part C in regard to personal protective equipment.

PROCEDURE

Yes No

- 1. Establish screed location.
- 2. Lay out the chairs. (Figure 1)

FIGURE 1

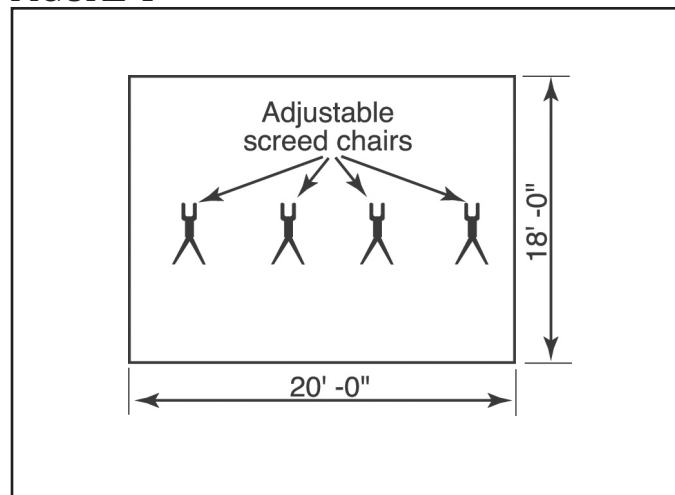

Yes No

3. Set up the builder's or laser level and establish grade.

✓ **NOTE:** Allow for the thickness of screed material when establishing grade.

4. Place the leveling rod on each chair and shoot grade with a builder's or laser level. (Figure 2)

FIGURE 2

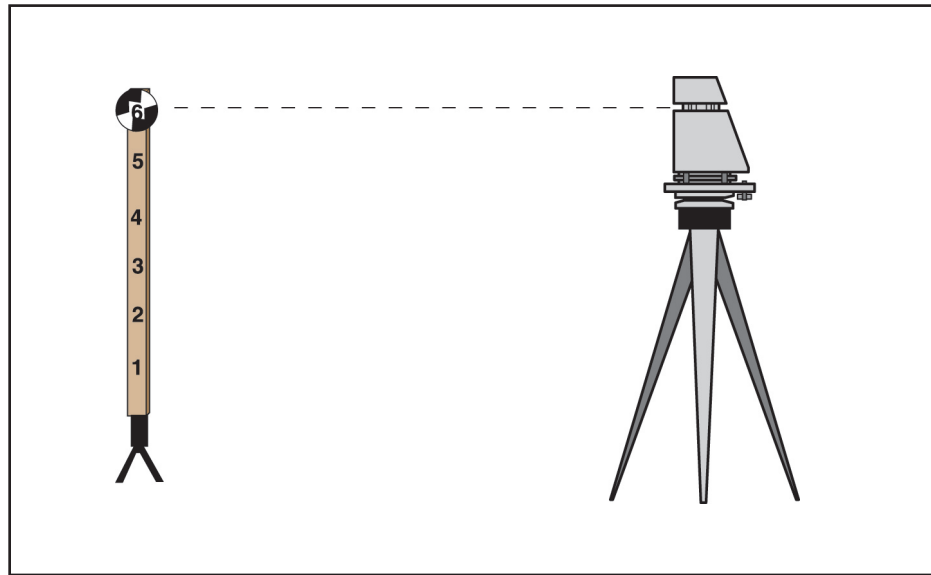

5. Screw the top of each chair up or down to the desired grade.

6. Have the instructor check your work.

7. Clean the work area and return tools and equipment to proper storage.



SKILL TEST RECORD

PRODUCT EVALUATION

Evaluator note: Rate the student on the following criteria by circling the appropriate numbers. Each criterion must receive a rating of “3” or higher to demonstrate student mastery. (See Key below.) A student who is unable to demonstrate mastery should review the material and submit another product for evaluation.

Criteria:

Safety	4	3	2	1
Used level correctly	4	3	2	1
Overall performance	4	3	2	1

AVERAGE RATING

Evaluator note: To obtain an average rating for the Profile of Training Mastery, total the points in Product Evaluation and divide by the total number of criteria. Circle the rating on the Key.

KEY

- 4 Skilled** — Can perform job with no additional training
- 3 Moderately Skilled** — Has performed job during training program; limited additional training may be required
- 2 Limited Skill** — Has performed job during training program; additional training is required to develop skill
- 1 Unskilled** — Is familiar with process, but is unable to perform job

EVALUATOR'S COMMENTS





Name _____ Score _____

OBJECTIVE 11

Set pins and saddles with a builder's or laser level and stringline.

WORDS YOU SHOULD KNOW

pin and saddle an adjustable bracket used to hold screeds

BASIC SKILLS



Employability

EQUIPMENT AND SUPPLIES

- Sledge hammer
Stringline
Stakes
Saddles
Adjustable wrench
Personal protective equipment

NOTE: Refer to C.F.R. 1926.28 Sub Part C in regard to personal protective equipment.

PROCEDURE 1

Yes No

- 1. Establish screed location
2. Drive in the stakes with the saddles.

NOTE: If heads of stakes are mushroomed you will not be able to put on the saddle. Make sure the bolt is functional and lubricated.

- 3. Place the level rod on the saddle, shoot in slightly high and tighten with a wrench.
4. With the leveling rod on saddle, tap it down to grade with a hammer.



PROCEDURE 2

Yes No

- 5. Have the instructor check your work.
- 6. Clean the work area and return tools and equipment to proper storage.

Yes No

- 1. Stretch a line tight along the screed line (shortest distance).
- 2. Drive in the stakes close to the string.
- 3. Set the saddles to string height.



SKILL TEST RECORD

PRODUCT EVALUATION

Evaluator note: Rate the student on the following criteria by circling the appropriate numbers. Each criterion must receive a rating of “3” or higher to demonstrate student mastery. (See Key below.) A student who is unable to demonstrate mastery should review the material and submit another product for evaluation.

Criteria:

Ribbon squeezed	4	3	2	1
Texture determined	4	3	2	1

AVERAGE RATING

Evaluator note: To obtain an average rating for the Profile of Training Mastery, total the points in Product Evaluation and divide by the total number of criteria. Circle the rating on the Key.

KEY

- 4 Skilled** — Can perform job with no additional training
- 3 Moderately Skilled** — Has performed job during training program; limited additional training may be required
- 2 Limited Skill** — Has performed job during training program; additional training is required to develop skill
- 1 Unskilled** — Is familiar with process, but is unable to perform job

EVALUATOR'S COMMENTS



