

INTRODUCTION

Concrete steps are preferred by many builders because of their strength and versatility. There are two basic forms of steps: solid fill base, in which the steps are earth supported, and open, in which the steps are suspended with support at the top and bottom. A third type is precast which is poured and cured at a plant and then moved to the construction site. This unit will focus on the solid fill base and the open types of steps. The construction of formwork for both of these types of steps begins with measuring the stairwell and determining the number of steps needed.

**FOCUS
ASSIGNMENTS**

FOCUS ASSIGNMENTS

1. Make sketches of steps and stairways that you see or use everyday.
2. Participate in a class discussion with your instructor about why a particular type of stair design was chosen for a particular stairwell.



Writing



Mathematics



Critical Thinking

**UNIT
OBJECTIVE**

After completing this unit, you will show the following competencies by mastering the activities on the Assignment and Job Sheets and by scoring at least 85% on the Written Test.

**SPECIFIC
OBJECTIVES**

1. Name types of steps.
2. Identify types of stair forms.
3. Identify parts of a stair form.
4. State rules for unit rise and unit run.
5. Arrange in order the steps for determining the size and number of risers and treads for a stair.
6. Calculate size and number of stair risers and treads for stairwells of given dimensions. (Assignment Sheet)



7. Explain briefly where to start placing concrete in stair forms.
8. Name types of nosings and treads used on concrete steps.
9. Name reasons for using low slump concrete in stair forms.
10. Construct forms for a solid set of stairs. (Job Sheet 1)
11. Construct forms for earth-supported stairs with open sides. (Job Sheet 2)
12. Construct forms for suspended stairs with open sides. (Job Sheet 3)
13. Place and finish concrete steps with a fine swirl finish. (Job Sheet 4)
14. Place and finish concrete steps in metal pan forms with a nonskid finish. (Job Sheet 5)
15. Place and finish concrete steps with nosings and pipe inserts. (Job Sheet 6)



OBJECTIVE 1

Required Activities/
Resources
– Transparency 1

Optional Activities/
Resources in Instructor's
Guide

Name types of steps.



Your instructor will show you a transparency about different types of steps.

WORDS YOU SHOULD KNOW

precast steps	concrete cast in forms at precast plant, cured, and then moved to job site and set into position
riser	vertical part of a step
tread	horizontal part of a step

- Solid-fill base (earth-supported) (Figure 1)

FIGURE 1

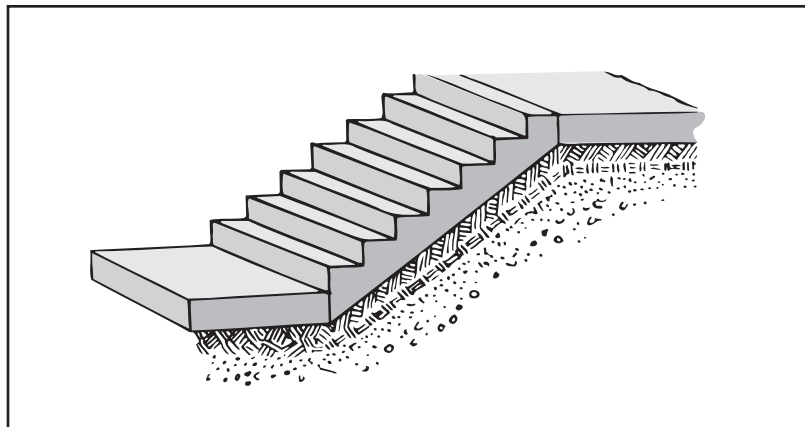

- Open (suspended) (Figure 2)

FIGURE 2

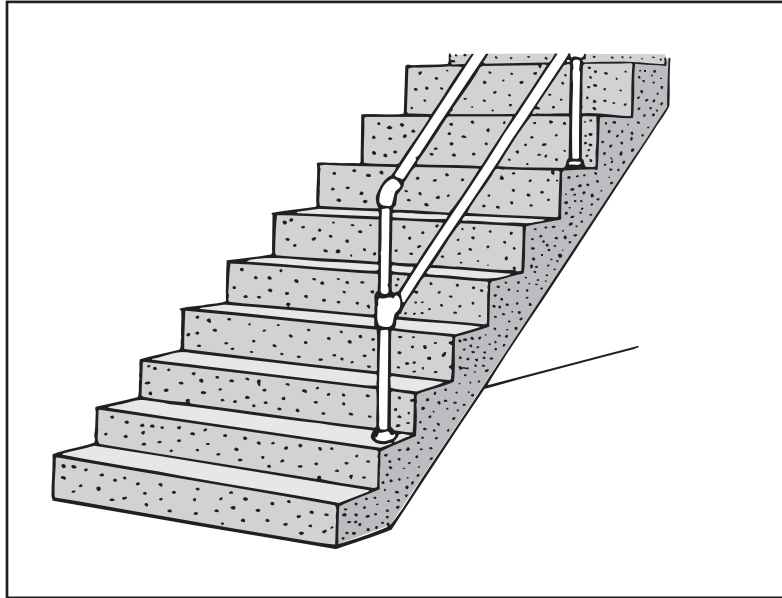

- Precast (Figure 3)

FIGURE 3

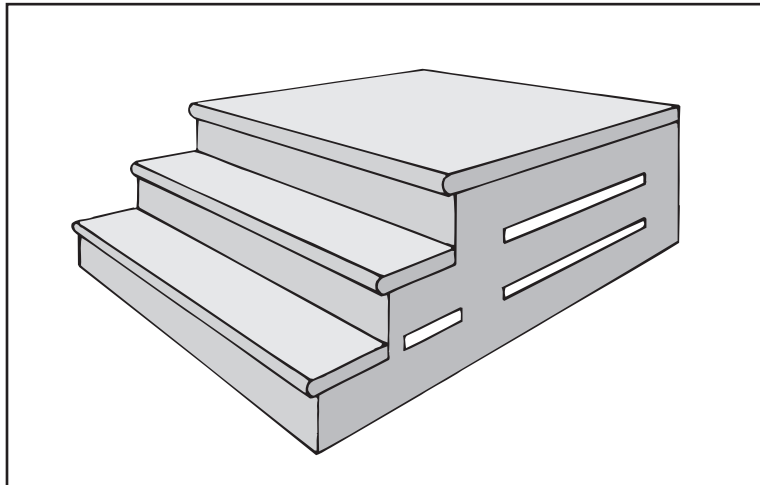

- Open metal pan (no risers) (Figure 4)

FIGURE 4

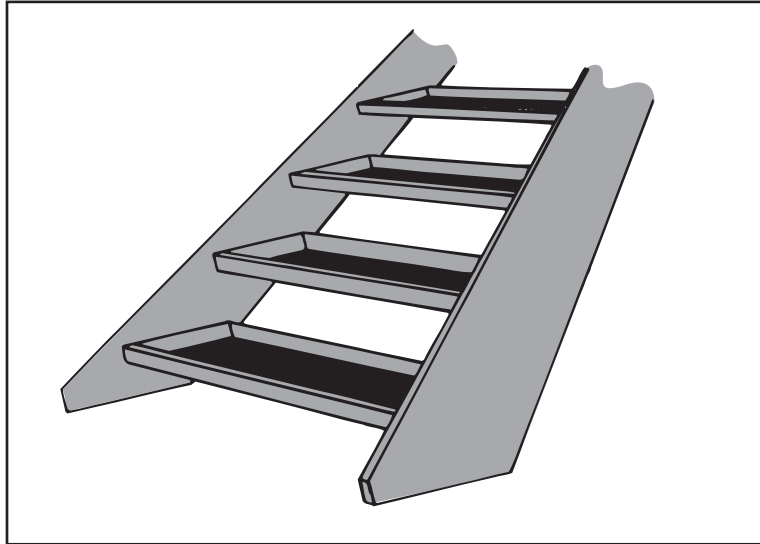

- Closed metal pan (metal risers) (Figure 5)

FIGURE 5

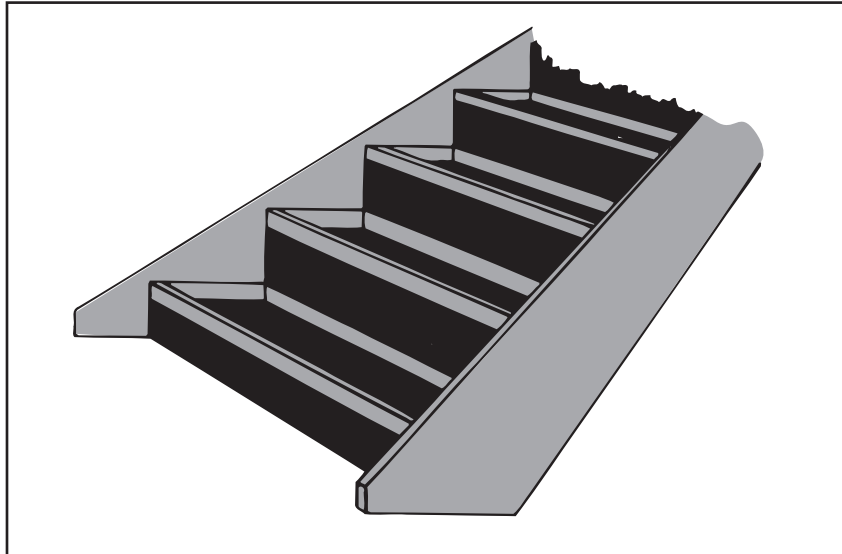

OBJECTIVE 2

Required Activities/
Resources
— Transparencies 2, 3, 4,
and 5

Optional Activities/
Resources in Instructor's
Guide

Identify types of stair forms.



Your instructor will show you transparencies about different types of stair forms.

- Suspended wood forms for stairs open on sides (Figure 6)

FIGURE 6

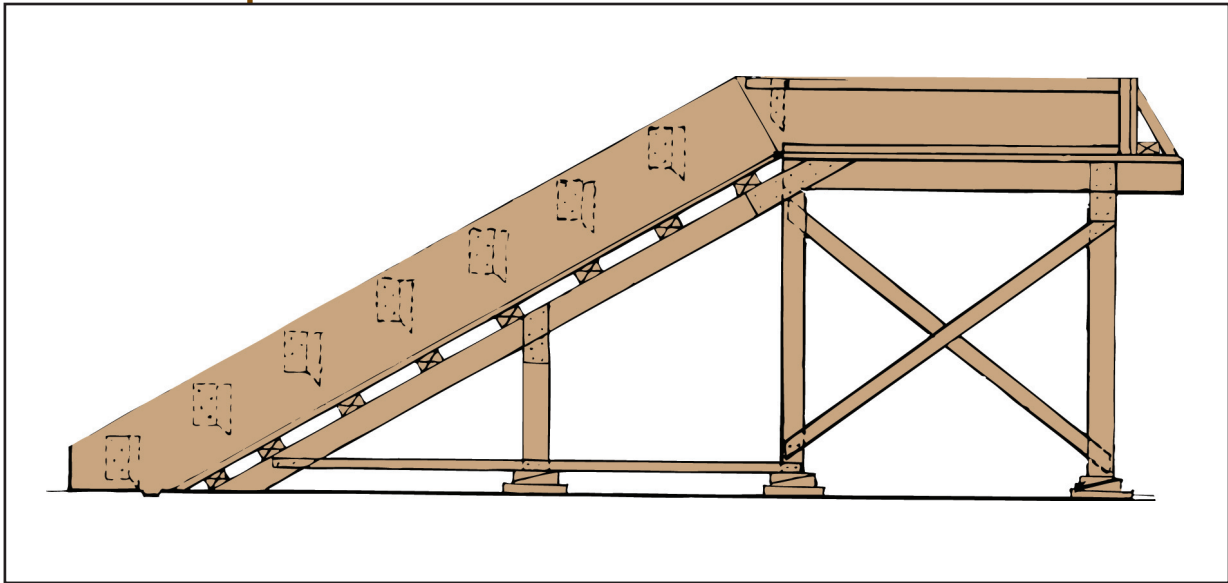

EXAMPLE: Section view (Figure 7)

FIGURE 7

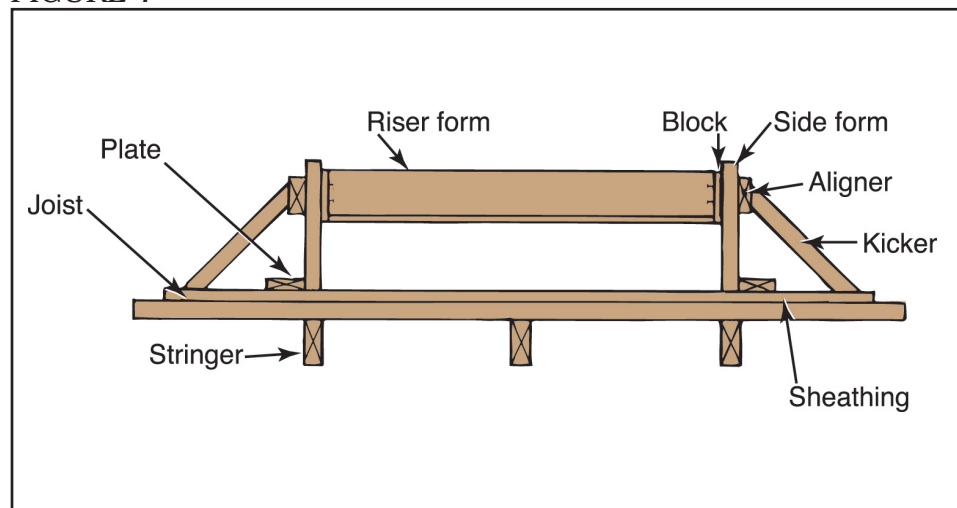

- Suspended between walls

✓ **NOTE:** If stairs are 4 feet wide or wider, it is necessary to add a center stringer or center braces as shown below. (Figure 8)

FIGURE 8

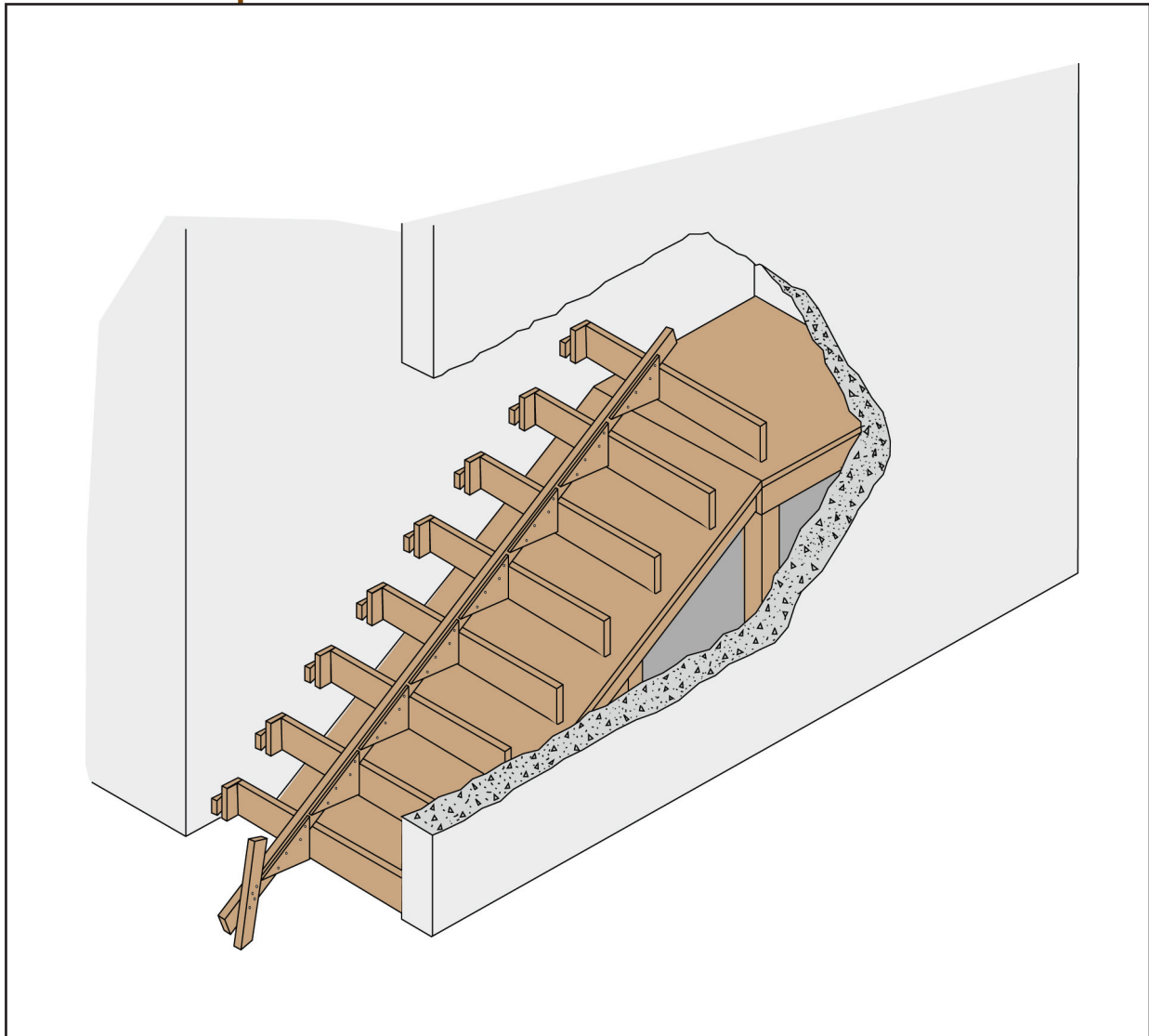

EXAMPLE: Plan view (Figure 9)

FIGURE 9

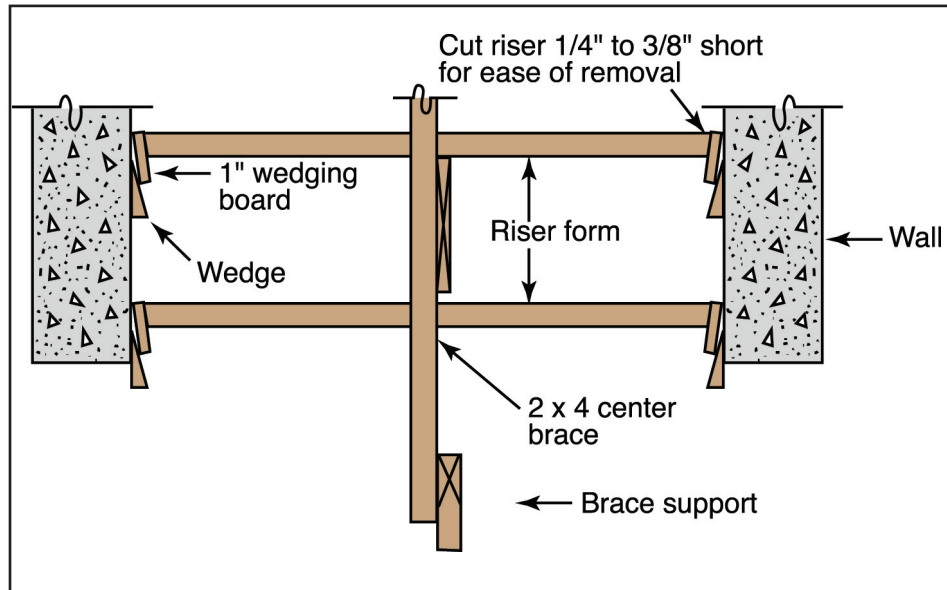

- Earth-supported between walls

✓ **NOTE:** If stairs are 4 feet wide or wider, it is necessary to add a center stringer or center braces as shown below. (Figure 10)

FIGURE 10

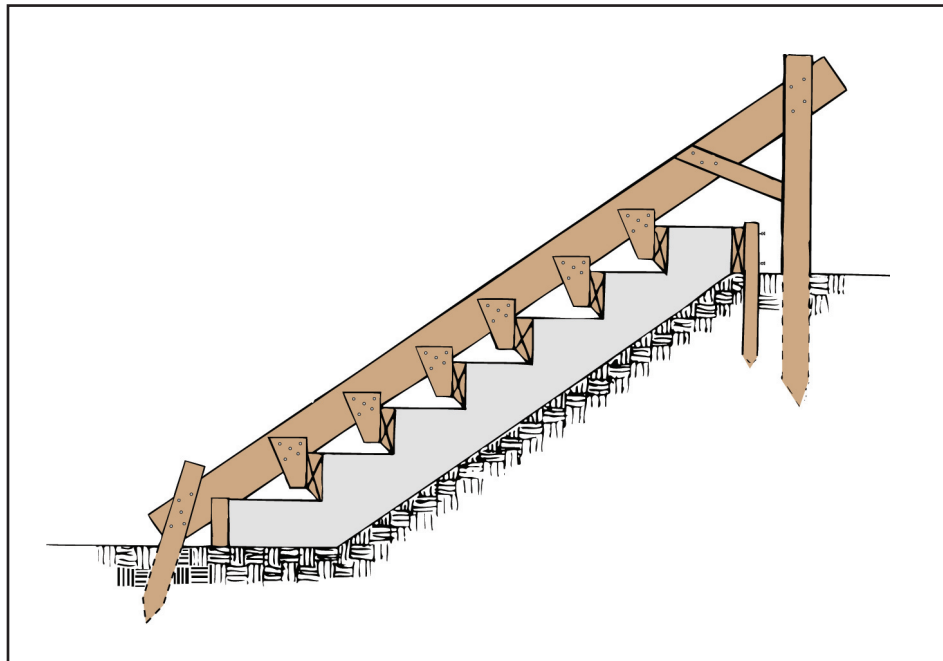

EXAMPLE: Plan view (Figure 11)

FIGURE 11

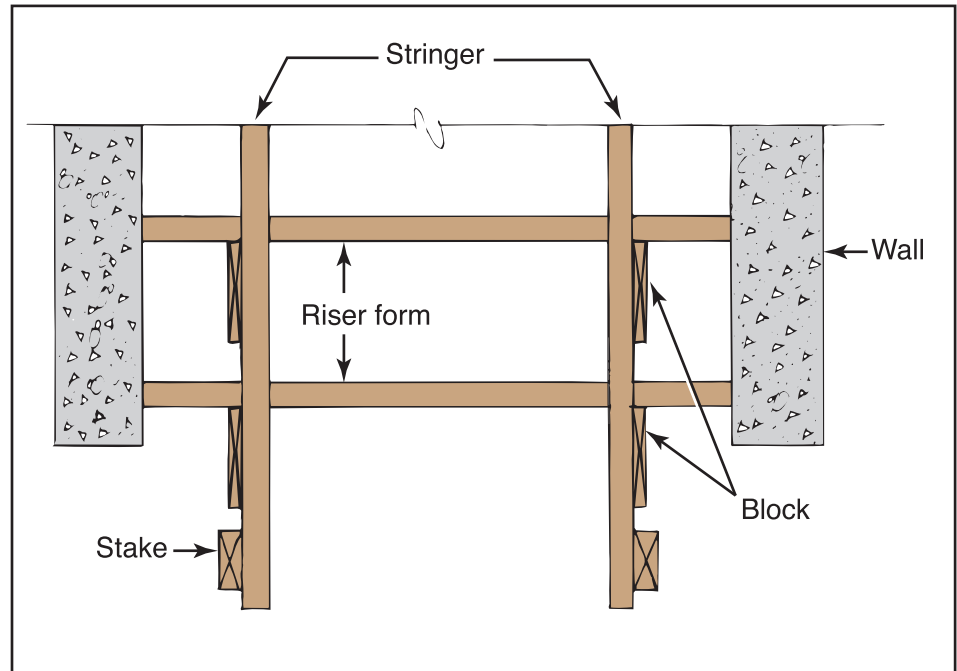

- Earth-supported for stairs open on sides (Figure 12)

FIGURE 12

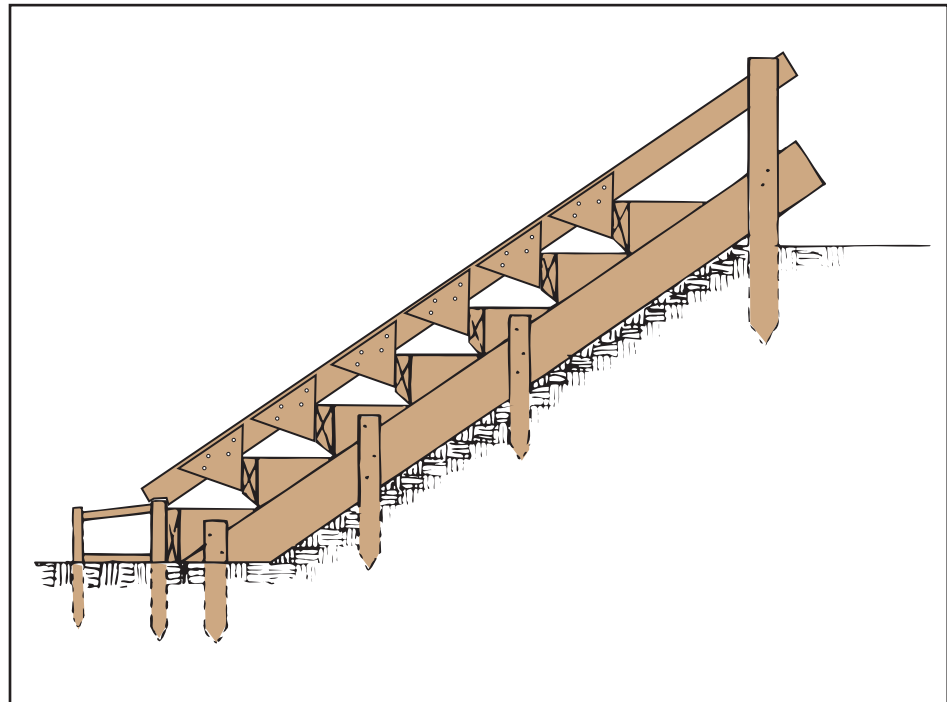

EXAMPLE: Elevation view (Figure 13)

FIGURE 13

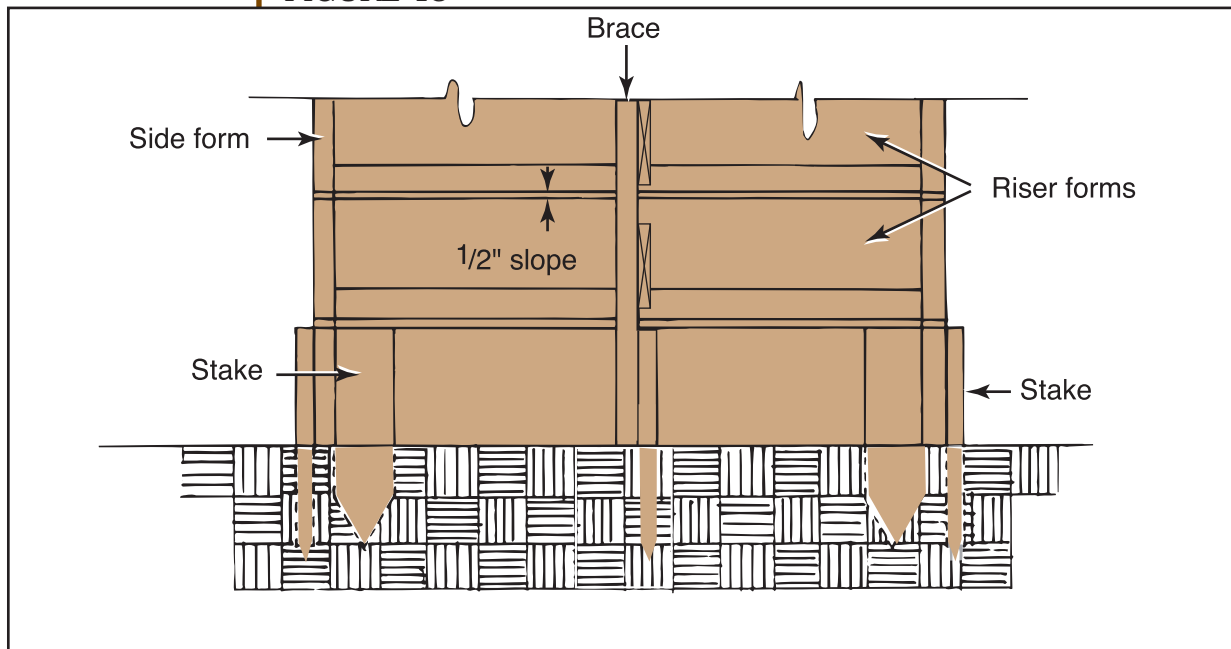

OBJECTIVE 3

Required Activities/
Resources
– Transparency 6

Optional Activities/
Resources in Instructor's
Guide

Identify parts of a stair form.



Your instructor will show you a transparency about the different parts of a stair form.

WORDS YOU SHOULD KNOW

stair stringer inclined supporting member of a stair form

FIGURE 14

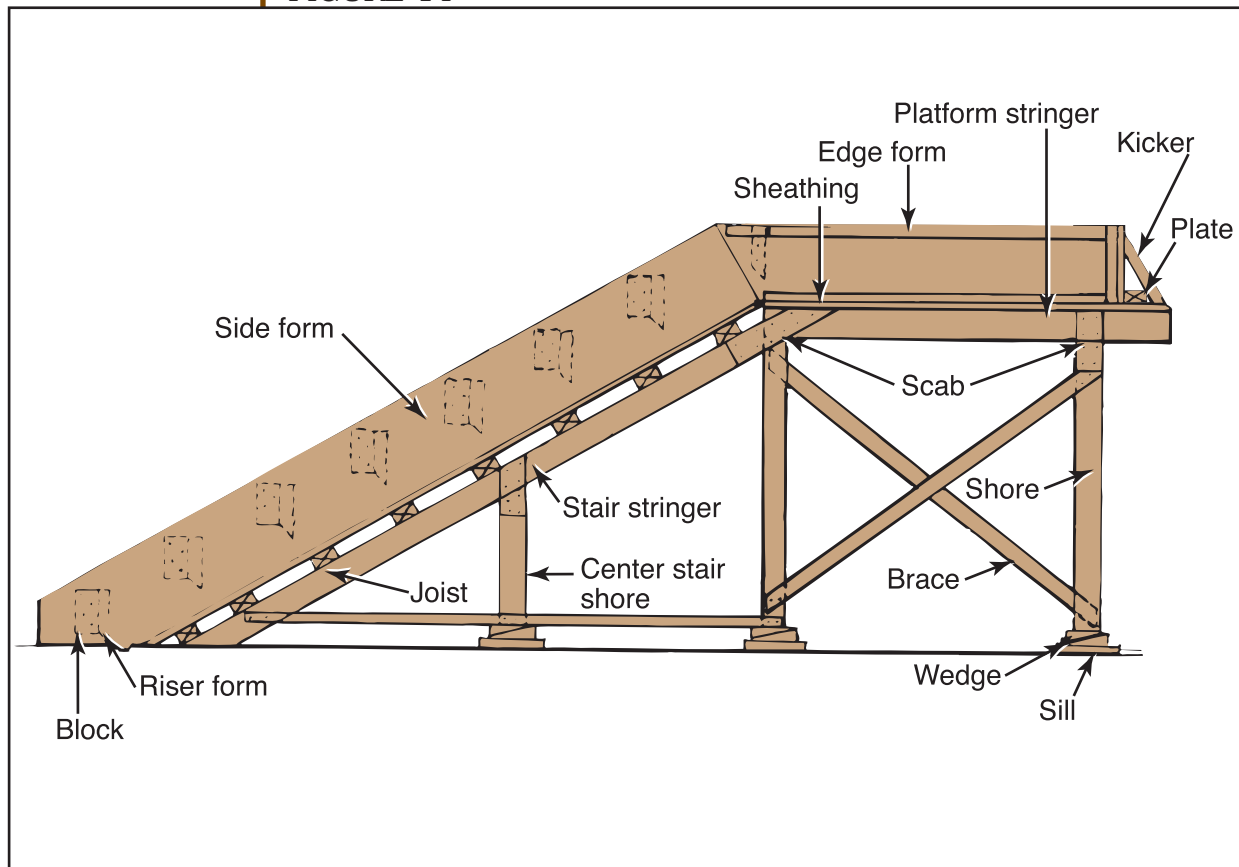

OBJECTIVE 4

Required Activities/
Resources
– Transparency 7

Optional Activities/
Resources in Instructor's
Guide

State rules for unit rise and unit run.



Your instructor will show you a transparency about the rules for rise and run on stairs.

WORDS YOU SHOULD KNOW

unit rise	vertical distance from the top of a tread in a stairway to the top of the next tread
unit run	horizontal distance from the face of a riser in a stairway to the face of the next riser
stair well	compartment extending vertically through a structure in which stairs are constructed

- The total of one riser and one tread should be not less than 16 inches.
- Unit rise should be 7 inches to 8 inches.
- Unit run should be a minimum of 9 inches.
- ✓ **NOTE:** As the rise increases, the run must decrease proportionally.
- Treads and risers *must* be the same size as other treads and risers for any given set of stairs.
- ✓ **NOTE:** Always check your local building codes in determining unit rise and unit run.



OBJECTIVE 5

Arrange in order the steps for determining the size and number of risers and treads for a stair.

WORDS YOU SHOULD KNOW

fall	amount of slope from rear to front edge of step tread
-------------	---

- Risers

1. Determine total rise of the stair in inches.

✓ **NOTE:** Total rise of a stair is from the finished floor of the lower level to the top of the finished floor of the upper level.

2. Divide total rise of the stair by 7 to find the number of risers needed.

✓ **NOTE:** Seven inches is the minimum height of a riser.

3. Round back to the nearest whole number.

EXAMPLE: Total rise is 7' - 10¼", or 94¼ inches

$94\frac{1}{4} \text{ inches} \div 7 = 13.46 \text{ inches or } 13\frac{7}{16} \text{ inches each}$

$\frac{7}{16}$ inch will not make a full riser, so round back to 13 full risers.

4. Divide total rise by the number of risers.

EXAMPLE: $94\frac{1}{4} \text{ inches} \div 13 = 7\frac{1}{4} \text{ inches}$

There would be 13 risers of 7¼ inches each.

- Treads

1. Determine the total run of the stair in inches.

✓ **NOTE:** Total run of the stair is the horizontal distance from a point at the head of the stair to the outside edge of the last riser.



2. Determine the number of treads by subtracting 1 from the number of risers.

✓ **NOTE:** There is always one less tread than there are risers.

3. Divide the total run by the number of treads.

EXAMPLE: Total run is 9' - 9" or 117 inches.

$117 \text{ inches} \div 12 = 9.75 \text{ inches or } 9\frac{3}{4} \text{ inches}$
unit run.

There will be 12 treads of $9\frac{3}{4}$ inches each.

✓ **NOTE:** If stairs are exterior or subject to standing water, allow for fall.

OBJECTIVE 6

Complete the Assignment Sheet.



OBJECTIVE 7

Required Activities/
Resources
– Transparency 8

Optional Activities/
Resources in Instructor's
Guide

Explain briefly where to start placing concrete in stair forms.



Your instructor will show you a transparency on placing concrete in stair forms.

- Stair forms should be filled starting at the top step. (Figure 15)

FIGURE 15

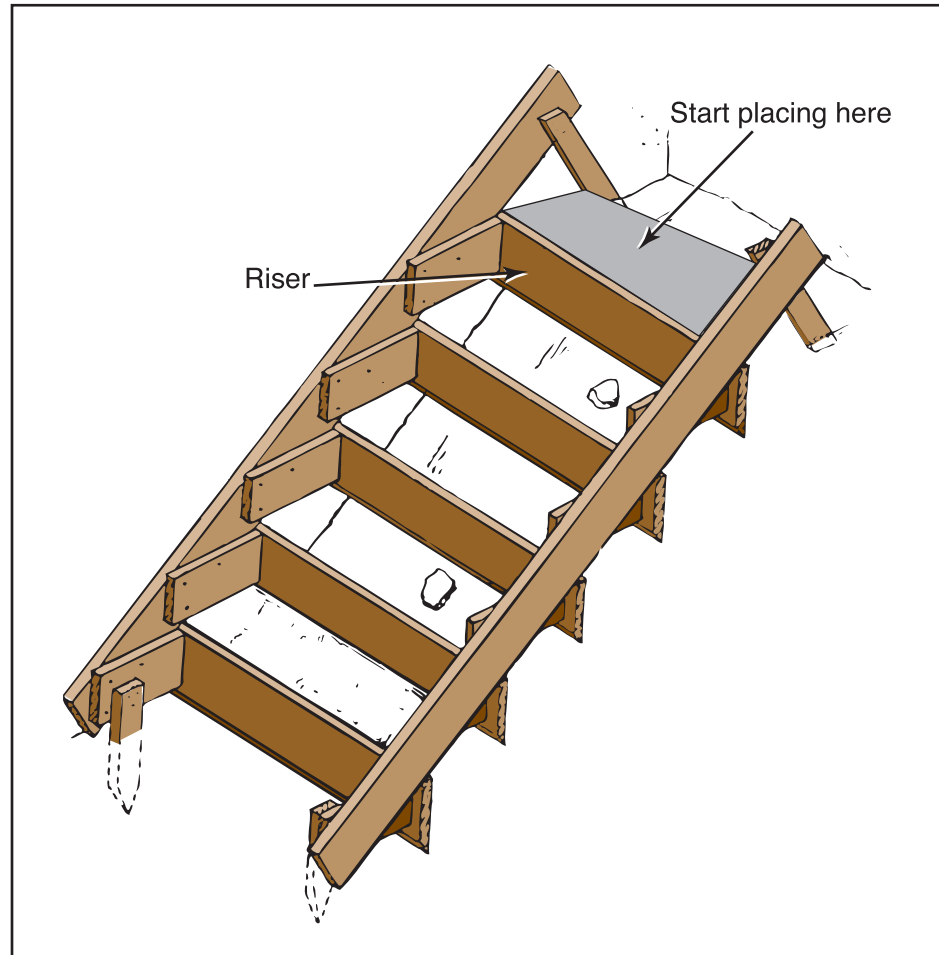

OBJECTIVE 8

Required Activities/
Resources
– Transparency 9

Optional Activities/
Resources in Instructor's
Guide

Name types of nosings and treads used on concrete steps.



Your instructor will show you a transparency on the different types of nosing and treads used on concrete steps.

WORDS YOU SHOULD KNOW

nosing and tread device molded from cast iron, aluminum, or abrasive material used on the front edge and tread of concrete steps

safety step edger/groover special type of combination tool used to shape nosing and grooves in step tread

- Small plain nosing (Figure 16)

FIGURE 16



- Metal nosing with abrasive tread (Figure 17)

FIGURE 17

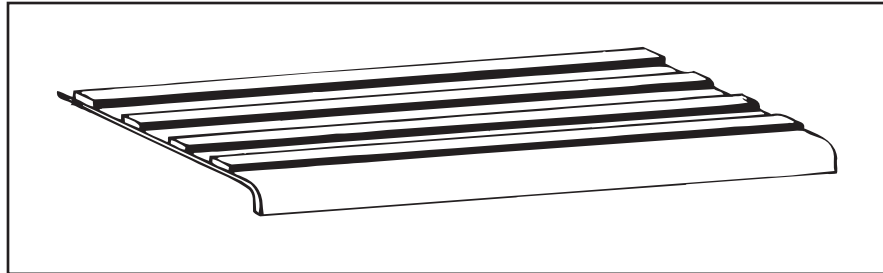

- Abrasive strips for tread (Figure 18)

FIGURE 18

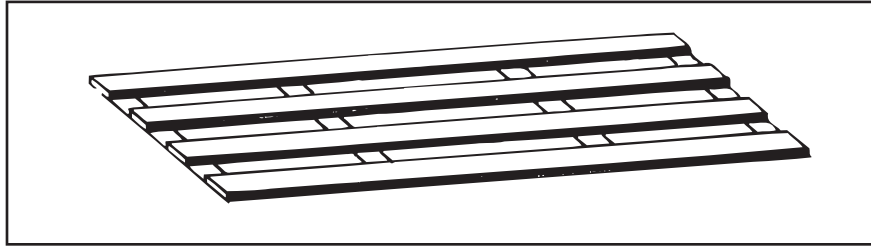

- Nosing and tread formed with combination safety edger/groover (Figure 19)

FIGURE 19

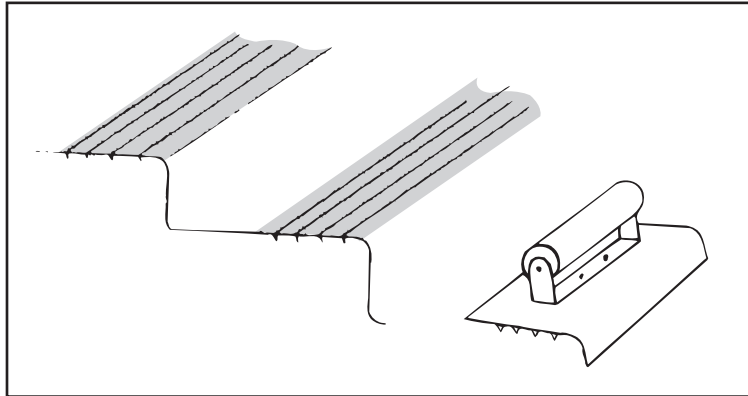

OBJECTIVE 9

Name reasons for using low slump concrete in stair forms.

WORDS YOU SHOULD KNOW

**low slump
concrete**

stiff concrete

- To prevent concrete from slumping into lower steps
- To prevent segregation
- To prevent excessive bleeding
- To promote faster set



OBJECTIVE 10 **Complete Job Sheet 1.**

OBJECTIVE 11 **Complete Job Sheet 2.**

OBJECTIVE 12 **Complete Job Sheet 3.**

OBJECTIVE 13 **Complete Job Sheet 4.**

OBJECTIVE 14 **Complete Job Sheet 5.**

OBJECTIVE 15 **Complete Job Sheet 6.**



Name _____ Score _____

OBJECTIVE 6

Calculate size and number of stair risers and treads for stairwells of given dimensions.

BASIC SKILLS



Mathematics



Employability

INTRODUCTION

Cement masons should be able to calculate the size and number of treads and risers accurately for a specific job. Accurate calculation is cost effective and eliminates mistakes and needless waste of material.

**EQUIPMENT
AND SUPPLIES**

- Pen or pencil
- Paper
- Calculator

INSTRUCTIONS

Calculate the number and size of stair risers and treads for the stairwells illustrated on the following pages.



1. A. Number and size of risers = _____

B. Number and size of treads = _____

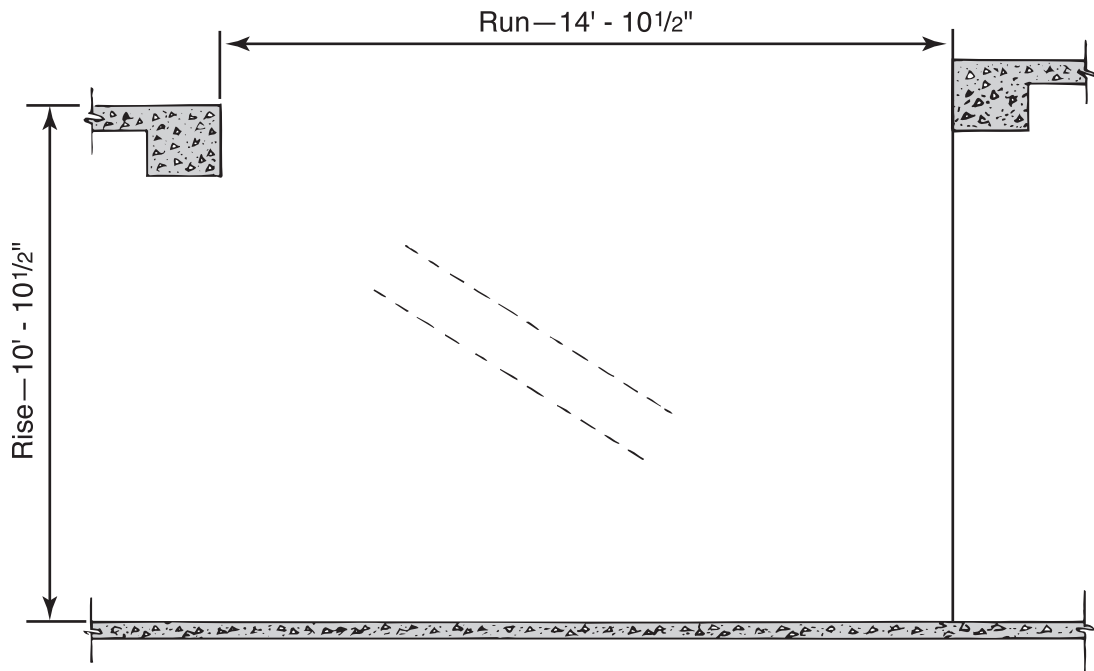

2. A. Number and size of risers = _____

B. Number and size of treads = _____

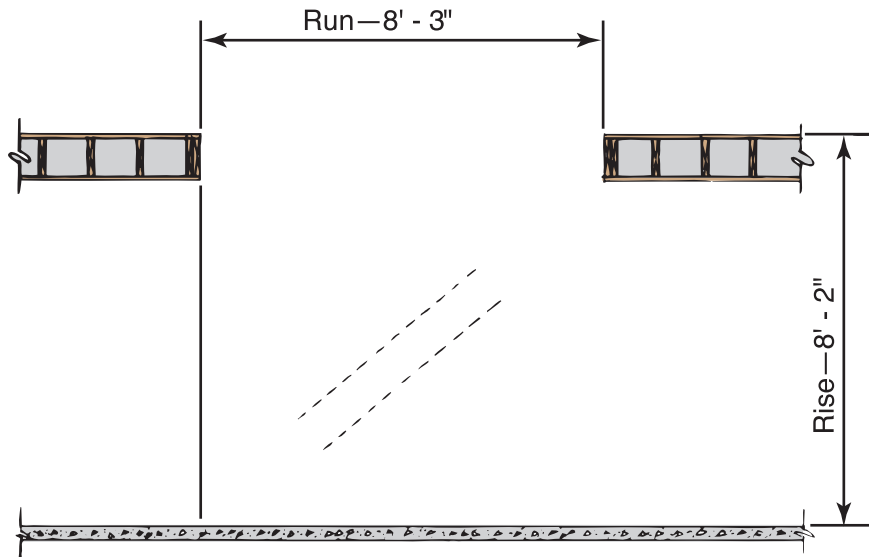

3. A. Number and size of risers = _____

B. Number and size of treads = _____

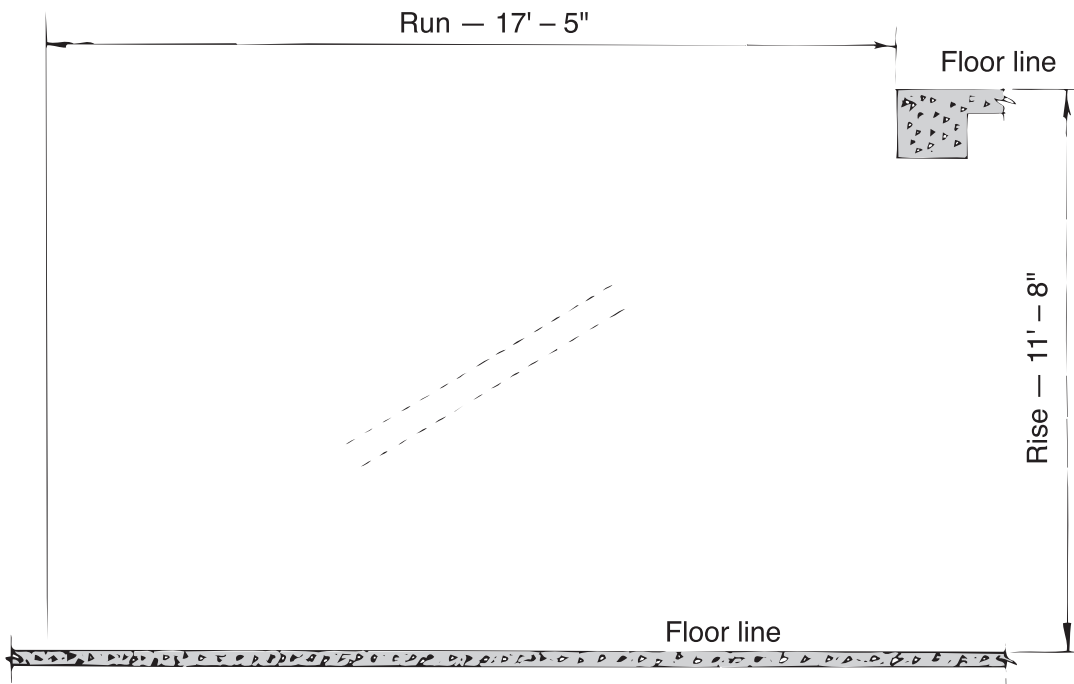



Name _____ Score _____

OBJECTIVE 10

Construct forms for a solid set of stairs.

WORDS YOU SHOULD KNOW

batter

forward inclination of a riser

BASIC SKILLS



Mathematics



Employability

EQUIPMENT AND SUPPLIES

- Claw hammer
- Handsaw
- Power handsaw and extension cord equipped with a ground-fault circuit interrupter



CAUTION: Use eye protection when operating power handsaw.

- Sledgehammer
- Stair gauges
- Framing square
- Hand level
- Electric drill and bits



CAUTION: Use eye protection when operating power drill.

- Folding rule or steel tape
- Plywood side forms
- 2 x 4s for stakes and stiffeners
- 2 x 8s for risers
- 1 x 4s for braces
- ½-inch conduit for spreaders
- Threaded rod for ties
- 8d and 16d duplex nails
- Personal protective equipment

✓ **NOTE:** Refer to C.F.R 1926.28 Sub Part C in regard to personal protective equipment.



PROCEDURE

Yes No

- 1. Determine the total rise and run.
- 2. Determine the number and size of risers and treads.
- 3. Determine the width and length of side forms. (Figure 1)

FIGURE 1

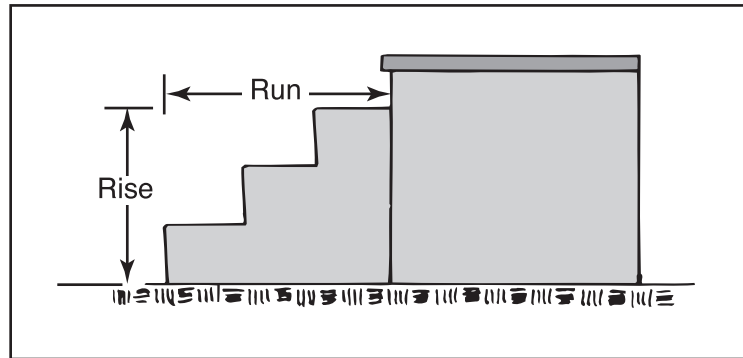

- 4. Cut the side forms to size.
- 5. Lay out steps on both forms, making a right- and left-hand layout. (Figure 2)

FIGURE 2

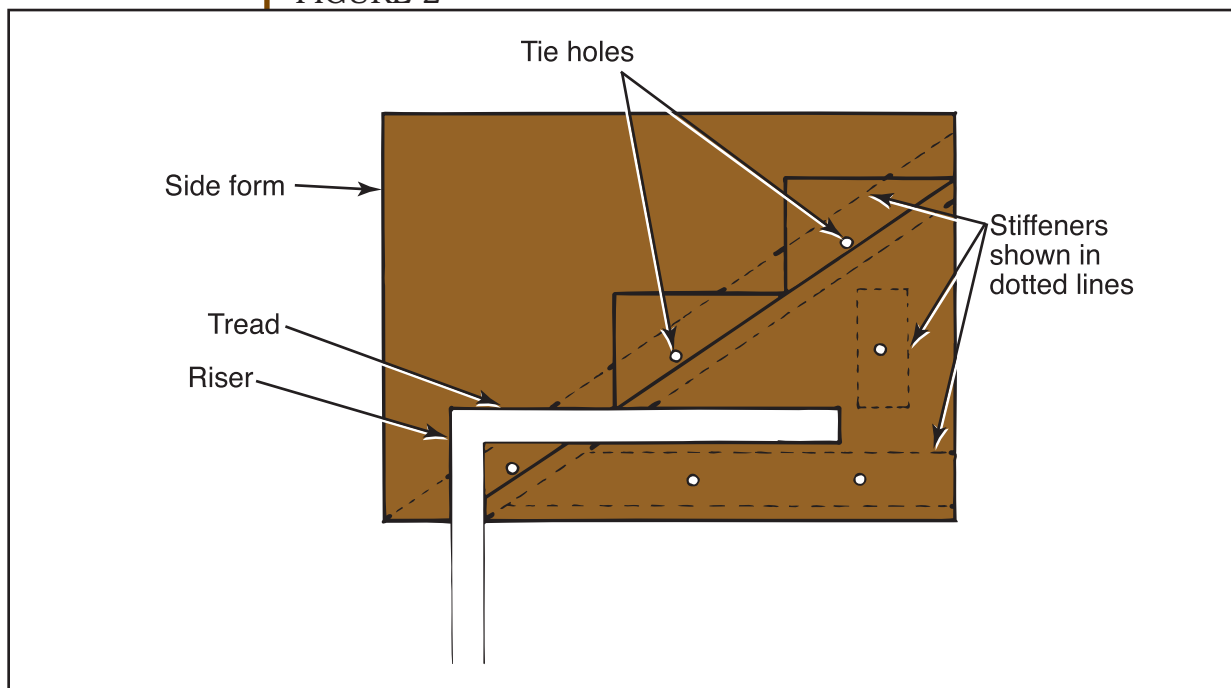

Yes No

- 6. Drill the tie holes in the pattern shown in the above figure, placing the forms back to back, and drilling both sets of holes at the same time.
- 7. Attach stiffeners to the back of forms, centering them on the holes; drill the tie holes in the stiffeners.
- 8. Cut the spreaders to length.

✓ **NOTE:** The spreaders will be as long as the stair is wide.

- 9. Cut the threaded rod to length.

✓ **NOTE:** The rods must be long enough to go through the forms on each side of the stairs with sufficient room for nuts, washers, and 1-inch projection at each end.

- 10. Size the riser forms.

A. Lay out the batter of the riser on the side form to determine the exact width.

B. Cut the riser form to width.

C. Cut the riser form to length.

✓ **NOTE:** Riser form length will be the same as the stair width.

D. Cut a 45-degree angle on the bottom edge of the riser to facilitate finishing. (Figure 3)

FIGURE 3

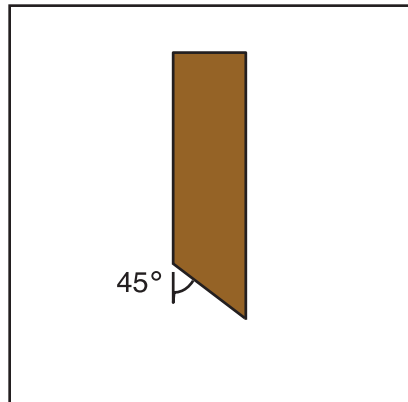

Yes No

14. Brace as shown above.

✓ **NOTE:** Very little bracing is needed on this type of form.

15. Check work for accuracy and plumb.

16. Have the instructor check your work.

17. Clean the work area and return tools and equipment to proper storage.



SKILL TEST RECORD

PRODUCT EVALUATION

Evaluator note: Rate the student on the following criteria by circling the appropriate numbers. Each criterion must receive a rating of “3” or higher to demonstrate student mastery. (See Key below.) A student who is unable to demonstrate mastery should review the material and submit another product for evaluation.

Criteria:

<u>Safety</u>	<u>4</u>	<u>3</u>	<u>2</u>	<u>1</u>
<u>Layout of risers and treads</u>	<u>4</u>	<u>3</u>	<u>2</u>	<u>1</u>
<u>Formwork</u>	<u>4</u>	<u>3</u>	<u>2</u>	<u>1</u>
<u>Overall performance</u>	<u>4</u>	<u>3</u>	<u>2</u>	<u>1</u>

AVERAGE RATING

Evaluator note: To obtain an average rating for the Profile of Training Mastery, total the points in Product Evaluation and divide by the total number of criteria. Circle the rating on the Key.

KEY

- 4 Skilled** — Can perform job with no additional training
- 3 Moderately Skilled** — Has performed job during training program; limited additional training may be required
- 2 Limited Skill** — Has performed job during training program; additional training is required to develop skill
- 1 Unskilled** — Is familiar with process, but is unable to perform job

EVALUATOR'S COMMENTS



Name _____ Score _____

OBJECTIVE 11

Construct forms for earth-supported stairs with open sides.

WORDS YOU SHOULD KNOW

stair gauge device attached to a framing square to ensure accuracy when laying out step material

BASIC SKILLS



Mathematics



Employability

EQUIPMENT AND SUPPLIES

- Claw hammer
- Handsaw
- Power handsaw and extension cord equipped with a ground-fault circuit interrupter



CAUTION: Use eye protection when operating power handsaw.

- Sledgehammer
- Stair gauges
- Hand level
- Builder's level
- Framing square
- Folding rule or steel tape
- Plywood forms
- 2 x 4 stakes
- 2 x 4s for aligners
- 2 x 8s for risers
- 2 x 4s for blocks
- 2 x 6s for stringers
- 1 x 4s for braces
- 8d and 16d duplex nails
- Personal protective equipment

✓ **NOTE:** Refer to C.F.R 1926.28 Sub Part C in regard to personal protective equipment.



PROCEDURE

Yes No

1. Determine the total rise and run.
2. Determine the number and height of risers and the number and width of treads.
3. Determine the width and length of the side form from rise and run. (Figure 1)

✓ **NOTE:** Form width will be the slab thickness plus the riser height and 2 inches. Form length will be the length of the pitch of one step times the number of steps in the flight plus 1 foot for overhang.

FIGURE 1

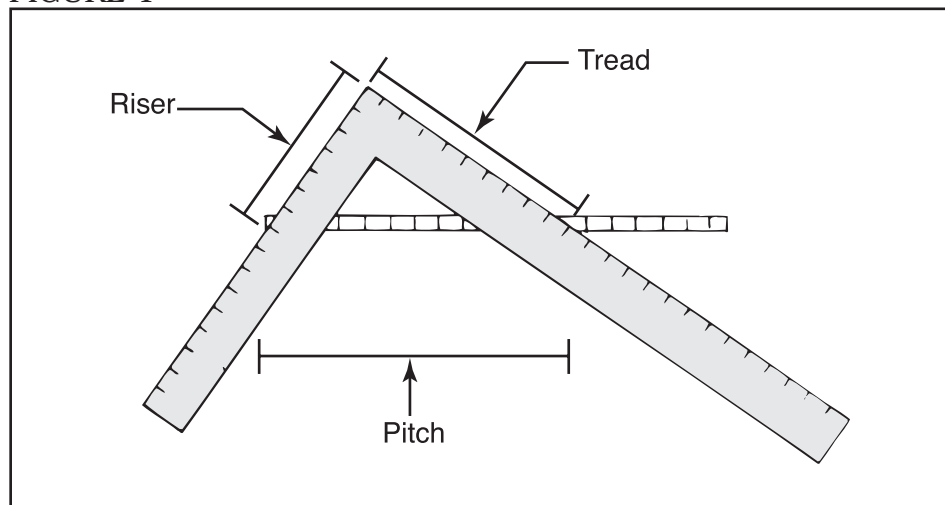

4. Cut form side to size.

✓ **NOTE:** Form sides may also be made from 2 x 6 or wider boards cleated together.

5. Lay out side forms. (Figure 2)



FIGURE 2

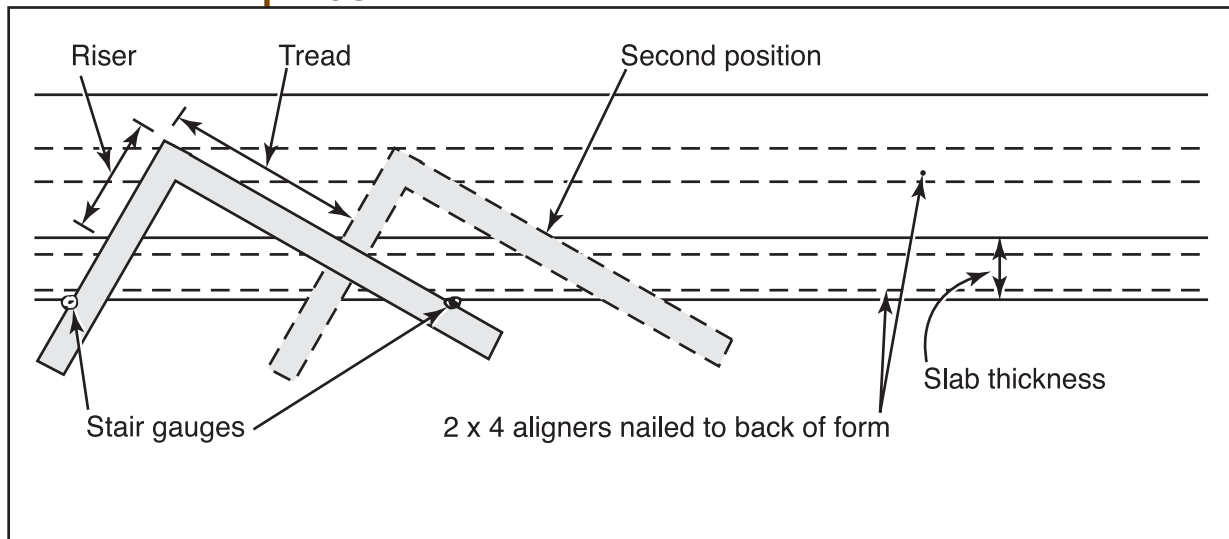

Yes No

- A. Mark a line along the bottom length of the form equal to the slab thickness.
- B. Lay the framing square on the form with riser height and tread width on the slab line.
- C. Attach the stair gauges to the framing square.
- D. Mark the tread and riser on the form.
- E. Move the square to the next step and lay out the tread and riser.
- F. Move the square and mark the form until all the steps are laid out.
- G. Lay out the opposite side of the form, following steps A through F.

✓ **NOTE:** There will be two form sides. The forms will be laid out for right- and left-hand sides.
- H. Nail aligners to the form sides.



Yes No

6. Nail the riser support blocks to the riser form. (Figure 3)

✓ **NOTE:** For a battered riser, add the batter dimension to the tread length as shown on the right-hand riser below.

FIGURE 3

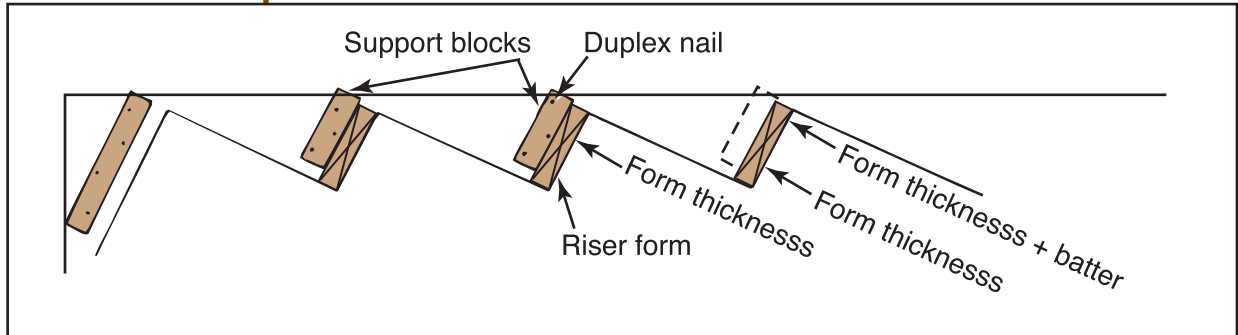

7. Set the grade stakes at the top and bottom of the flight, using a builder's level to establish grade from the bench mark below. (Figure 4)

FIGURE 4

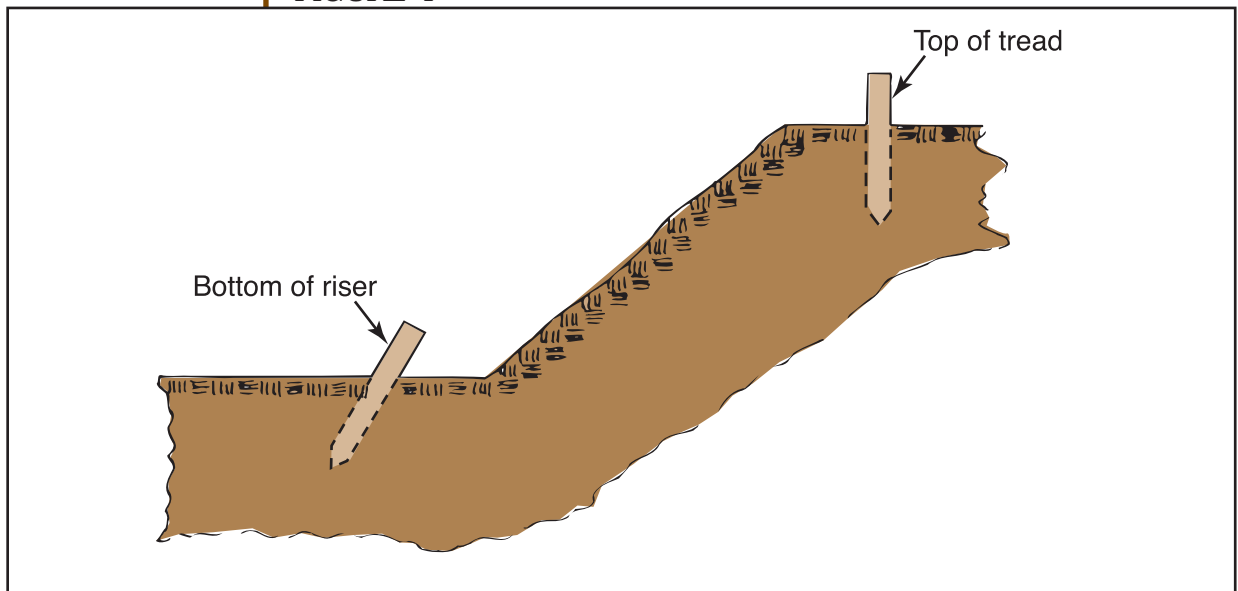

Yes No

8. Drive intermediate stakes.

✓ **NOTE:** Remember to allow for the width of the sheathing and the aligners when driving stakes.

9. Set the form sides.

A. Set the form side against the stakes.

B. Level over from the bottom grade stake to the bottom of the first riser; adjust the form and nail it to the stake.

C. Level over from the top stake to the top tread line; adjust the form and nail it to the stake.

D. Nail the form to the intermediate stakes.

E. Repeat steps A through D to erect the other side.

10. Size the riser forms.

A. Cut the form material to length.

B. Cut the riser forms to width.

C. Cut the bottom of the riser form to a 45-degree angle to facilitate finishing. (Figure 5)

Figure 5

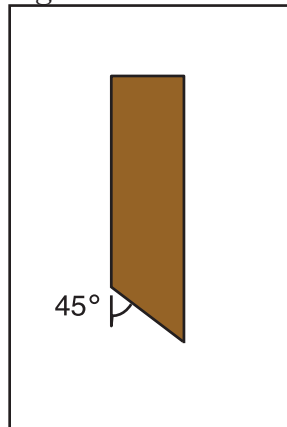

Yes No

- 11. Install the riser forms.
 - A. Place the riser form in position, with the top of the form flush with the tread line and against the block.
 - B. Nail the riser form from the outside of the side form, using duplex nails.
 - C. Repeat steps A and B to continue installation.

✓ **NOTE:** If the bottom landing slab is not poured at this time, a filler piece the thickness of the slab will have to be installed under the bottom riser form.

- 12. Install the bulkhead at the top tread. (Figure 6)

FIGURE 6

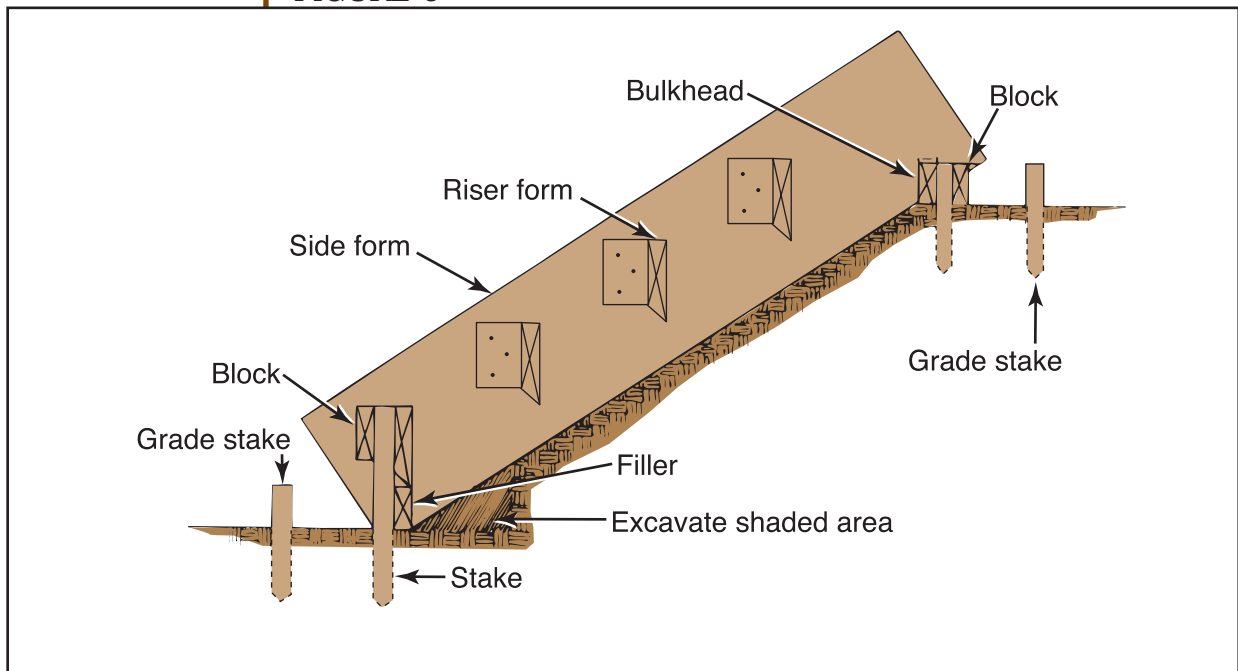

Yes No

13. Install the center support, making sure that the stringer is at least 1 inch above the riser to allow for work room. (Figure 7)

✓ **NOTE:** Center supports are not needed on flights of stairs 4 feet or less in width.

FIGURE 7

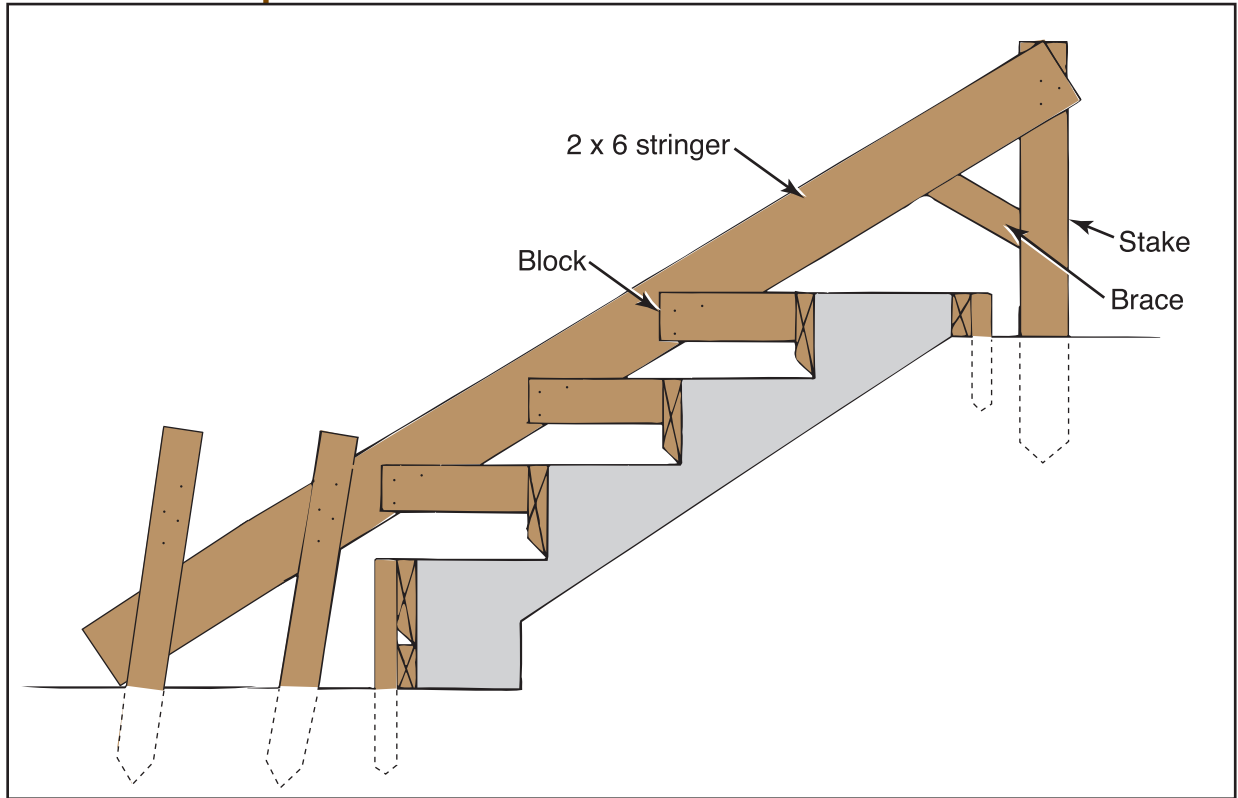

14. Check your work for square and plumb.
15. Have the instructor check your work.
16. Clean the work area and return tools and equipment to proper storage.



SKILL TEST RECORD

PRODUCT EVALUATION

Evaluator note: Rate the student on the following criteria by circling the appropriate numbers. Each criterion must receive a rating of “3” or higher to demonstrate student mastery. (See Key below.) A student who is unable to demonstrate mastery should review the material and submit another product for evaluation.

Criteria:

Safety	4	3	2	1
Layout of risers and treads	4	3	2	1
Formwork	4	3	2	1
Overall performance	4	3	2	1

AVERAGE RATING

Evaluator note: To obtain an average rating for the Profile of Training Mastery, total the points in Product Evaluation and divide by the total number of criteria. Circle the rating on the Key.

KEY

- 4 Skilled** — Can perform job with no additional training
- 3 Moderately Skilled** — Has performed job during training program; limited additional training may be required
- 2 Limited Skill** — Has performed job during training program; additional training is required to develop skill
- 1 Unskilled** — Is familiar with process, but is unable to perform job

EVALUATOR'S COMMENTS



Name _____ Score _____

OBJECTIVE 12

Construct forms for suspended stairs with open sides.

WORDS YOU SHOULD KNOW

pitch board

wood block used as a pattern to lay out steps and to support treads and risers

BASIC SKILLS



Mathematics



Employability

EQUIPMENT AND SUPPLIES

- Claw hammer
- Handsaw
- Power handsaw and extension cord equipped with a ground-fault circuit interrupter



CAUTION: Use eye protection when operating power handsaw.

- Hand level
- Builder's level and rod
- Framing square
- Folding rule or steel tape
- Stair gauges
- Plywood for side forms and decking
- 2 x 4s for stakes, aligners, and blocks
- 1 x 4s for braces
- 4 x 4s for shores, joist, and stringers
- 1½" x 4" x 10' wedges
- 2 x 8s for risers
- Personal protective equipment

✓ **NOTE:** Refer to C.F.R 1926.28 Sub Part C in regard to personal protective equipment.



PROCEDURE

Yes No

- 1. Make a pitch board. (Figure 1)
 - A. Attach stair gauges to the framing square to correspond to the rise and run of a stair unit.
 - B. Place a square on a thin board; make and cut as shown in the figure below.

FIGURE 1

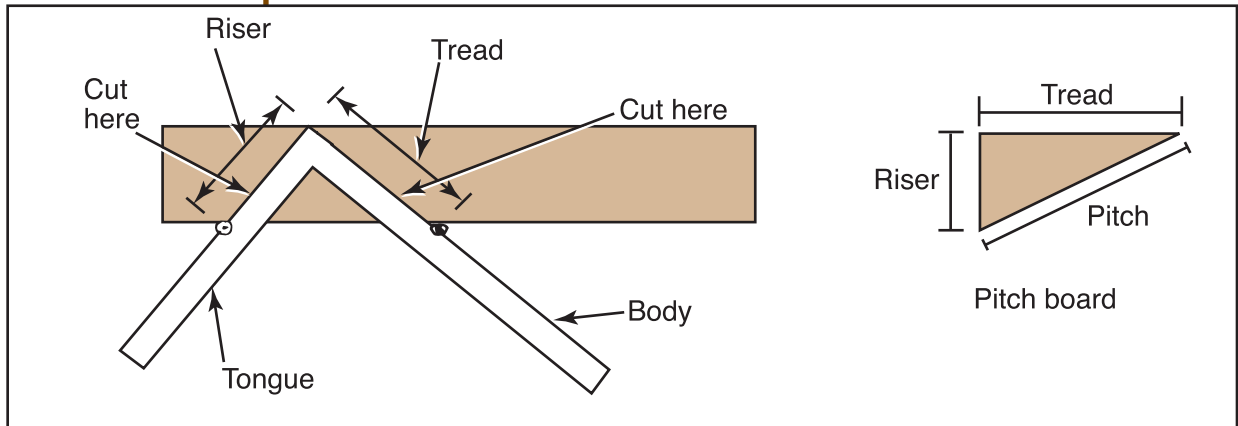

- 2. Cut the form pieces to size. (Figure 2)

FIGURE 2

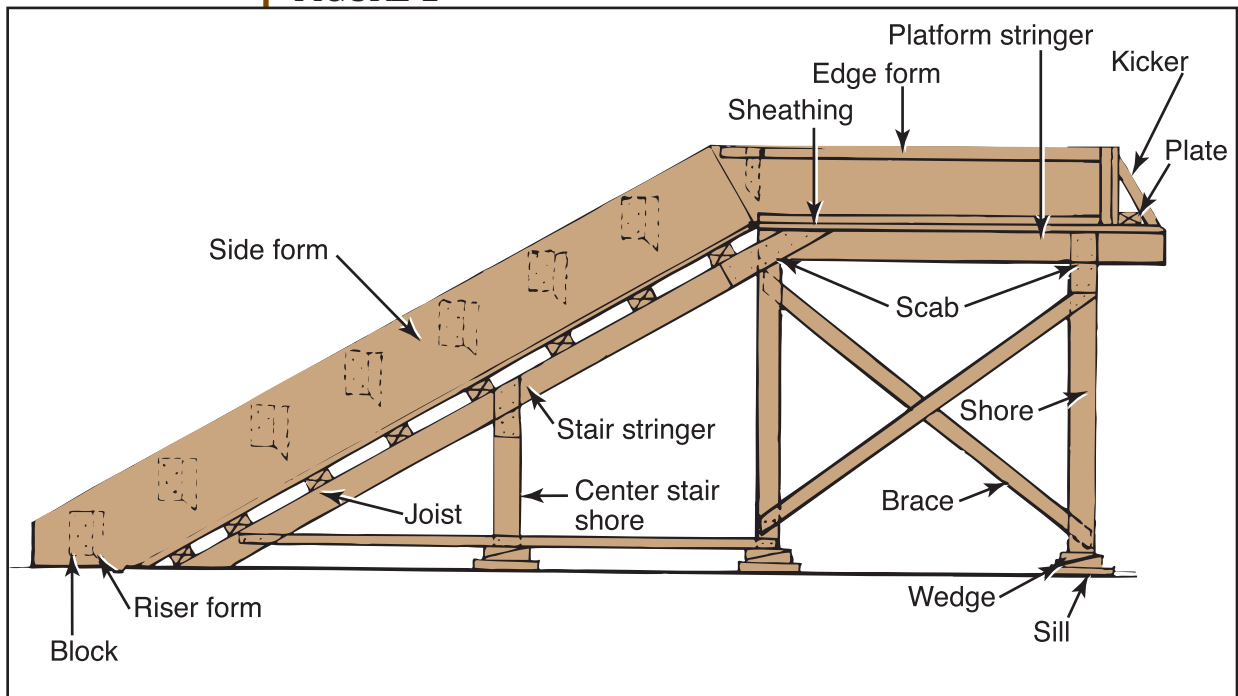

- A. Obtain shore length by subtracting the decking, stringer, sill, and wedge thicknesses from the bottom of the slab height.
- B. Project the stringers past the platform a distance equal to the height of the edge form.
- C. Cut the side forms to width.
 - a. Lay out the pitch board as a guide.
 - b. Measure the step and slab thickness on a line 90 degrees to the pitch.
 - c. Add 2 inches to determine the width at the intersection of the tread and riser.
- D. Frame the side forms.
 - a. Measure the length of the pitch on the pitch board.
 - b. Multiply by the number of treads.
 - c. Add 1 foot to determine the length.
- E. Cut the joist to length by determining the width of slab plus the height of the two side forms.
- F. Cut the edge forms the same width as the slab thickness.
- G. Cut stringer scabs by laying the pitch board on the material with the pitch side flush with the bottom; cut on the tread side.
- H. Cut the stringer blocks by laying the pitch board on the edge of the material with the pitch side flush with the bottom; cut on the riser side.
- I. Size the riser forms.
 - a. Cut to the riser height.
 - b. Cut to the stair width.
 - c. Cut a 45-degree bevel on the bottom edge.

✓ **NOTE:** When pouring a rough stair, it is not necessary to cut the bottom of the riser form at a 45-degree angle. (Figure 3)



FIGURE 3

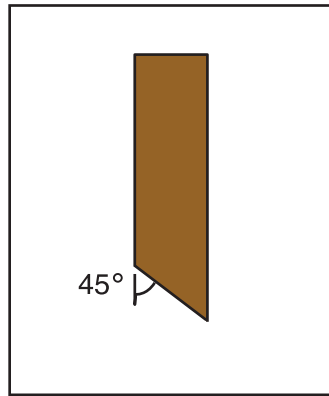

Yes No

3. Lay out the side forms. (Figure 4)

✓ **NOTE:** Two side forms are needed; one right-hand and one left-hand.

FIGURE 4

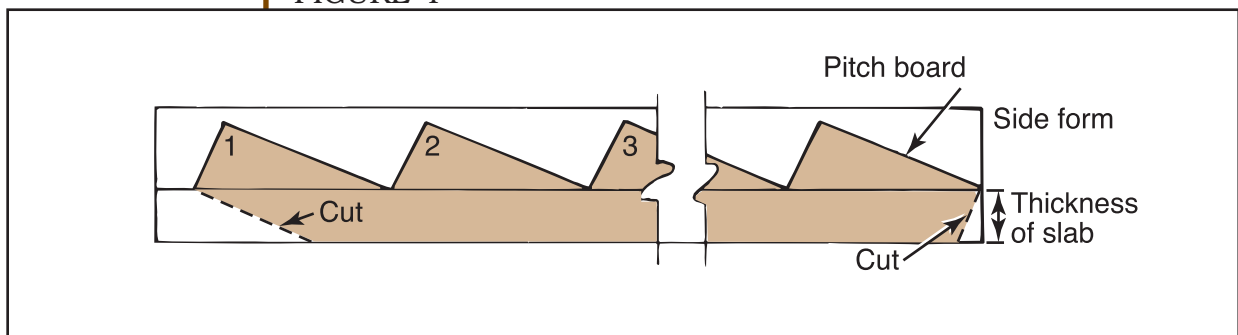

- A. Scribe a pencil line on the form equal to the thickness of the slab.
- B. Lay the pitch side of the the pitch board on the line and mark the tread and riser position #1 as illustrated above, allowing for the thickness of the riser form.
- C. Move the pitch board to position #2 and mark the tread and riser.
- D. Continue moving the pitch board and marking to lay out step #3 and all other steps in the flight.

✓ **NOTE:** Intersect all lines accurately. Use a sharp pencil.



Yes No

E. Use a square to lay out and cut ears as shown by dotted lines in the figure above.

4. Lay out and cut the stringers. (Figure 5)

FIGURE 5

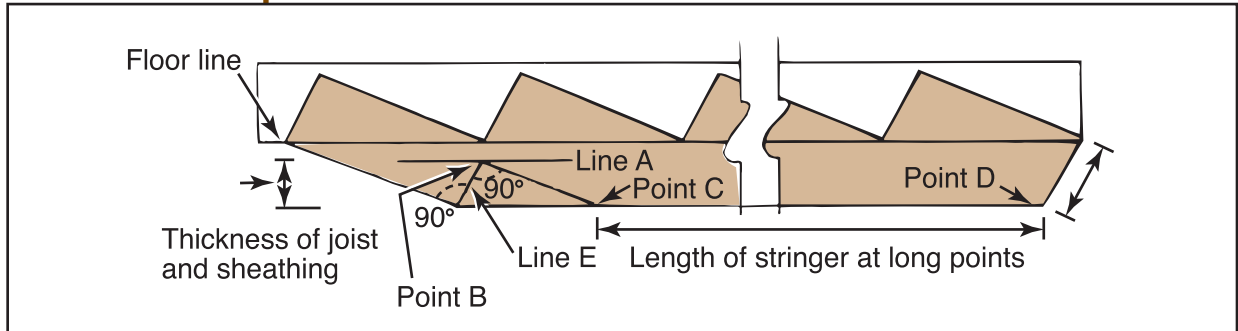

A. Scribe a line equal to the thickness of the joist and sheathing from the lower edge of the side form, establishing "line A."

B. Square from the intersection of the floor line and the bottom of the side form to intersect with "line A" at "point B."

C. Square from "point B" to intersect with the bottom edge of the form at "point C."

D. Measure from "point C" to "point D" to determine the length of the stringer.

E. Lay out this length (the long points) on the stringer.

F. Using the pitch board, lay out the top and bottom cuts as shown below. (Figure 6)

FIGURE 6

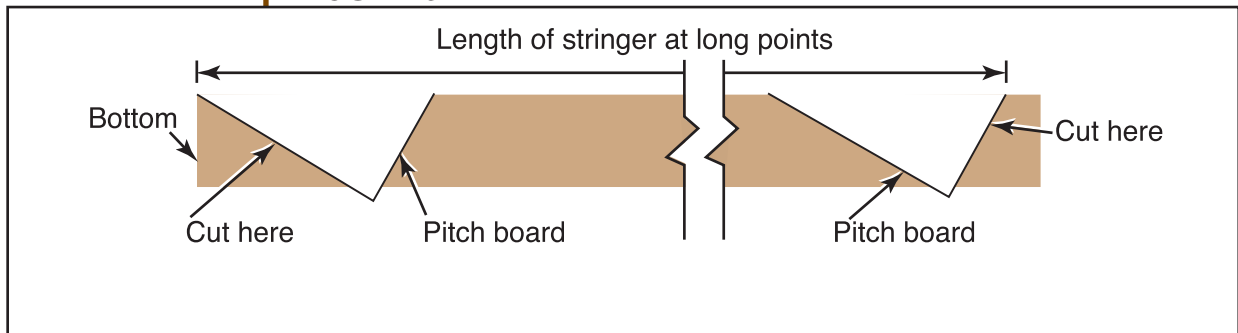

G. Cut on the lines as shown above. (Figure 6)



Yes No

5. Erect the shores and stringers.

A. Nail two shores to each stringer and cross brace as shown below. (Figure 7)

✓ **NOTE:** Place a block the thickness of the shore between braces to nail crossing point.

FIGURE 7

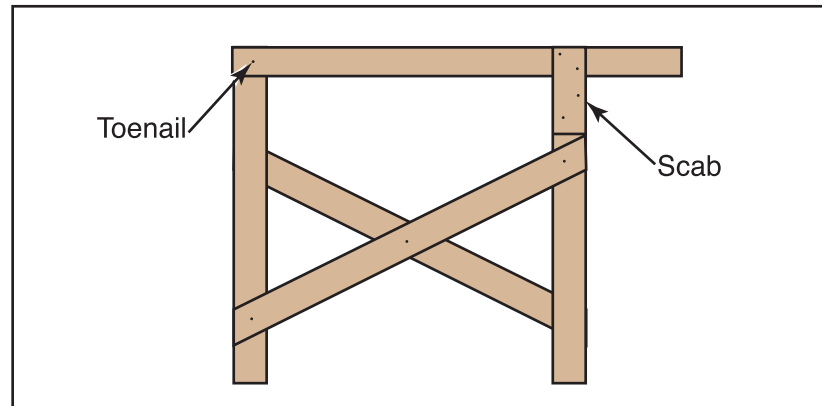

B. Lay the sills on the floor at the location of the shores.

C. Tack wedges to the sills at shore locations.

D. Stand end shores upright; tack spacer board across top; cross brace.

6. Install the stringers.

A. Measure the length of “line E” in Figure 5 from the top of the decking to determine the location of the stringer.

B. Tack the top of the stringer to shore at this location.

C. Nail cleat across the stringer and shore.

D. Repeat steps A through C to complete erection.

7. Nail the joist to the stringers, spacing as needed to allow a uniform overhang on each side.

8. Nail the decking to the joist and stringers, using a minimum of nails to hold decking in place.



Yes No

9. Lay out the sides of the stair and landing, dropping a plumb bob from the edge of stair hole to establish lines.

10. Install the side forms and the edge forms.

✓ **NOTE:** Form oil must be applied before reinforcing bars are installed.

A. Nail a continuous plate to the deck, placing the plate the thickness of the riser forms back from the layout lines.

B. Stand the forms upright on the deck, and nail to the plate.

11. Install the riser form.

A. Hold the riser form on the riser layout line.

B. Nail through the form side with duplex nails.

12. Install the aligner and kick side forms. (Figure 8)

FIGURE 8

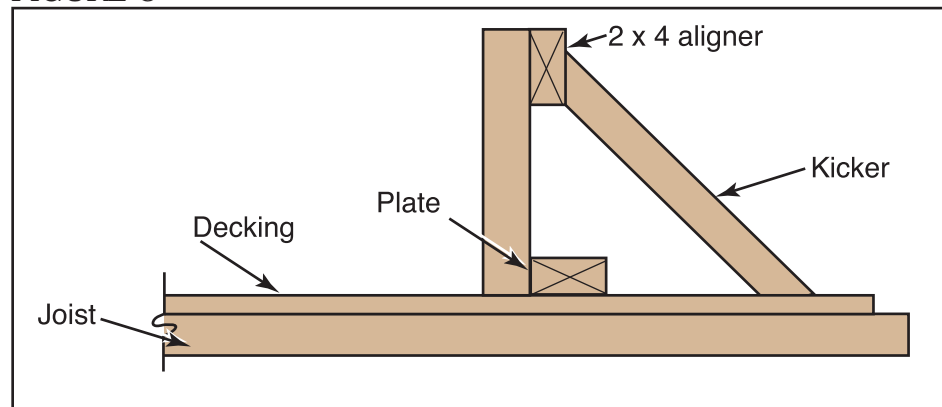

13. Install the blocks at the risers.

✓ **NOTE:** Blocks are not needed if the tread form materials is thick, solid lumber.

14. Check work for square and plumb.

15. Have the instructor check your work.

16. Clean the work area and return tools and equipment to proper storage.



SKILL TEST RECORD

PRODUCT EVALUATION

Evaluator note: Rate the student on the following criteria by circling the appropriate numbers. Each criterion must receive a rating of “3” or higher to demonstrate student mastery. (See Key below.) A student who is unable to demonstrate mastery should review the material and submit another product for evaluation.

Criteria:

Safety	4	3	2	1
Layout of risers and treads	4	3	2	1
Formwork	4	3	2	1
Overall performance	4	3	2	1

AVERAGE RATING

Evaluator note: To obtain an average rating for the Profile of Training Mastery, total the points in Product Evaluation and divide by the total number of criteria. Circle the rating on the Key.

KEY

- 4 Skilled** — Can perform job with no additional training
- 3 Moderately Skilled** — Has performed job during training program; limited additional training may be required
- 2 Limited Skill** — Has performed job during training program; additional training is required to develop skill
- 1 Unskilled** — Is familiar with process, but is unable to perform job

EVALUATOR'S COMMENTS



Name _____ Score _____

OBJECTIVE 13

Place and finish concrete steps with a fine swirl finish.

WORDS YOU SHOULD KNOW

lay down first process of floating concrete after initial set

BASIC SKILLS



Mathematics



Employability

EQUIPMENT AND SUPPLIES

- Hand float
- Hand trowel
- Small trowel
- Margin trowel
- Edger
- Step tools
- Small level (torpedo)
- Cork or rubber float
- Brush or spray bottle
- Claw hammer or nail bar
- Knee pads
- Knee boards
- Sprayer
- Concrete
- Mortar
- Bucket of water
- Curing agent
- Personal protective equipment

✓ **NOTE:** Refer to C.F.R 1926.28 Sub Part C in regard to personal protective equipment.



PROCEDURE

Yes No

1. Begin placing concrete at the top step.
2. Use a square end shovel or margin trowel to spade along inside edge of forms to insure that the face is properly filled.
- ✓ **NOTE:** Be sure each step is well vibrated, tapping each step with a hammer. Do not overvibrate because this could force the movement of forms.
3. Float the surfaces of the steps until they are relatively smooth and on grade.
- ✓ **NOTE:** All excess concrete should be placed in the step below.
4. Clean the top and the faces of the forms to ensure a clean final finish.
5. Continue filling and floating the steps, working downward until all steps have been filled and laid down.
- ✓ **NOTE:** It may be necessary to float the steps more than once before the final finish.
6. Place knee boards, if applicable, on steps three and four from top when the concrete is hard enough.
7. Kneel on the top board for balance and float the top step until it is relatively smooth and to grade.
8. Use a level to check the step to ensure that it has proper fall. (Figure 1)



FIGURE 1

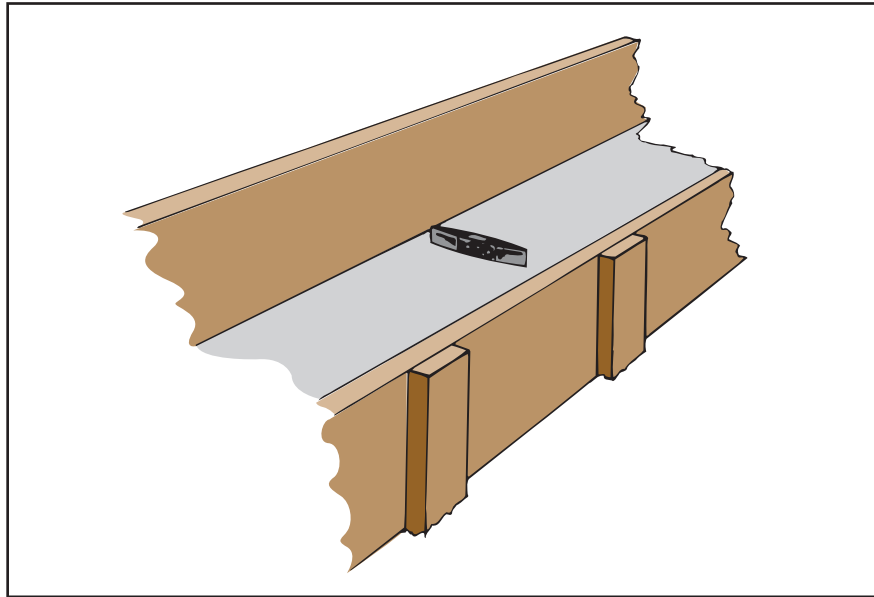

Yes No

9. Tilt the edger slightly up and move the edger forward along the inside of the form; then with the edger tilted up, move the edger backward until the edge is rounded and smooth. (Figure 2)

FIGURE 2

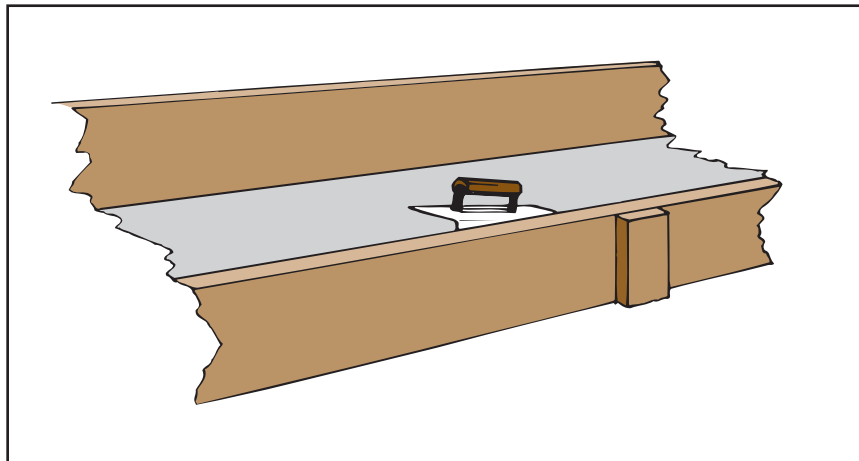

10. Hold the trowel relatively flat to the surface and trowel the top step.

✓ **NOTE:** Sometimes forms are built so that it is hard to trowel corners. If this is so, use a pipe trowel, corner tool, or the appropriate edger to work out the corners.

11. Move the knee boards down one step and repeat steps 7 through 10 on the second step.



Yes No

12. Continue these procedures until all the steps have been troweled a first time.

✓ **NOTE:** If landings are poured with the steps, follow the same floating and troweling procedures as you move down the flight of steps. It may be necessary for a time period to elapse before starting to remove the riser boards.

13. Use a claw hammer or a nail bar to pull the nails from the top riser board and remove the board.

✓ **NOTE:** Remove as many unnecessary nails as possible before the riser boards are ready to be removed.

14. Remove the riser boards. (Figure 3)

A. Strike the board on both ends with a hammer.

B. On one end of the riser, use the claw of the hammer to pry the riser board up.

C. Proceed to the opposite side and repeat step B.

D. Slide the riser board up keeping it parallel to the face of the step.

FIGURE 3

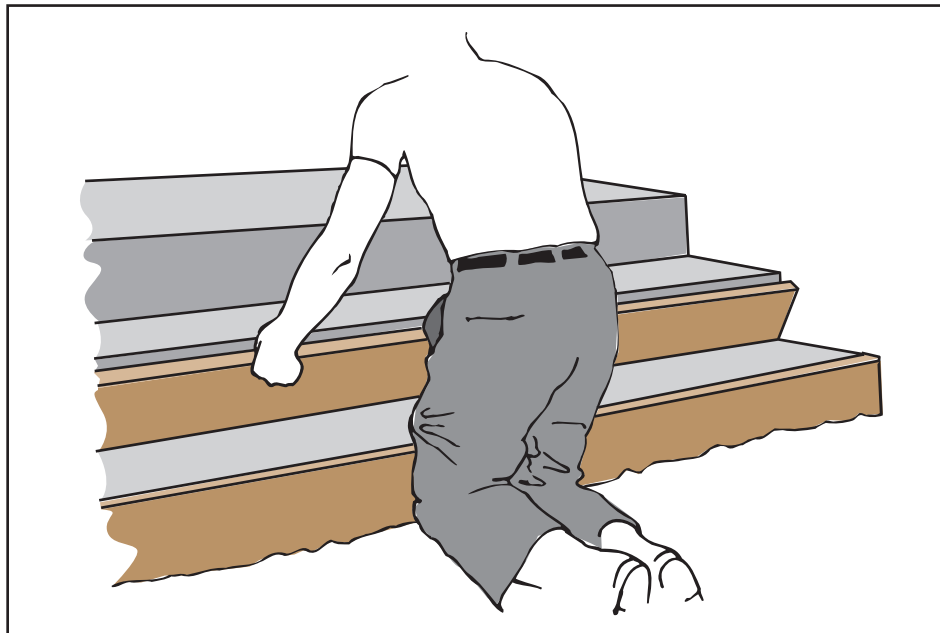

Yes No

- 15. Dampen the face of the riser slightly with a wet brush or spray bottle when necessary.
- 16. Use a float or trowel in a circular motion, just enough so that the riser will be smooth. (Figure 4)

FIGURE 4



- 17. Use the inside step tool and move it back and forth along the cove until it's smooth. (Figure 5)

FIGURE 5

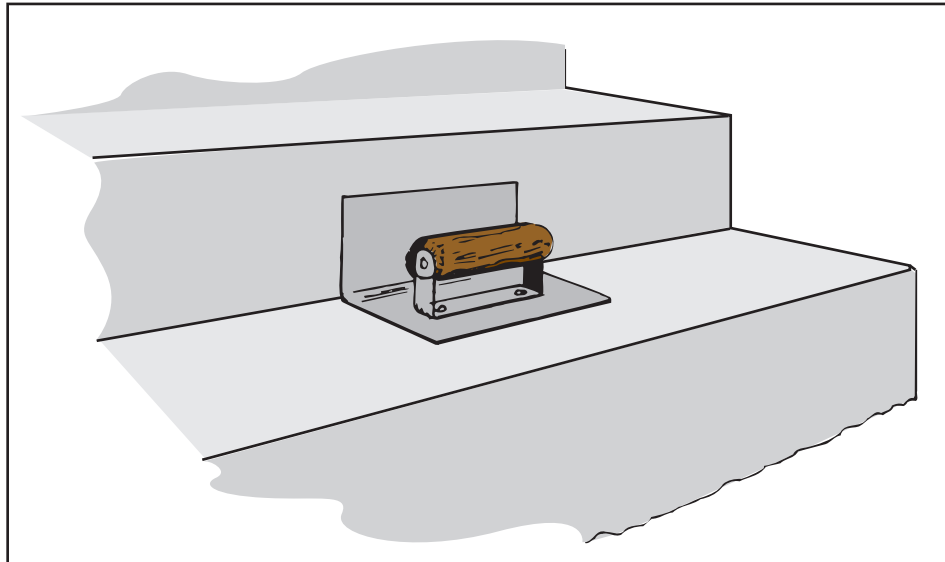

- 18. Use the outside step tool in a back and forth motion to smooth the top edge of the riser. (Figure 6)



FIGURE 6

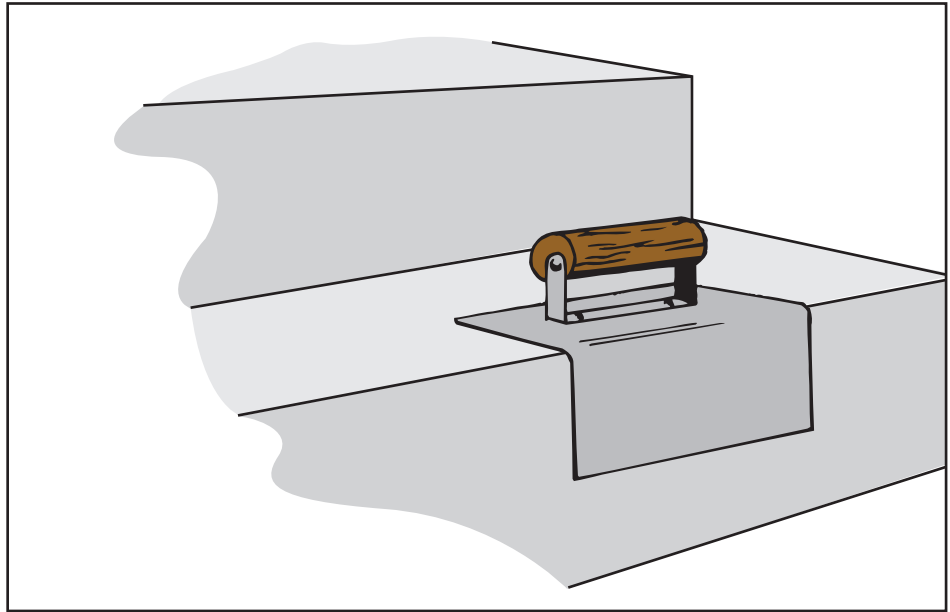

✓ **NOTE:** Step tools may be referred to as nose and cove tool.

Yes No

- 19. Use a small trowel to trowel the face of the riser in a back and forth motion until the surface is smooth.
- 20. Use a damp brush to brush the face of the riser very lightly back and forth to obtain a fine-textured finish.
- 21. Move the trowel in a semicircular fan-like motion on the tread, keeping the trowel flat to the surface.

✓ **NOTE:** This will leave a fine, fuzzy, fan-like pattern.

- 22. Move the knee boards down one step and repeat the same procedures until all the steps have been completed.
- 23. Apply a curing agent using a sprayer with the nozzle adjusted to a fine mist.
- 24. Use the margin trowel, brush, and water to clean tools and equipment.
- 25. Have the instructor check your work.
- 26. Clean the work area and return tools and equipment to proper storage.



SKILL TEST RECORD

PRODUCT EVALUATION

Evaluator note: Rate the student on the following criteria by circling the appropriate numbers. Each criterion must receive a rating of “3” or higher to demonstrate student mastery. (See Key below.) A student who is unable to demonstrate mastery should review the material and submit another product for evaluation.

Criteria:

Safety	4	3	2	1
Layout of risers and treads	4	3	2	1
Formwork	4	3	2	1
Overall performance	4	3	2	1

AVERAGE RATING

Evaluator note: To obtain an average rating for the Profile of Training Mastery, total the points in Product Evaluation and divide by the total number of criteria. Circle the rating on the Key.

KEY

- 4 Skilled** — Can perform job with no additional training
- 3 Moderately Skilled** — Has performed job during training program; limited additional training may be required
- 2 Limited Skill** — Has performed job during training program; additional training is required to develop skill
- 1 Unskilled** — Is familiar with process, but is unable to perform job

EVALUATOR'S COMMENTS





Name _____ Score _____

OBJECTIVE 14

Place and finish concrete steps in metal pan forms with a nonskid finish.

BASIC SKILLS



Employability

**EQUIPMENT
AND SUPPLIES**

- Hand float
- Hand trowel
- Margin trowel
- Small level (torpedo)
- Knee boards
- Knee pads
- Gauge
- Brush
- Spray bottle with water/soap mixture
- Concrete
- Abrasive grits
- Bucket of water
- Curing agent
- Personal protective equipment

✓ **NOTE:** Refer to C.F.R 1926.28 Sub Part C in regard to personal protective equipment.

PROCEDURE

Yes No

1. Start placing at the top step.

✓ **NOTE:** Concrete in most pan steps is 2" to 2½" thick. Use a gauge to ensure proper depth and levelness. A form release or bond breaker, such as a spray bottle filled with a high concentration of soap and water, should be applied to exposed surfaces prior to placing. (Figure 1)



FIGURE 1

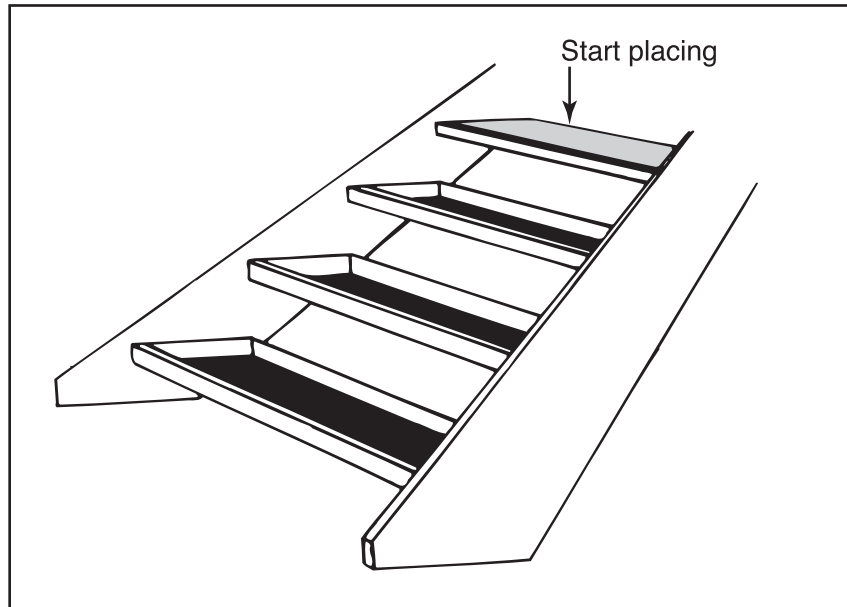

Yes No

2. Float the surface of the top step until it is relatively smooth and on grade.

✓ **NOTE:** The back corner of the tread should be flat and level. All excess concrete should be moved down to the next step, cleaning the metal as you go.

3. Move down and continue filling and floating the steps until all have been filled and leveled.

✓ **NOTE:** It may be necessary for a time period to elapse before proceeding with the next step.

4. Place knee boards on steps three and four from the top when the concrete is hard enough.

5. Kneel on the top board for balance and float the top step until it is relatively smooth and to grade.

6. Use a level to check the step to insure that it has proper fall. (Figure 2)



FIGURE 2

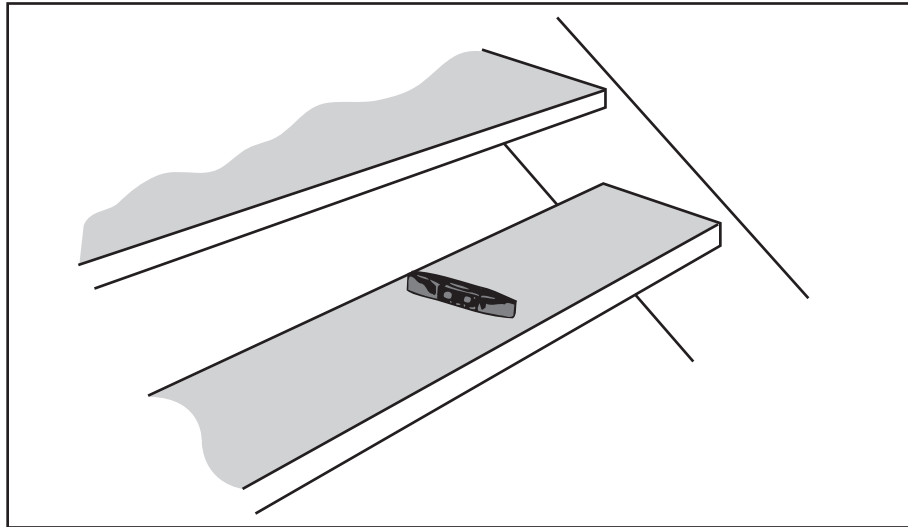

Yes No

- 7. Hold trowel relatively flat to the surface and trowel the top step.
- 8. Move the knee boards down one step and continue the same procedure until all the steps have been troweled the first time.

✓ **NOTE:** If landings are poured with the steps, follow the same floating and troweling procedures as you move down the flight of steps. It may be necessary for a time period to elapse before starting the next steps.

- 9. Use your hands to sprinkle the abrasive grits evenly over surface of steps, providing the concrete is hard enough. (Figure 3)



FIGURE 3

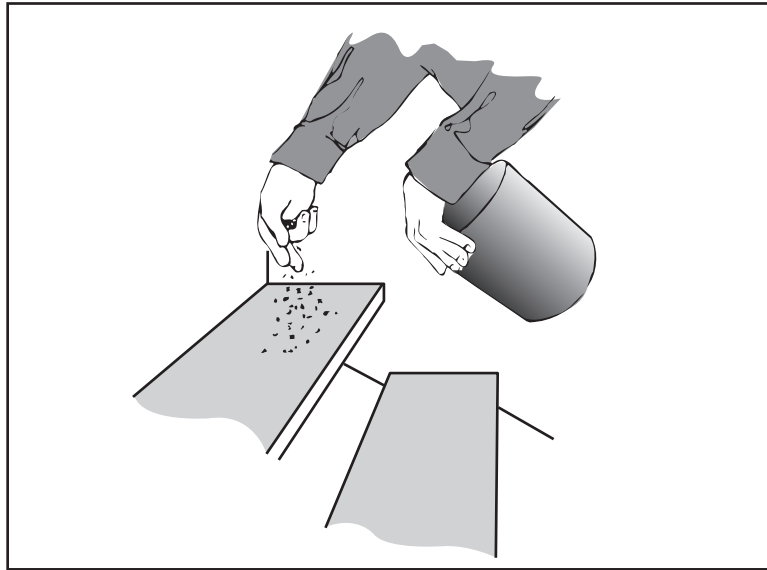

Yes No

10. Place the knee boards on steps three and four and again trowel the steps, working the grits into the surface.

✓ **NOTE:** Do not overwork. The grits should be worked just barely into the surface to create a nonskid finish, whether it be a primary or secondary traction base.

11. Trowel the surface in a semicircular fan-like motion, keeping the trowel flat to the surface to obtain the desired finish. (Figure 4)

✓ **NOTE:** This will leave a fine, fuzzy, fan-like pattern.



FIGURE 4

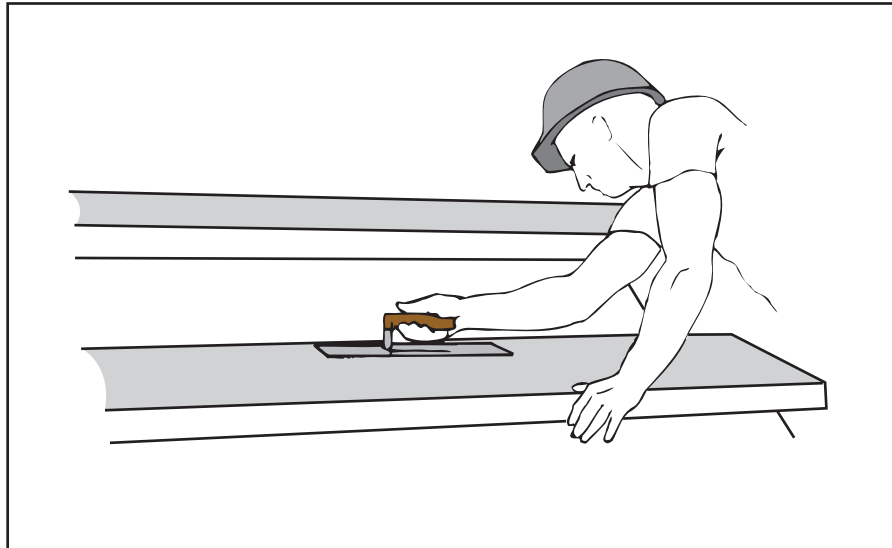

Yes No

- 12. Move the knee boards down one step and continue the same procedure until the steps have been completed.
- 13. Apply the appropriate curing agent, using a sprayer with the nozzle adjusted to a fine mist.
- 14. Use a margin trowel, brush, and water to clean the tools, equipment, and exposed metal surfaces on the steps.
- 15. Have the instructor check your work.
- 16. Clean the work area and return tools and equipment to proper storage.



SKILL TEST RECORD

PRODUCT EVALUATION

Evaluator note: Rate the student on the following criteria by circling the appropriate numbers. Each criterion must receive a rating of “3” or higher to demonstrate student mastery. (See Key below.) A student who is unable to demonstrate mastery should review the material and submit another product for evaluation.

Criteria:

Safety	4	3	2	1
Neatness and appearance	4	3	2	1
Use of tools	4	3	2	1
Overall performance	4	3	2	1

AVERAGE RATING

Evaluator note: To obtain an average rating for the Profile of Training Mastery, total the points in Product Evaluation and divide by the total number of criteria. Circle the rating on the Key.

KEY

- 4 Skilled** — Can perform job with no additional training
- 3 Moderately Skilled** — Has performed job during training program; limited additional training may be required
- 2 Limited Skill** — Has performed job during training program; additional training is required to develop skill
- 1 Unskilled** — Is familiar with process, but is unable to perform job

EVALUATOR'S COMMENTS



Name _____ Score _____

OBJECTIVE 15

Place and finish concrete steps with nosings and pipe inserts.

WORDS YOU SHOULD KNOW

pipe insert tubular piece of metal inserted into concrete into which stair railing are anchored

BASIC SKILLS



Employability

EQUIPMENT
AND SUPPLIES

- Float
- Trowel
- Small trowel
- Margin trowel
- Small level (torpedo)
- Hammer
- Brush
- Knee pads
- Knee boards
- Rule
- Edger
- Concrete
- Nosings
- Duct tape
- Bucket of water
- Pipe inserts
- Curing agent and sprayer
- Personal protective equipment

✓ **NOTE:** Refer to C.F.R 1926.28 Sub Part C in regard to personal protective equipment.



PROCEDURE

Yes No

1. Start the pour at the top step.
- ✓ **NOTE:** Be sure each step is well vibrated. Do not overvibrate. Tapping each step with a hammer could force the movement of forms.
2. Use a margin trowel or squarehead shovel to spade along the inside edge of the forms to insure that the face is properly filled.
3. Float the surfaces of the steps until they are relatively smooth and on grade.
4. Clean the top and face of the riser forms to ensure a clean final finish.
- ✓ **NOTE:** All excess concrete should be placed on the step below.
5. Continue filling and floating the steps, working down until all steps have been filled and leveled.
- ✓ **NOTE:** It may be necessary to float steps more than once.
6. Place knee boards, if applicable, on steps three and four from the top, providing concrete is hard enough.
7. Kneel on the top board for balance and float the top step until it is relatively smooth and to grade.
8. Use a rule to lay out and mark the tread so nosing will center on the step.
9. Use a margin trowel to cut along the front edge of the form.
10. Place the nosing on the step with front edge tight to the form and, using a hammer and/or block of wood, tap the nosing down until it is flush with the top of the form.
- ✓ **NOTE:** Nosing should be covered with duct tape prior to installation.



Yes No

- 11. Use a margin trowel to consolidate the concrete under the nosing to be sure voids around anchors have been sealed properly and that the concrete is worked around the anchors.
- 12. Lay out and mark the location of the pipe insert.
- 13. Use a margin trowel to dig a hole in the concrete at the location of the insert.
- 14. Place the insert in the hole and tap lightly until the insert is on grade in the proper location.
- 15. Work the concrete around the insert until it is properly seated.
- 16. Float the step until it is smooth and on grade.
- 17. Use a level to check the step to ensure that it has the proper fall. (Figure 1)

FIGURE 1

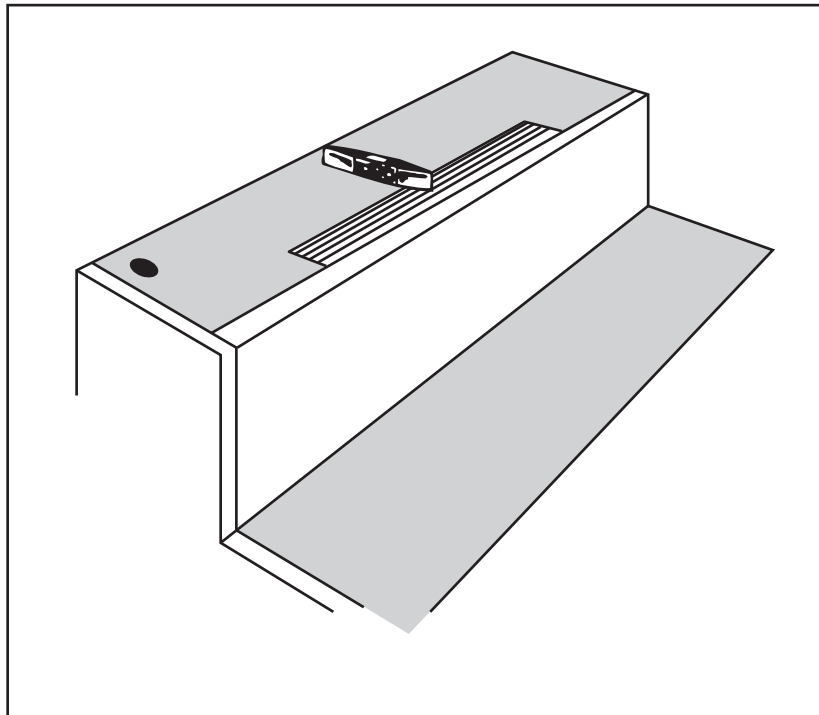

Yes No

18. Tilt the edger slightly up and edge the remaining section of the step. (Figure 2)

FIGURE 2

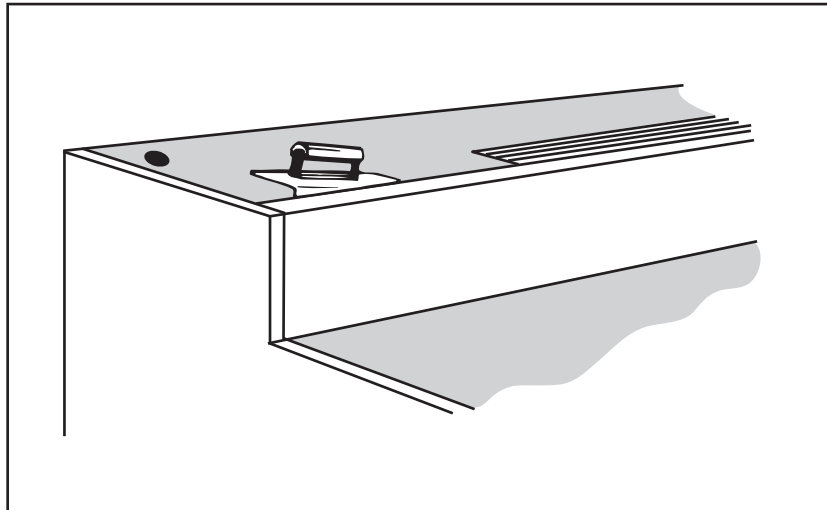

19. Hold the trowel relatively flat to the surface and trowel the top step.

✓ **NOTE:** Sometimes forms are built so that it is hard to trowel the corners; if this is so, use a pipe trowel, margin trowel, corner, or appropriate tool to work out the corners.

20. Move the knee boards down one step and continue the same procedure on the second step.

✓ **NOTE:** Inserts will not be used on every step. Therefore, repeat those steps only when necessary.

21. Continue procedures until all nosings are in and the steps have been troweled the first time.

✓ **NOTE:** If landings are poured with the steps, follow the same floating and troweling procedures as you move down the flight of stairs.

22. Start at the top step and repeat the troweling procedures, this time holding trowel flat to the surface.



Yes No

- 23. Continue this procedure until the steps are completed.
- 24. Apply the appropriate curing agent, using a sprayer with the nozzle adjusted to a fine mist.
- 25. Use a margin trowel, brush, and water to clean tools and equipment.

✓ **NOTE:** To keep from loosening the nosings, the riser forms will not be removed at this time. They will be removed after concrete has hardened. Risers will be rubbed and finished.

- 26. Have the instructor check your work.
- 27. Clean the work area and return tools and equipment to proper storage.



SKILL TEST RECORD

PRODUCT EVALUATION

Evaluator note: Rate the student on the following criteria by circling the appropriate numbers. Each criterion must receive a rating of “3” or higher to demonstrate student mastery. (See Key below.) A student who is unable to demonstrate mastery should review the material and submit another product for evaluation.

Criteria:

Safety	4	3	2	1
Use of tools	4	3	2	1
Tread installation	4	3	2	1
General appearance	4	3	2	1
Overall performance	4	3	2	1

AVERAGE RATING

Evaluator note: To obtain an average rating for the Profile of Training Mastery, total the points in Product Evaluation and divide by the total number of criteria. Circle the rating on the Key.

KEY

- 4 Skilled** — Can perform job with no additional training
- 3 Moderately Skilled** — Has performed job during training program; limited additional training may be required
- 2 Limited Skill** — Has performed job during training program; additional training is required to develop skill
- 1 Unskilled** — Is familiar with process, but is unable to perform job

EVALUATOR'S COMMENTS

