

**INTRODUCTION**

Proper planning prior to starting a concrete job will help prevent wasted materials and effort. There are several ways you can estimate the cubic yards of concrete needed for a job, the number of rolls of welded wire fabric, the lineal feet of form lumber, and the number of form stakes needed for a job. These estimates will help you get an idea of what supplies you will need before you begin a project.

**FOCUS ASSIGNMENTS**

**FOCUS ASSIGNMENTS**

1. Use an electronic concrete calculator to find the volume of 5 pillars that are 5 feet in diameter and 10 feet tall.

[circ] — shows \_\_\_\_\_ sq. feet area; multiply by 10 = \_\_\_\_\_ cu. feet. Multiply by 5 = \_\_\_\_\_. How many cubic yards is this?

[conv] [yds] = \_\_\_\_\_



Reading



Mathematics



Employability



Technology

**UNIT OBJECTIVE**

After completing this unit, you will show the following competencies by mastering the activities on the Assignment Sheet and by scoring at least 85% on the Written Test.

**SPECIFIC OBJECTIVES**

1. List methods used to estimate cubic yards of concrete needed for a job.
2. Use a concrete calculator to estimate cubic yards of concrete needed for a job.
3. Use a concrete estimating table to estimate cubic yards of concrete needed for a job.
4. Use the formula for estimating cubic yards of concrete needed for a job.
5. List standard mesh and wire sizes of welded wire fabric.
6. Estimate rolls of welded wire fabric needed for a job.



7. Estimate lineal feet of form lumber needed for a job.
8. Estimate number of form stakes needed for a job.
9. Estimate the materials needed for a concrete job. (Assignment Sheet)



**OBJECTIVE 1**

Required Activities/  
Resources  
— Transparencies 1-3

Optional Activities/  
Resources in Instructor's  
Guide

**List methods used to estimate cubic yards of concrete needed for a job.**



Your instructor will show you transparencies of concrete estimating tools.

**WORDS YOU SHOULD KNOW**

<b>estimating</b>	determining the approximate amount of a substance or material needed for a job
<b>formula</b>	group of symbols used to express a mathematical concept

- Concrete calculator
- Concrete estimating table
- Formula for estimating concrete

✓ **NOTE:** Use the formula to estimate concrete when using pencil and paper or when using an electronic calculator.

**OBJECTIVE 2**

Optional Activities/  
Resources in Instructor's  
Guide

**Use a concrete calculator to estimate cubic yards of concrete needed for a job.**

**WORDS YOU SHOULD KNOW**

<b>cubic yard</b>	3' x 3' x 3', or 27 cubic feet; unit of measure used for ordering concrete
-------------------	--

1. Locate the required thickness on Scale A of the concrete calculator.
2. Locate the required width (or height) on Scale B of the concrete calculator.
3. Move the center portion of the calculator to align the required length of Scale A with the required width (or height) on Scale B.
4. Locate the required length on Scale C of the concrete calculator.



5. Read the number on Scale D that aligns with the required length on Scale C to find the cubic yards of concrete needed for a job.

**EXAMPLE:** If you are to pour a concrete slab that will be 4 inches thick by 40 feet wide by 40 feet long, then:

- A. Locate the 4-inch thickness on Scale A (Figure 1)
- B. Locate the 40-foot width on Scale B (Figure 1)
- C. Move the center portion of the calculator to align the 4-inch mark on Scale A with the 40-foot mark on Scale B (Figure 1)
- D. Locate the 40-foot length on Scale C (Figure 1)
- E. Read the number on Scale D that aligns with the 40-foot length mark to find the cubic yards on the concrete needed for the job —  $19\frac{3}{4}$  cubic yards (Figure 1)

FIGURE 1

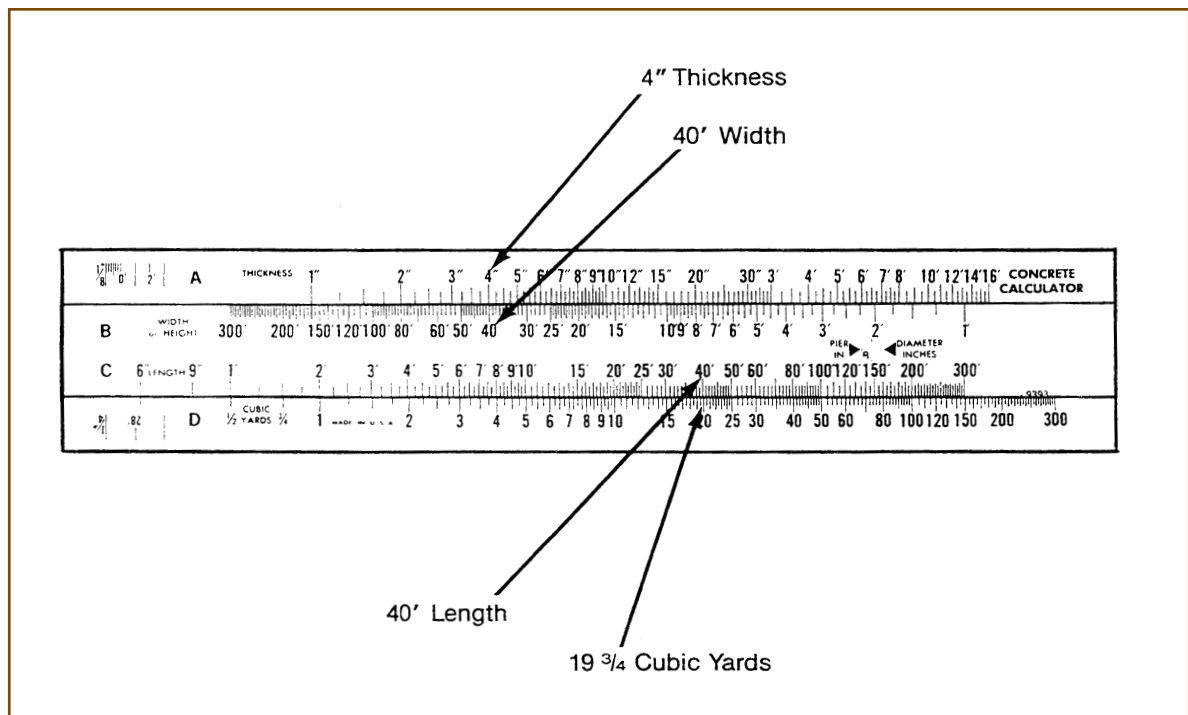

### OBJECTIVE 3

Optional Activities/  
Resources in Instructor's  
Guide

**Use a concrete estimating table to estimate cubic yards of concrete needed for a job.**

1. Determine the required area of a job by multiplying the length by the width, using the formula:

$$\text{Area} = \text{Length} \times \text{Width}$$

**EXAMPLE:** If you are to pour a slab that will be 80 feet long by 40 feet wide by 4 inches thick, then:

$$\text{Area} = 80' \times 40' = 3200 \text{ Square feet}$$

2. Locate the required thickness on the thickness column of the concrete estimating table. (Figure 2)

**EXAMPLE:** Locate 4 inches on the thickness column of the concrete estimating table.

FIGURE 2

One cubic yard of concrete will place					
Thickness	Sq ft	Thickness	Sq ft	Thickness	Sq ft
1" . . . . .	324	5" . . . . .	65	9" . . . . .	36
1 1/4" . . . . .	259	5 1/4" . . . . .	62	9 1/4" . . . . .	35
1 1/2" . . . . .	216	5 1/2" . . . . .	59	9 1/2" . . . . .	34
1 3/4" . . . . .	185	5 3/4" . . . . .	56	9 3/4" . . . . .	33
2" . . . . .	162	6" . . . . .	54	10" . . . . .	32.5
2 1/4" . . . . .	144	6 1/4" . . . . .	52	10 1/4" . . . . .	31.5
2 1/2" . . . . .	130	6 1/2" . . . . .	50	10 1/2" . . . . .	31
2 3/4" . . . . .	118	6 3/4" . . . . .	48	10 3/4" . . . . .	30
3" . . . . .	108	7" . . . . .	46	11" . . . . .	29.5
3 1/4" . . . . .	100	7 1/4" . . . . .	45	11 1/4" . . . . .	29
3 1/2" . . . . .	93	7 1/2" . . . . .	43	11 1/2" . . . . .	28
3 3/4" . . . . .	86	7 3/4" . . . . .	42	11 3/4" . . . . .	27.5
4" . . . . .	81	8" . . . . .	40	12" . . . . .	27
4 1/4" . . . . .	76	8 1/4" . . . . .	39	15" . . . . .	21.5
4 1/2" . . . . .	72	8 1/2" . . . . .	38	18" . . . . .	18
4 3/4" . . . . .	68	8 3/4" . . . . .	37	24" . . . . .	13.5

81 Sq Ft

4" Thickness

3. Read across the table to determine the square feet (area) 1 cubic yard of concrete will cover at the required thickness. (Figure 2)

**EXAMPLE:** One cubic yard of concrete will cover 81 square feet at 4-inch thickness.



4. Divide the square-foot amount from the table into the number of square feet in the job to find the cubic yards of concrete needed for the job, using the formula:

$$\text{Cubic Yards of Concrete Needed for Job} = \frac{\text{Area of Job (Square Feet)}}{\text{Square-Foot Number from Estimating Table}}$$

EXAMPLE: If the area of the job is 3200 square feet and the square-foot number from the concrete estimating table is 81, then:

$$\text{Cubic Yards of Concrete Needed for Job} = \frac{3200 \text{ Square Feet}}{81 \text{ Square Feet}} = 39 \frac{1}{2}$$

## OBJECTIVE 4

Optional Activities/  
Resources in Instructor's  
Guide

### Use the formula for estimating cubic yards of concrete needed for a job.

1. Determine the length, width, and thickness of the job.

EXAMPLE: Assume you are to pour a concrete slab that will be 60 feet long by 30 feet wide by 3 inches thick.

2. If the thickness of the job is in inches, convert this amount to a fraction of a foot or a decimal portion of a foot.

✓ **NOTE:** Thicknesses are usually quoted in inches.

EXAMPLE: If the slab is to be 3 inches thick, convert 3 inches into  $\frac{1}{4}$  foot, or .25 foot.

3. Determine the cubic yards of concrete needed for the job by multiplying the length of the job (in feet) by the width of the job (in feet) by the thickness of the job (in feet) and dividing the product by 27, using the formula:

$$\text{Cubic Yards of Concrete Needed for Job} = \frac{\text{Length in Ft} \times \text{Width in Ft} \times \text{Thickness in Ft}}{27}$$

EXAMPLE: If you are to pour a concrete slab that will be 60 feet long by 30 feet wide by 3 inches thick, then:

$$\text{Cubic Yards of Concrete Needed for Job} = \frac{60' \times 30' \times .25'}{27} = \frac{450}{27} = 16.66$$



## OBJECTIVE 5

Required Activities/  
Resources  
— Transparency 4

Optional Activities/  
Resources in Instructor's  
Guide

### List standard mesh and wire sizes of welded wire fabric.



Your instructor will show you a transparency showing standard mesh and wire sizes of welded wire fabric.

- 6" x 6" mesh size — W2.9 x W2.9 wire size 6 gauge
- 6" x 6" mesh size — W2.0 x W2.0 wire size 8 gauge
- 6" x 6" mesh size — W1.4 x W1.4 wire size 10 gauge
- 4" x 4" mesh size — W1.4 x W1.4 wire size 10 gauge
- Standard size of welded-wire-fabric rolls — 5-7 feet width and up to 200 feet in length.

## OBJECTIVE 6

Optional Activities/  
Resources in Instructor's  
Guide

### Estimate rolls of welded wire fabric needed for a job.

1. Determine the area of the job by multiplying the length by the width, using the formula:

$$\text{Area} = \text{Length} \times \text{Width}$$

EXAMPLE: If the job is to be 100 feet long by 50 feet wide, then:

$$\text{Area} = 100' \times 50' = 5000 \text{ Square Feet}$$

2. Divide the area of the job by 675 to determine the number of rolls of welded wire fabric needed for the job, using the formula:

$$\text{Rolls of Welded Wire Fabric Needed for Job} = \frac{\text{Area}}{675}$$

✓ **NOTE:** The number 675 is a constant representing the square feet of coverage in a standard 5' x 150' roll of welded wire fabric installed with a 6-inch overlay for each row.

EXAMPLE: If the area of a job is 5000 square feet, then:

$$\text{Rolls of Welded Wire Fabric Needed for Job} = \frac{5000 \text{ Square Feet}}{675} = 7.40$$



## OBJECTIVE 7

Optional Activities/  
Resources in Instructor's  
Guide

### Estimate lineal feet of form lumber needed for a job.

Measure the distance in which lumber will be used.

#### WORDS YOU SHOULD KNOW

**lineal measurement** unit of measure in a straight line

✓ **NOTE:** Lumber is sold in even-foot measurements (6 feet, 8 feet, 10 feet, 12 feet). Most supplies mix lengths to get as close as possible for the amount ordered if each length is not specified. The buyer is charged for the amount delivered, not for the amount ordered.

**EXAMPLE:** If you must estimate the lumber needed for the form to be built for the slab in Figure 3, you would measure the perimeter of the area and add these measurements to find that you would need 88 lineal feet of lumber.

FIGURE 3

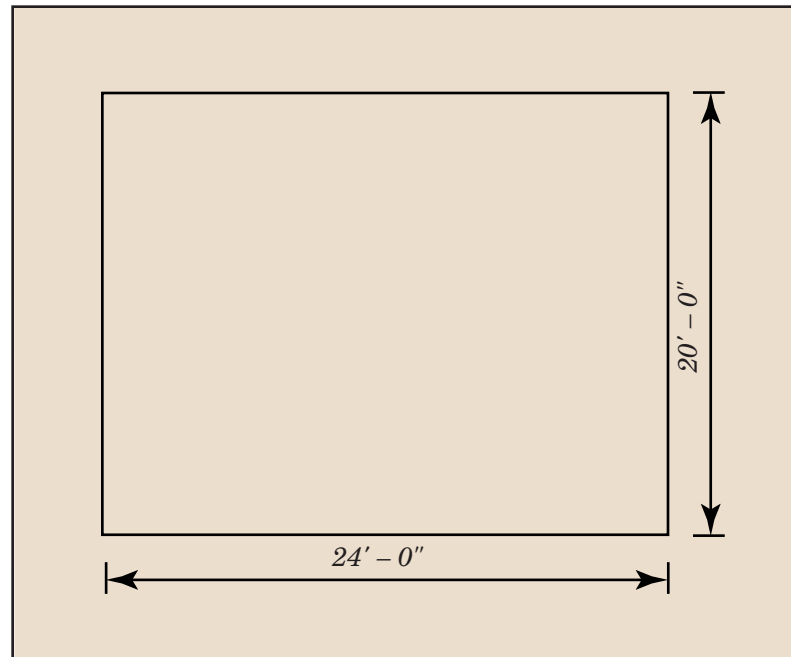

## OBJECTIVE 8

Optional Activities/  
Resources in Instructor's  
Guide

### Estimate number of form stakes needed for a job.

✓ **NOTE:** Some instructors estimate the number of stakes that will be needed to hold the ends of the boards where they meet along the form. If your instructor so requests, add this guideline to those given below. (Figure 4)

- Stakes are set approximately 3 feet apart. (Figure 4)
- Stakes are set at the end of each board at the form corners. (Figure 4)

**EXAMPLE:** Approximately 32 stakes will be needed for a form for a slab that will measure 24 feet long by 20 feet wide.

FIGURE 4

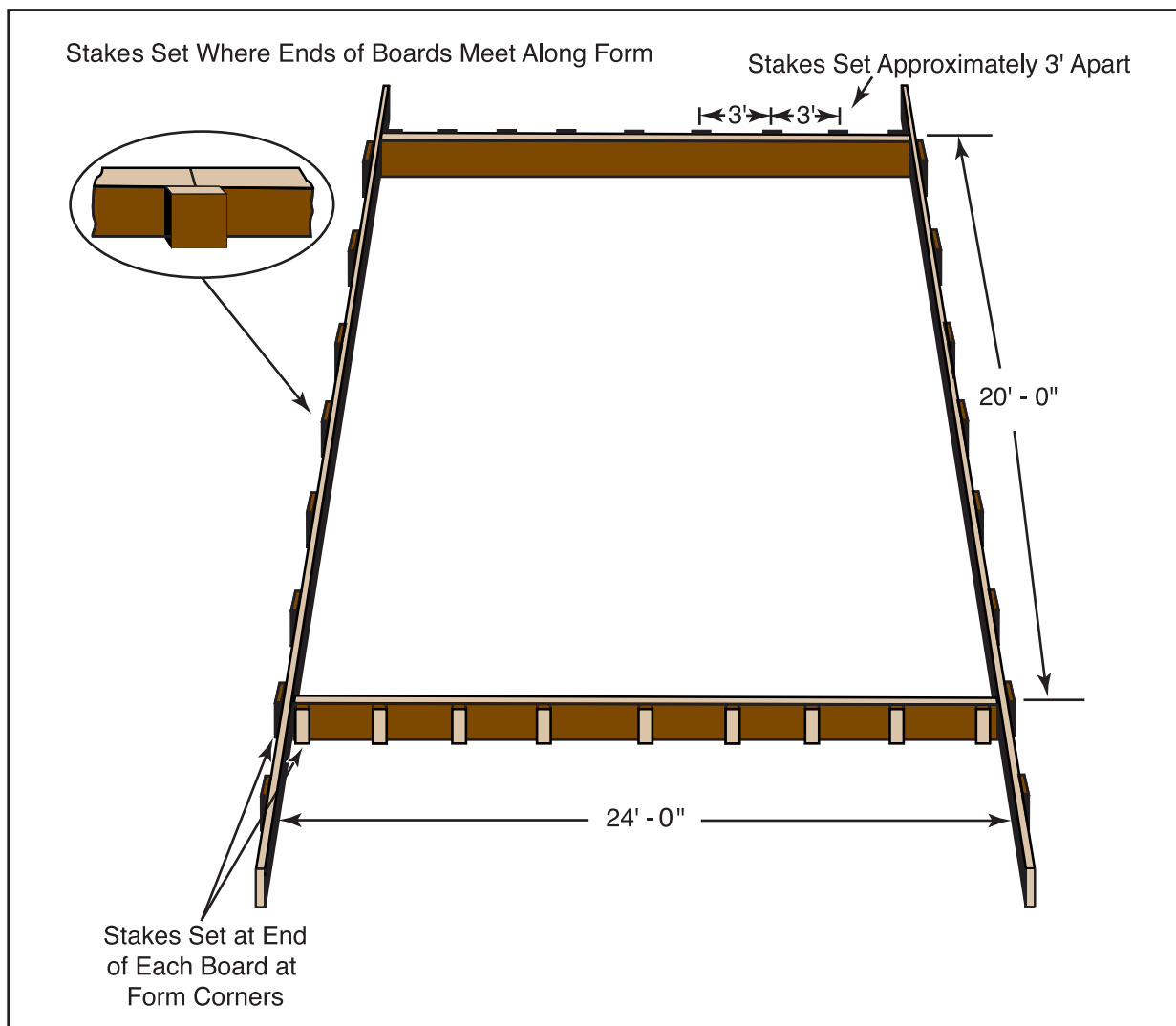

## OBJECTIVE 9

### Complete the Assignment Sheet.

STUDENT WORKBOOK - Concrete and Cement Masonry: Book One  
INFORMATION SHEET - CIMC - 7 - 9





Name \_\_\_\_\_ Score \_\_\_\_\_

OBJECTIVE 9

**Estimate the materials needed for a concrete job.**

BASIC SKILLS



Reading



Mathematics



Employability

INTRODUCTION

In order to write accurate orders for the concrete, welded wire fabric, form lumber, and form stakes needed for a job, a concrete mason must be skilled in using the methods of estimating. Practice using the various estimating materials by completing this assignment sheet.

EQUIPMENT AND SUPPLIES

- Pen or pencil

INSTRUCTIONS

**Part 1:** Estimating cubic yards of concrete with a concrete calculator

Using the concrete calculator your instructor will supply, estimate the cubic yards of concrete that will be needed for each of the jobs described. Write your answers on the blanks provided.

- A. How many cubic yards of concrete will be needed for the concrete floor in the drawing below?

Cubic yards of concrete = \_\_\_\_\_

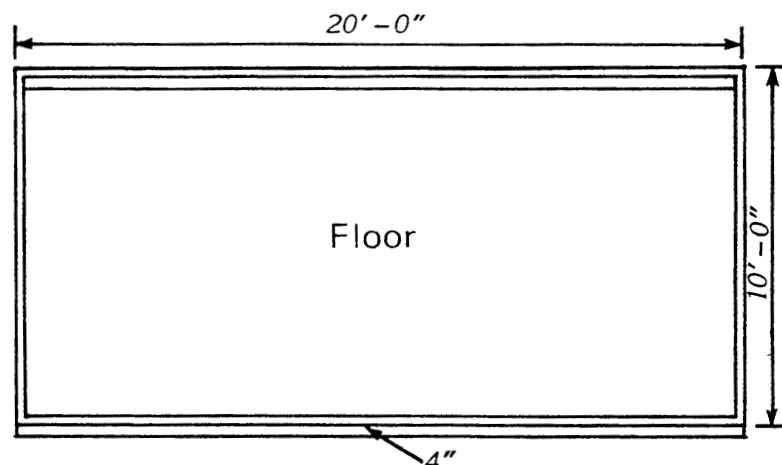

B. How many cubic yards of concrete will be needed for the concrete wall in the drawing below?

Cubic yards of concrete = \_\_\_\_\_

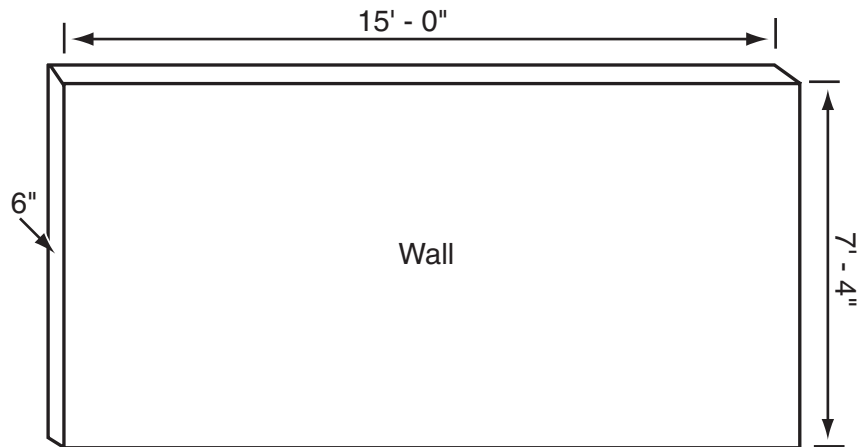

**Part 2:** Estimating cubic yards of concrete with an estimating table

Using the concrete estimating table below, estimate the cubic yards of concrete that will be needed for each of the jobs described on the following page. Show your work. Figure your answers to the nearest hundredth. Write your answers on the blanks provided.

One cubic yard of concrete will place					
Thickness	Sq ft	Thickness	Sq ft	Thickness	Sq ft
1" . . . . .	324	5" . . . . .	65	9" . . . . .	36
1 1/4" . . . . .	259	5 1/4" . . . . .	62	9 1/4" . . . . .	35
1 1/2" . . . . .	216	5 1/2" . . . . .	59	9 1/2" . . . . .	34
1 3/4" . . . . .	185	5 3/4" . . . . .	56	9 3/4" . . . . .	33
2" . . . . .	162	6" . . . . .	54	10" . . . . .	32.5
2 1/4" . . . . .	144	6 1/4" . . . . .	52	10 1/4" . . . . .	31.5
2 1/2" . . . . .	130	6 1/2" . . . . .	50	10 1/2" . . . . .	31
2 3/4" . . . . .	118	6 3/4" . . . . .	48	10 3/4" . . . . .	30
3" . . . . .	108	7" . . . . .	46	11" . . . . .	29.5
3 1/4" . . . . .	100	7 1/4" . . . . .	45	11 1/4" . . . . .	29
3 1/2" . . . . .	93	7 1/2" . . . . .	43	11 1/2" . . . . .	28
3 3/4" . . . . .	86	7 3/4" . . . . .	42	11 3/4" . . . . .	27.5
4" . . . . .	81	8" . . . . .	40	12" . . . . .	27
4 1/4" . . . . .	76	8 1/4" . . . . .	39	15" . . . . .	21.5
4 1/2" . . . . .	72	8 1/2" . . . . .	38	18" . . . . .	18
4 3/4" . . . . .	68	8 3/4" . . . . .	37	24" . . . . .	13.5



- A. How many cubic yards of concrete will be needed for the concrete slab in the drawing below?

Cubic yards of concrete = \_\_\_\_\_

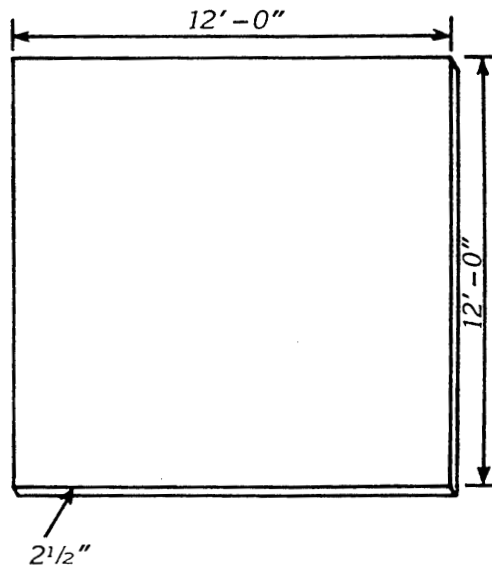

- B. How many cubic yards of concrete will be needed for the concrete slab in the drawing below?

Cubic yards of concrete = \_\_\_\_\_

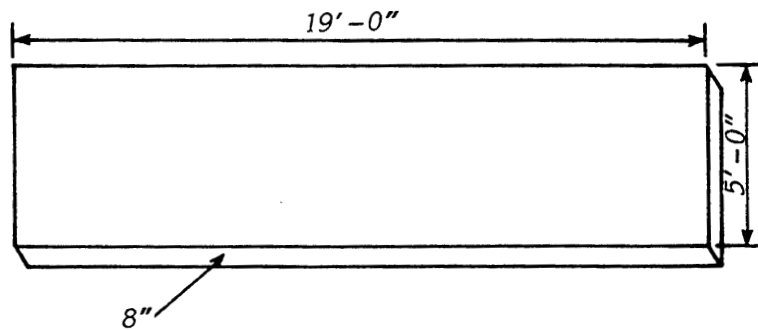

**Part 3:** Estimating cubic yards of concrete with the concrete estimating formula

Using the concrete estimating formula, estimate the cubic yards of concrete that will be needed for each of the jobs described. Show your work. Figure your answers to the nearest hundredth. Write your answers on the blanks provided.

- A. How many cubic yards of concrete will be needed for the concrete slab in the drawing below?

Cubic yards of concrete = \_\_\_\_\_

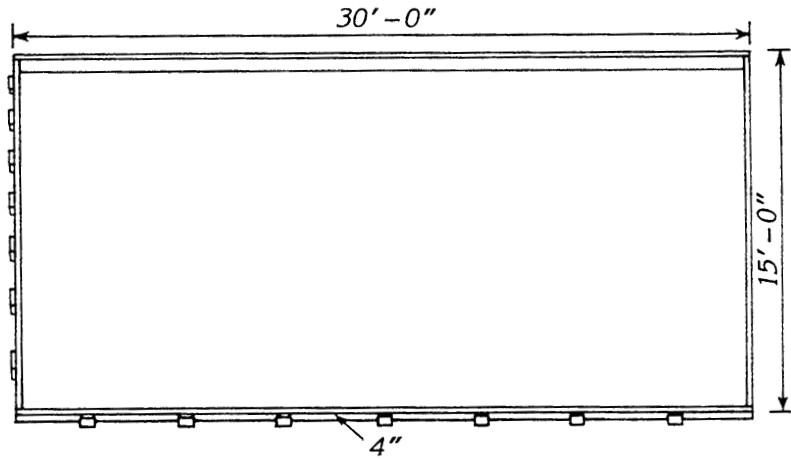

- B. How many cubic yards of concrete will be needed for the concrete slab in the drawing below?

Cubic yards of concrete = \_\_\_\_\_

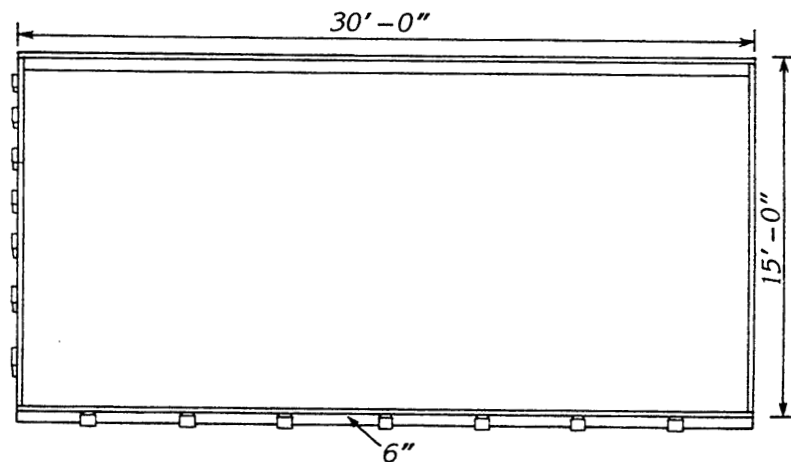

**Part 4:** Estimating rolls of welded wire fabric needed for a job

Using the steps you learned in the Information Sheet, estimate the number of rolls of welded wire fabric that will be needed for the job described below. Show your work. Figure your answer to the nearest hundredth. Write your answer on the blank provided.

Rolls of welded wire fabric = \_\_\_\_\_

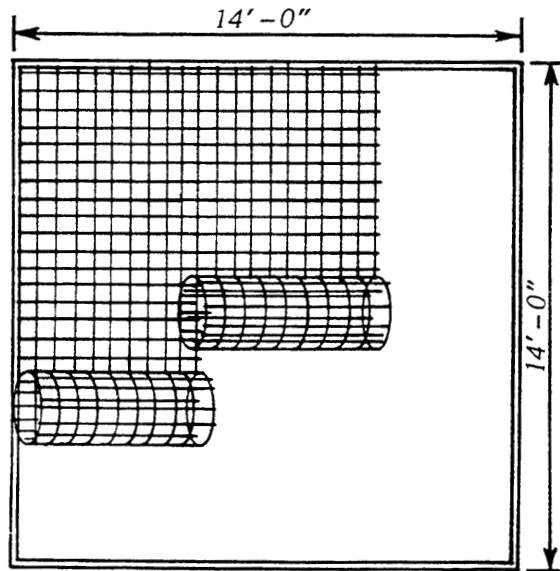

**Part 5:** Estimating the lineal feet of form lumber and the number of form stakes needed for a job

Using the guidelines you learned in the Information Sheet, estimate the lineal feet of form lumber and the number of form stakes that will be needed for the job described below. Show your work. Write your answer on the blank provided.

Lineal feet of form lumber = \_\_\_\_\_

Number of form stakes = \_\_\_\_\_

