



INTRODUCTION

Measuring is one of the first basic skills that a cement mason should master. Accurate measurements are very important. Cement masons should learn to use the correct tools and use them properly. When doing layout work there is no such thing as “good enough” or “close enough.” It should be accurate.

FOCUS ASSIGNMENTS

FOCUS ASSIGNMENTS	
1. Refer to the metric equivalency table in the Handout.	
2. Research the equivalents of the following:	
A. mile = _____ km	C. quart = _____ l
B. liter = _____ cu. in.	D. .39" = _____
 Reading	 Mathematics

UNIT OBJECTIVE

After completing this unit, you will show the following competencies by mastering the activities on the Assignment and Job Sheets and by scoring at least 85% on the Written Test.

SPECIFIC OBJECTIVES

1. Identify basic measuring tools used by cement masons.
2. List common errors that contribute to incorrect measurements.
3. Identify graduations on a folding rule.
4. Read a folding rule to the nearest fraction of an inch.
5. Convert fractional inches to hundredths of a foot.
6. Identify graduations on an engineer's rule.
7. Read an engineer's rule to the nearest hundredth of a foot.
8. Identify graduations on a tape.
9. Read a tape to the nearest fraction of an inch.



10. Discuss measuring methods used to square lines.
11. Read measurements on folding and engineer's rules. (Assignment Sheet 1)
12. Measure dimensions of objects. (Assignment Sheet 2)
13. Convert fractional inches to hundredths of a foot. (Assignment Sheet 3)
14. Read measurements on tapes. (Assignment Sheet 4)
15. Use basic measuring tools and the 3-4-5 method to lay out the perimeter of a building on a concrete slab. (Job Sheet)



OBJECTIVE 1

Optional Activities/
Resources in Instructor's
Guide

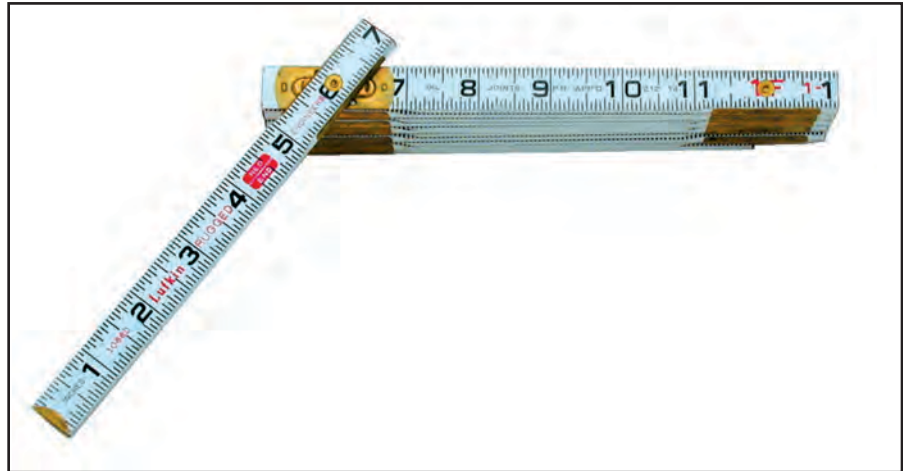
Identify basic measuring tools used by cement masons.

WORDS YOU SHOULD KNOW

foot unit of measure consisting of twelve equal parts called *inches*

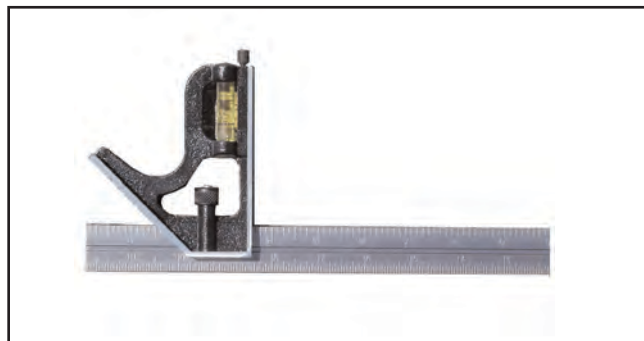
- Folding rule

FIGURE 1



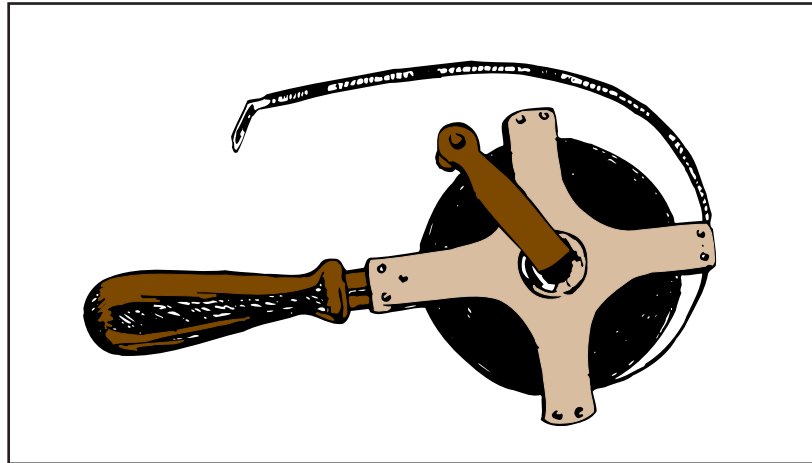
- Combination square

FIGURE 2



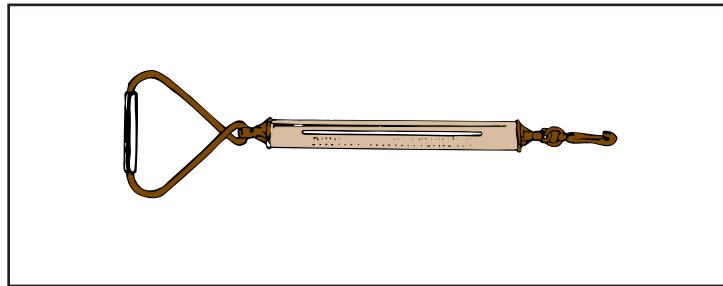
- Surveyor's steel tape (chain)

FIGURE 3



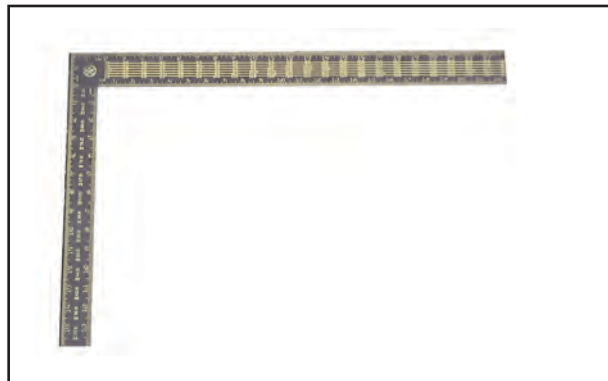
- Spring-balanced tape tension handle

FIGURE 4



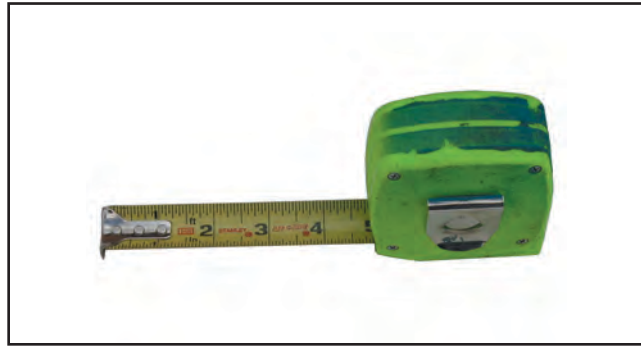
- Framing square

FIGURE 5



- Retractable steel tape

FIGURE 6



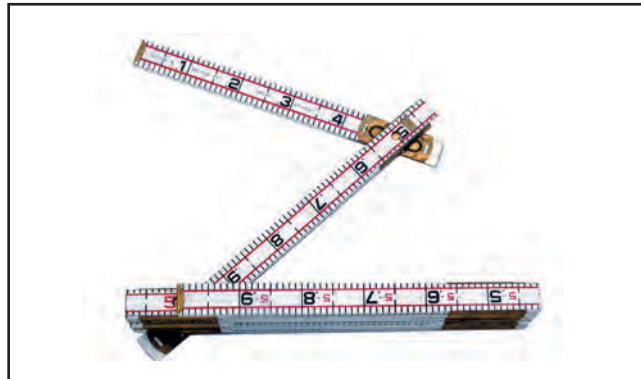
- One-hundred-foot steel tape

FIGURE 7



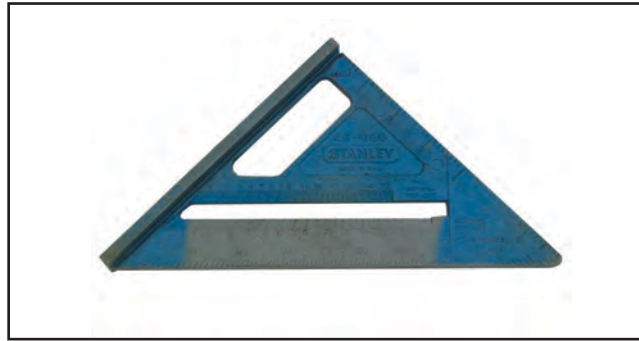
- Engineer's folding rule

FIGURE 8



- Speed square

FIGURE 9



OBJECTIVE 2

Optional Activities/
Resources in Instructor's
Guide

List common errors that contribute to incorrect measurements.

WORDS YOU SHOULD KNOW

measuring

setting of limits or bounds according to a predetermined standard

✓ **NOTE:** The standard used in measuring is called a unit of measurement or simply unit. Examples of units used to measure distance include inches, feet, meters, and miles.

- Leaving slack in tape
- Not laying tape flat (tape is twisted or kinked)
- Not aligning tape or rule properly
- Not placing end of tape or rule on reference point
- Reading incorrect number
- Recording incorrect number
- Using wrong reference point

EXAMPLE: When reading a diagonal measurement it is important to read the same side of the tape or rule for measurement.

- Making errors in mathematical computations

EXAMPLE: When converting from one unit of measurement to another

- Using incorrect measuring tool for job being performed



OBJECTIVE 3

Required Activities/
Resources
— Transparencies 1 and
2

Optional Activities/
Resources in Instructor's
Guide

Identify graduations on a folding rule.



Your instructor will show you transparencies which illustrate graduations on a folding rule.

WORDS YOU SHOULD KNOW

graduations

marks on a rule or tape indicating measurements

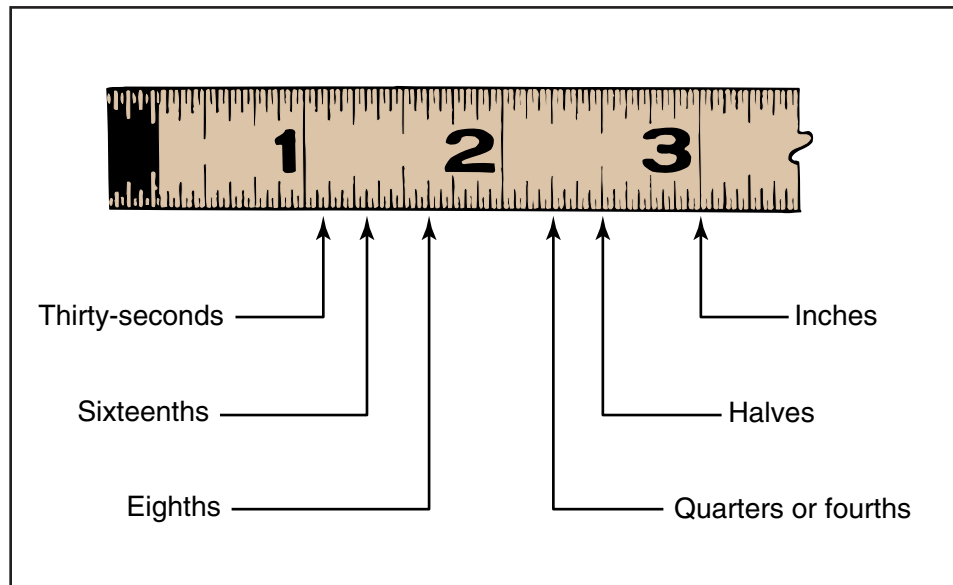
EXAMPLES: Sixteenths, quarters, halves, inches, and feet; hundredths, tenths, and feet

inch

smallest whole unit of lineal measure commonly used

✓ **NOTE:** Some rules will not have all of the graduations shown in Figure 10.

FIGURE 10



✓ **NOTE:** Sixteen 16ths equal 1 inch. Eight 8ths equal 1 inch. Four 4ths equal 1 inch. Two halves equal 1 inch. Twelve inches equal 1 foot.



OBJECTIVE 4

Required Activities/
Resources
— Transparencies 4-6

Optional Activities/
Resources in Instructor's
Guide

Read a rule to the nearest fraction of an inch.



Your instructor will show you transparencies which illustrate reading a rule to the nearest fractions.

WORDS YOU SHOULD KNOW

divisions	parts or sections on a rule that make up 1 inch
fraction	part of a whole; represents one or more equal parts of a unit EXAMPLES: $\frac{1}{2}$, $\frac{3}{8}$, $\frac{1}{4}$, $\frac{3}{16}$
layout	plan or design of the project to be constructed

✓ **NOTE:** All rules are read similarly. However, rules may have different graduations, and some rules may have special markings for specific purposes. Layout rules, for instance, are marked every 16 inches as an aid in determining stud locations on 16-inch centers.

1. Align the end of the rule with one reference point.
2. Determine the number of whole units between the end of the rule and the second reference point.

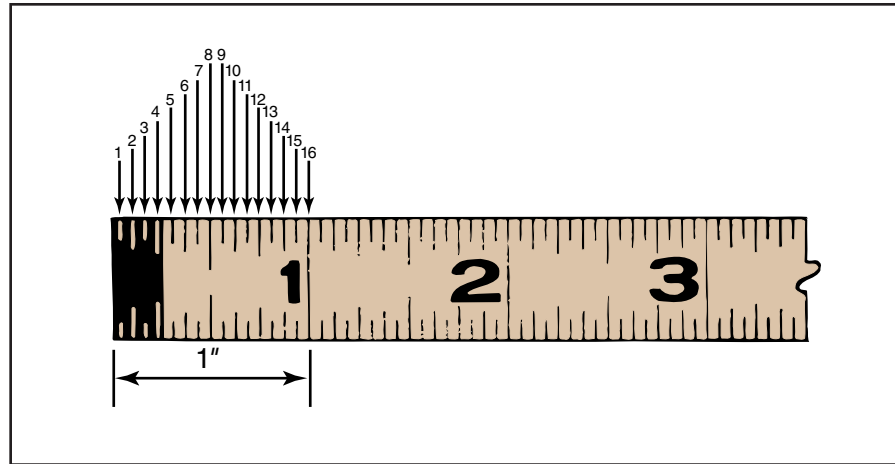
✓ **NOTE:** The unit of measurement will vary, depending on the distance being measured and the use being made of the measurement. Most short measurements are made in inches, even if they are more than 1 foot long. Skilled craftsmen are generally able to quickly convert measurements from feet to inches or vice versa for distances of 10 to 12 feet or more. Thus, a cement mason may speak of a ceiling as 4 by 8 feet or as 48 by 96 inches.

3. Determine the number of fractional units between the last whole unit and the second reference point.
 - a. Determine the number of graduations per inch (Figure 11).

✓ **NOTE:** At first you may have to count the number of divisions in an inch. However, with some practice, you will be able to recognize the divisions on sight and will eventually be able to determine fractional units just by looking at the rule.

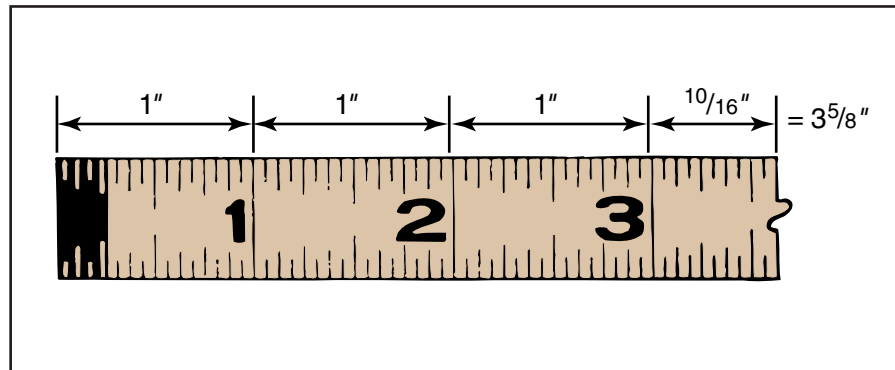


FIGURE 11



- b. Determine the fractional part of an inch by counting the number of divisions between the last inch and the second reference point.
- c. Reduce the fraction, if possible (Figure 12).

FIGURE 12



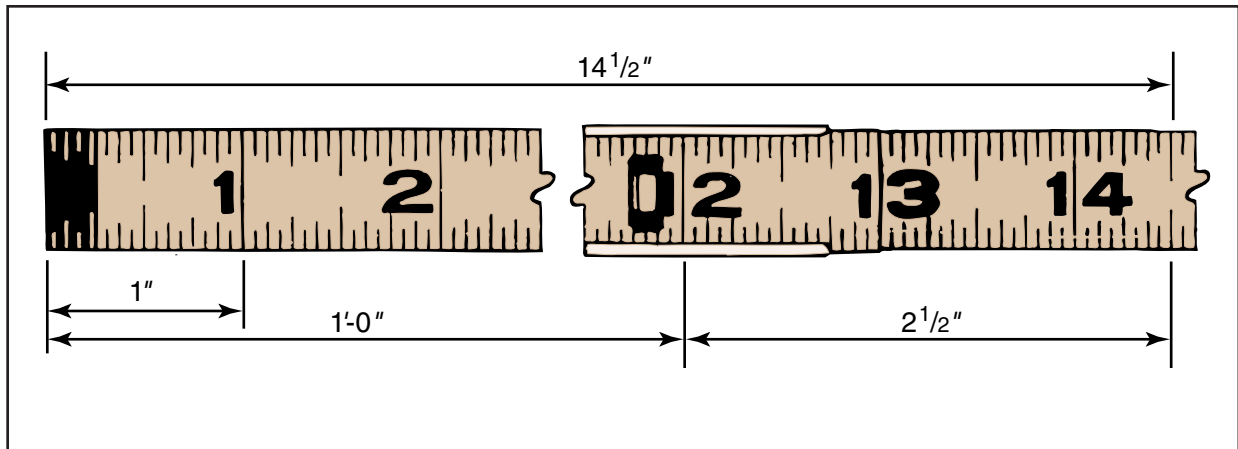
✓ **NOTE:** In the example above, the rule is divided into sixteenths. There are ten divisions between the last inch mark—3 inches—and the reference point. The $\frac{10}{16}$ can be reduced to $\frac{5}{8}$.

- 4. Determine the reading by adding fractional units to whole units and converting inches to feet or feet to inches if necessary (Figure 13).

EXAMPLE: The rule on the next page shows a measurement of 1'-2 $\frac{1}{2}$ " or 14 $\frac{1}{2}$ ".



FIGURE 13



OBJECTIVE 5

Optional Activities/
Resources in Instructor's
Guide

Convert fractional inches to hundredths of a foot.

✓ **NOTE:** There are two general methods used by the industry today for converting fractional inches to hundredths of a foot. One method is to apply the formula and rules described in this section. The formula is not exact, but it is generally accurate enough for the requirements of the trade and for use with the rules that a cement mason may have. The second method is to refer to a conversion table. See Table 1.

- Apply the following guidelines in the conversion process:
 1. Consider each 12 inches to be equal to 1.00 foot.
 2. Consider each $\frac{1}{8}$ inch to be equal to 0.01 foot.
 3. To allow for the difference between $\frac{1}{8}$ inch and 0.01 foot, add another 0.01 foot for 2 inches, 0.02 foot for 5 inches, 0.03 foot for 8 inches, and 0.04 foot for 11 inches.
- Use the following steps in the conversion process:
 1. Write the number of whole feet as a whole number to the left of the decimal point.
 2. Convert the remaining inches and fractional parts of inches to hundredths of a foot.
 - a. Change the inches and fractions to eighths, rounding sixteenths and thirty-seconds to the nearest eighths as necessary.
 - b. Multiply the numerator by 0.01.
 - c. Add the product of the two numbers to the whole-foot number.



3. Add the required number for quantities of 2 inches or more.

EXAMPLE 1: Convert $14'-5\frac{1}{4}"$ to hundredths of a foot.

- a. $14' = 14.00'$
b. $5\frac{1}{4}" = 2\frac{1}{4}" = \frac{42}{8}"$
c. $42 \times 0.01 = .42$
d. Add 0.02 for 5 inches

e.

$$\begin{array}{r} 14.00 \\ 0.42 \\ + 0.02 \\ \hline 14.44' \end{array}$$

EXAMPLE 2: Convert $5'-\frac{3}{16}"$ to hundredths of a foot.

- a. $5' = 5.00'$
b. $\frac{3}{16}" = 1\frac{5}{8}"$
c. $1\frac{5}{8}"$ rounds to $\frac{2}{8}"$
d. $2 \times 0.01 = .02$

e.

$$\begin{array}{r} 5.00 \\ + 0.02 \\ \hline 5.02' \end{array}$$



TABLE 1

Standard hundredths conversion

$\frac{1}{8}" = .01$	$\frac{3}{8}" = .26$	$6\frac{1}{8}" = .51$	$9\frac{1}{8}" = .76$
$\frac{1}{4}" = .02$	$\frac{3}{4}" = .27$	$6\frac{1}{4}" = .52$	$9\frac{1}{4}" = .77$
$\frac{3}{8}" = .03$	$\frac{3}{8}" = .28$	$6\frac{3}{8}" = .53$	$9\frac{3}{8}" = .78$
$\frac{1}{2}" = .04$	$\frac{3}{2}" = .29$	$6\frac{1}{2}" = .54$	$9\frac{1}{2}" = .79$
$\frac{5}{8}" = .05$	$\frac{5}{8}" = .30$	$6\frac{5}{8}" = .55$	$9\frac{5}{8}" = .80$
$\frac{3}{4}" = .06$	$\frac{3}{4}" = .31$	$6\frac{3}{4}" = .56$	$9\frac{3}{4}" = .81$
$\frac{7}{8}" = .07$	$\frac{7}{8}" = .32$	$6\frac{7}{8}" = .57$	$9\frac{7}{8}" = .82$
$1" = .08$	$4" = .33$	$7" = .58$	$10" = .83$
$1\frac{1}{8}" = .09$	$4\frac{1}{8}" = .34$	$7\frac{1}{8}" = .59$	$10\frac{1}{8}" = .84$
$1\frac{1}{4}" = .10$	$4\frac{1}{4}" = .35$	$7\frac{1}{4}" = .60$	$10\frac{1}{4}" = .85$
$1\frac{3}{8}" = .11$	$4\frac{3}{8}" = .36$	$7\frac{3}{8}" = .61$	$10\frac{3}{8}" = .86$
$1\frac{1}{2}" = .12$	$4\frac{1}{2}" = .37$	$7\frac{1}{2}" = .62$	$10\frac{1}{2}" = .87$
$1\frac{5}{8}" = .13$	$4\frac{5}{8}" = .38$	$7\frac{5}{8}" = .63$	$10\frac{5}{8}" = .88$
$1\frac{3}{4}" = .14$	$4\frac{3}{4}" = .39$	$7\frac{3}{4}" = .64$	$10\frac{3}{4}" = .89$
$1\frac{7}{8}" = .15$	$4\frac{7}{8}" = .40$	$7\frac{7}{8}" = .65$	$10\frac{7}{8}" = .90$
$2" = .16 + .01 = .17$	$5" = .41 + .01 = .42$	$8" = .66 + .01 = .67$	$11" = .91 + .01 = .92$
$2\frac{1}{8}" = .18$	$5\frac{1}{8}" = .43$	$8\frac{1}{8}" = .68$	$11\frac{1}{8}" = .93$
$2\frac{1}{4}" = .19$	$5\frac{1}{4}" = .44$	$8\frac{1}{4}" = .69$	$11\frac{1}{4}" = .94$
$2\frac{3}{8}" = .20$	$5\frac{3}{8}" = .45$	$8\frac{3}{8}" = .70$	$11\frac{3}{8}" = .95$
$2\frac{1}{2}" = .21$	$5\frac{1}{2}" = .46$	$8\frac{1}{2}" = .71$	$11\frac{1}{2}" = .96$
$2\frac{5}{8}" = .22$	$5\frac{5}{8}" = .47$	$8\frac{5}{8}" = .72$	$11\frac{5}{8}" = .97$
$2\frac{3}{4}" = .23$	$5\frac{3}{4}" = .48$	$8\frac{3}{4}" = .73$	$11\frac{3}{4}" = .98$
$2\frac{7}{8}" = .24$	$5\frac{7}{8}" = .49$	$8\frac{7}{8}" = .74$	$11\frac{7}{8}" = .99$
$3" = .25$	$6" = .50$	$9" = .75$	$12" = 1.00$



OBJECTIVE 6

Required Activities/
Resources
— Transparency 3

Optional Activities/
Resources in Instructor's
Guide

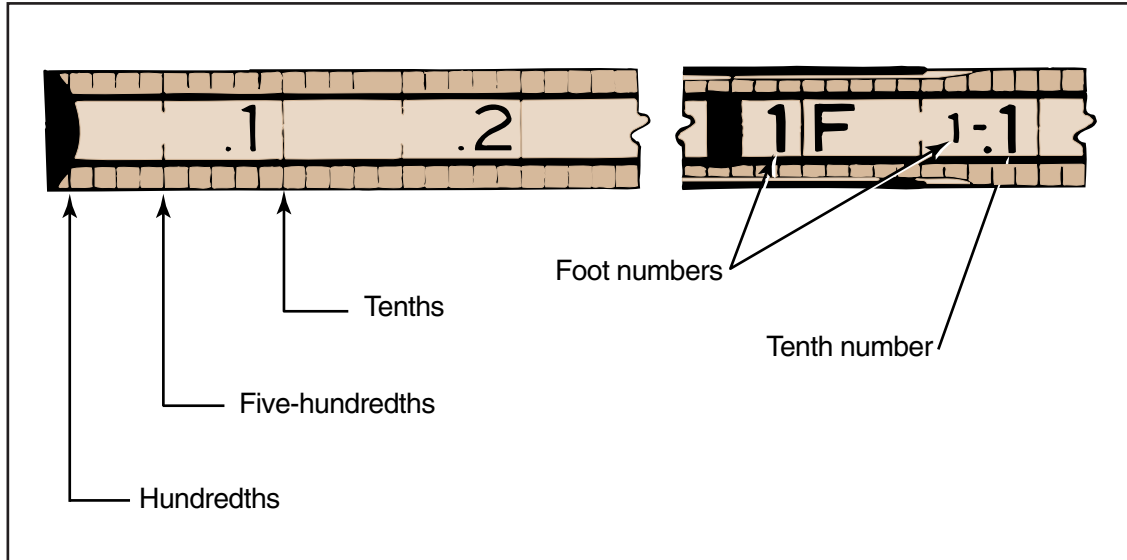
Identify graduations on an engineer's rule.



Your instructor will show you a transparency which illustrates graduations on an engineer's rule.

✓ **NOTE:** Many engineer's rules contain running foot indicators.

FIGURE 14



✓ **NOTE:** Ten 100ths equal $\frac{1}{10}$ of a foot. Two $\frac{5}{100}$ ths equal $\frac{1}{10}$ of a foot. Ten 10ths equal 1 foot. Notice that the other graduations on the engineer's rule are also commonly referred to. For example, twenty-five hundredths (0.25) is the same as $\frac{1}{4}$ foot or 3 inches, and fifty hundredths (0.050) is the same as $\frac{1}{2}$ foot or 6 inches.

OBJECTIVE 7

Required Activities/
Resources
— Transparency 3

Optional Activities/
Resources in Instructor's
Guide

Read an engineer's rule to the nearest hundredth of a foot.

1. Align the end of the rule with one reference point.
2. Determine the number of whole units between the end of the rule and the second reference point.

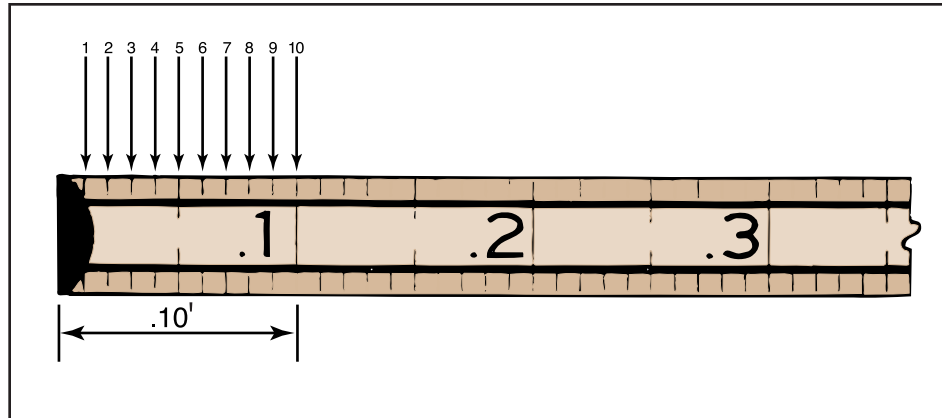
✓ **NOTE:** The units may be feet or tenths of a foot, depending on the distance measured and the use to be made of the measurement.



3. Determine the number of decimal units between the last whole unit and the second reference point.
 - a. Determine the number of graduations per unit (Figure 15).

EXAMPLE: A rule marked off in tenths of a foot may have graduations for each tenth of a tenth or each hundredth of a foot.

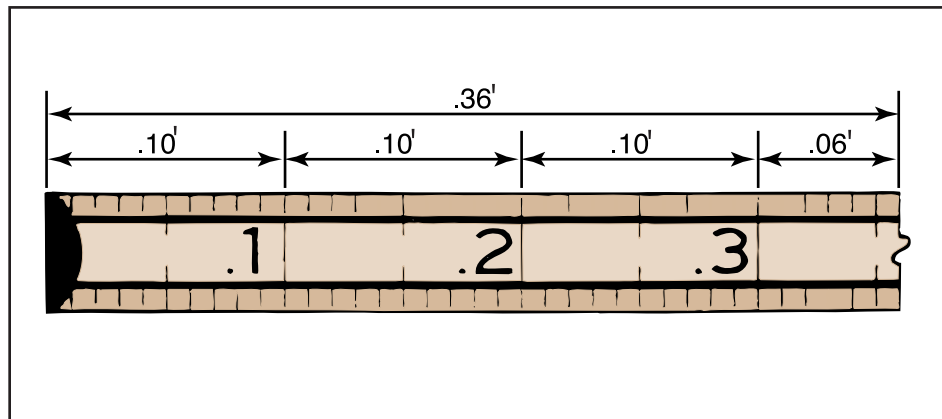
FIGURE 15



- b. Count the number of hundredths between the last full tenth and the second reference point (Figure 16).

EXAMPLE: The rule below shows a measurement of 36 hundredths of a foot, or 0.36'.

FIGURE 16

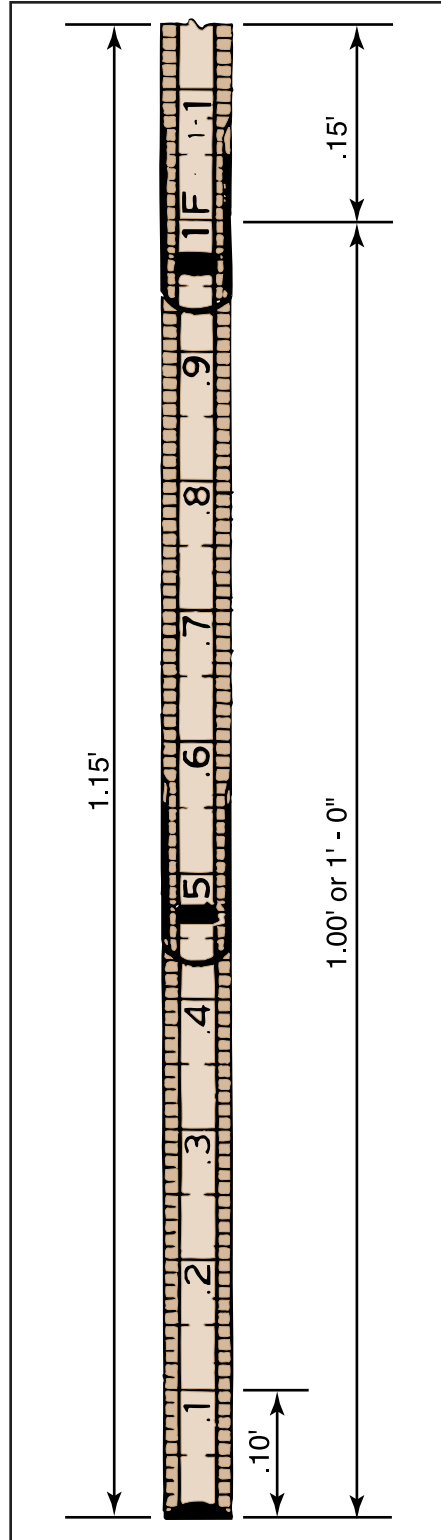


4. Determine the reading by adding decimal units to whole units and converting to feet and decimal parts of a foot, if desired (Figures 17 and 18).



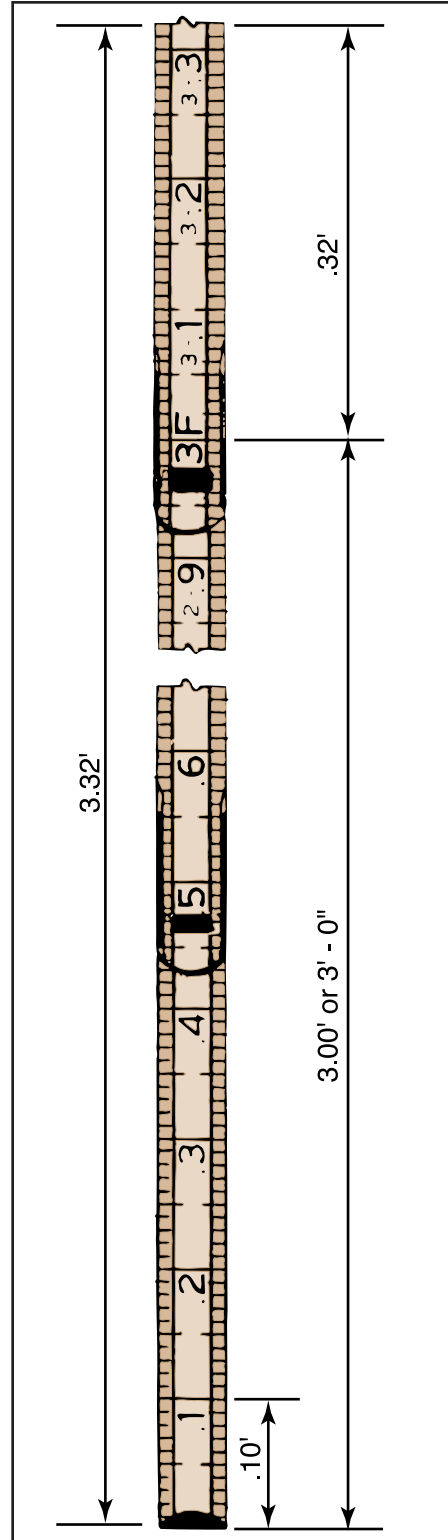
EXAMPLE 1: The rule below shows a measurement of 115 hundredths of a foot, or 1.15'.

FIGURE 17



EXAMPLE 2: The rule below shows a measurement of 332 hundredths of a foot, or 3.32'.

FIGURE 18



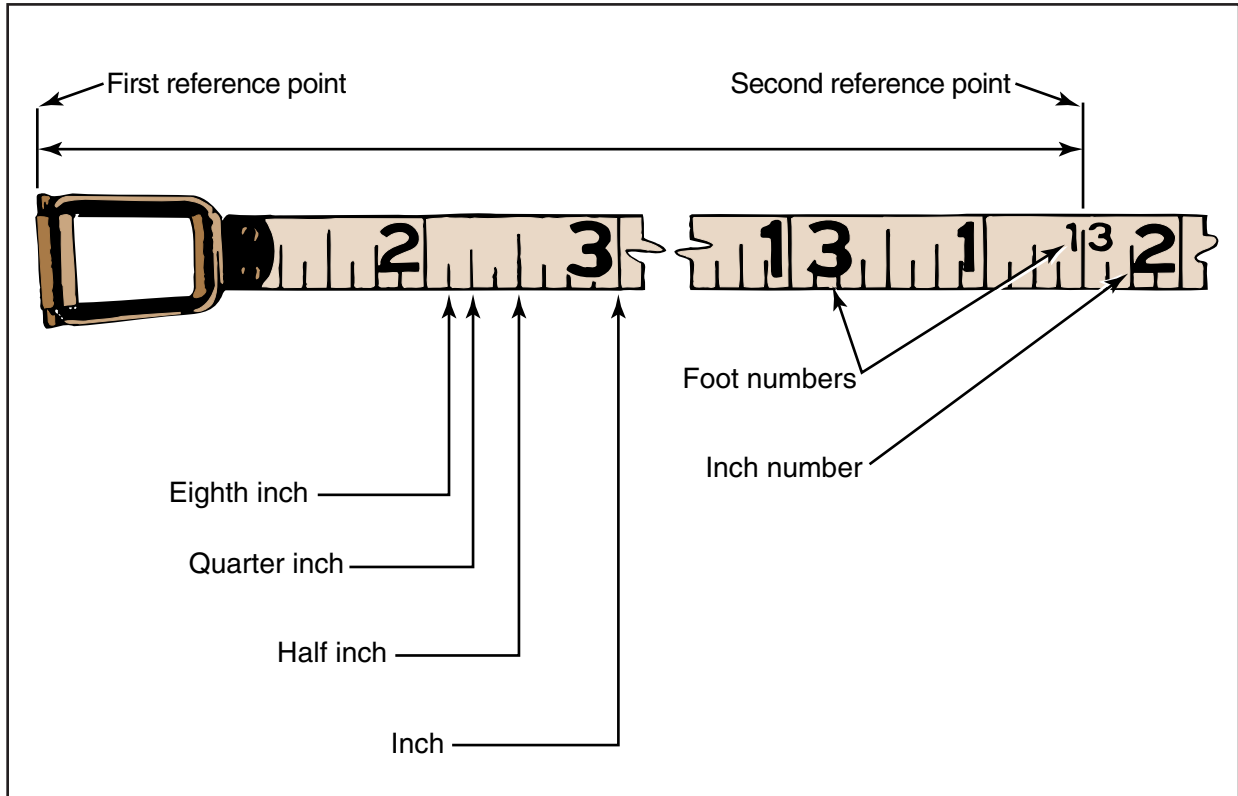
OBJECTIVE 8

Optional Activities/
Resources in Instructor's
Guide

Identify graduations on a tape.

✓ **NOTE:** The graduations on tapes are the same as the various graduations on rules, but because tapes are used to measure long distances, most tapes contain running foot indicators.

FIGURE 19



✓ **NOTE:** The tape in Figure 19 reads thirteen feet and one and one-half inches ($13' - 1\frac{1}{2}''$) at the second reference point.

OBJECTIVE 9

Optional Activities/
Resources in Instructor's
Guide

Read a tape to the nearest fraction of an inch.

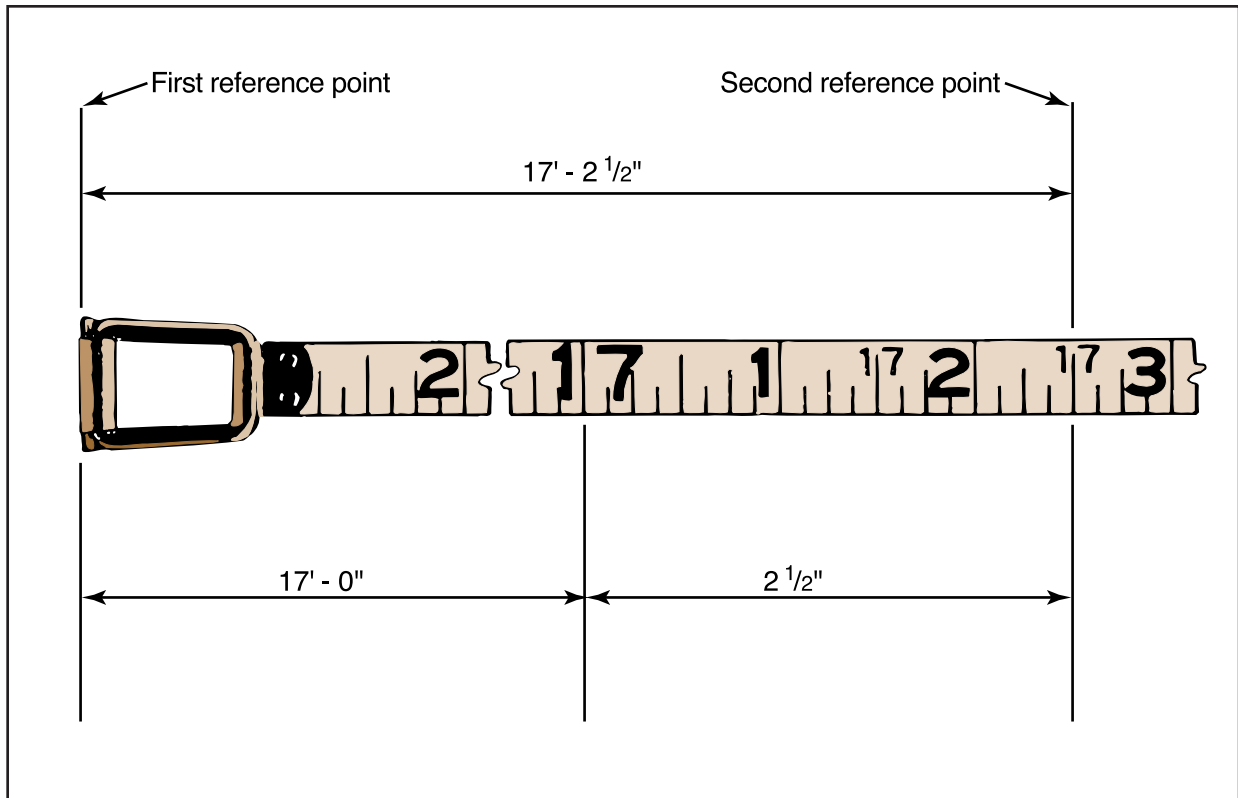
1. Place the end of the tape on one reference point.
2. Reading from the starting end of the tape, determine the number of feet to the second reference point.
3. Determine the number of inches between the last whole-foot mark and the second reference point.
4. Determine the fractional inches between the last whole-inch mark and the second reference point.



5. Add feet, inches, and fractions of an inch to obtain the correct measurement (Figure 20).

EXAMPLE: The tape below reads seventeen feet two and one-half inches ($17'-2\frac{1}{2}"$) at the second reference point.

FIGURE 20



OBJECTIVE 10

Optional Activities/
Resources in Instructor's
Guide

Discuss measuring methods used to square lines.

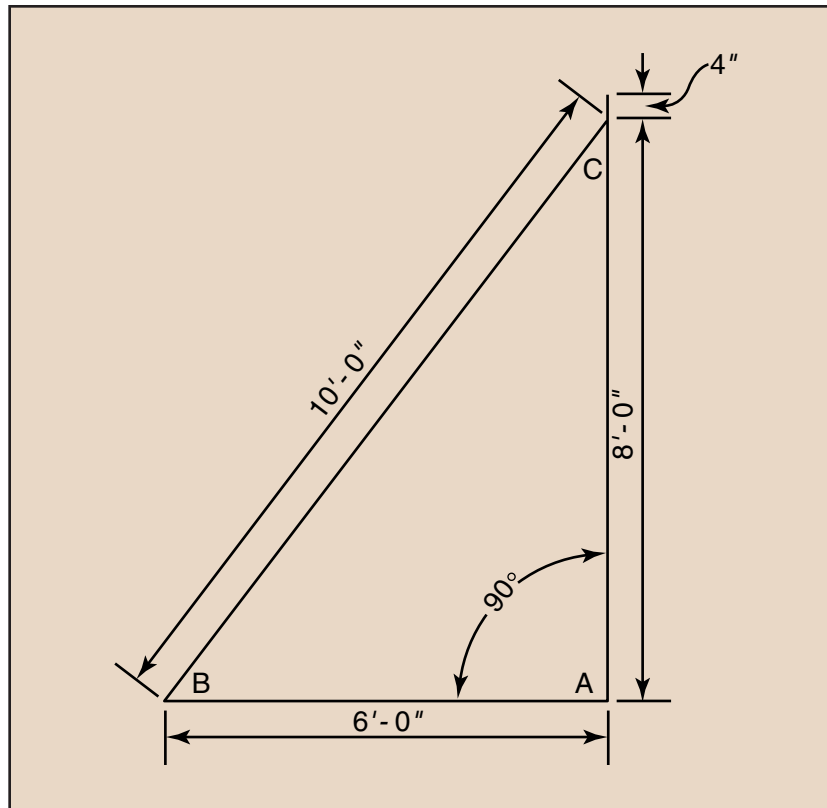
- **3-4-5 method** — Forming a right triangle using the largest multiple of 3-4-5 feet (6-8-10, 12-16-20, 24-32-40, etc.) possible for the length of lines being squared, and ensuring that the longest side of the triangle is the exact appropriate multiple of 5 (Figure 21).

EXAMPLE: Use the 3-4-5 method to square building lines 6'-0" and 8'-4".

- ✓ **NOTE:** The largest multiple that can be used is 6-8-10.



FIGURE 21

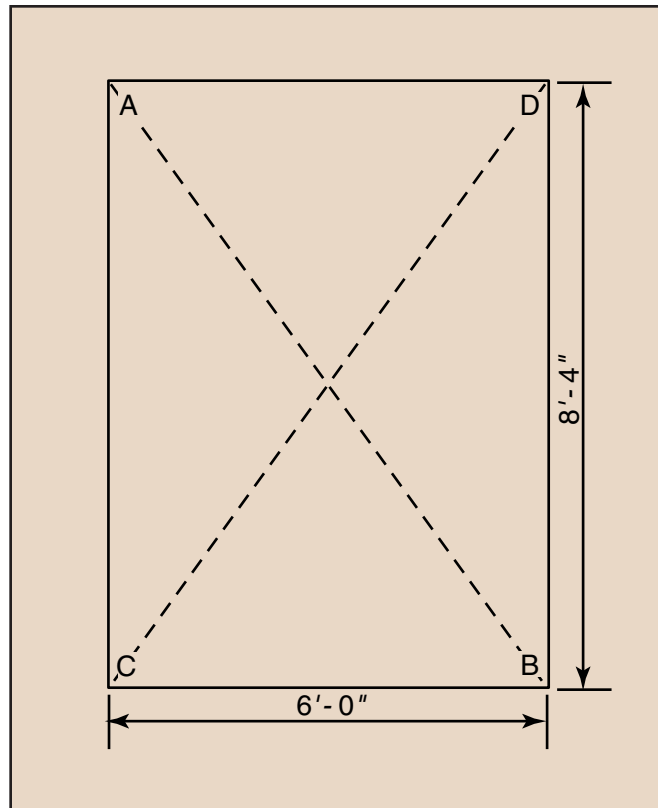


1. Measure 6 feet from point A to point B; mark.
 2. Measure 8 feet from point A to point C; mark.
 3. Measure from point B to point C.
 4. If the lines are square, the measurement from point B to point C will be exactly 10 feet; if the measurement is not exactly 10 feet, adjust one of the lines.
- **Diagonal method** — Measuring diagonally from the inside corners of the layout and ensuring the diagonal lines are equal in length (Figure 22).

EXAMPLE: Use the diagonal method to square building lines 6'-0" and 8'-4".



FIGURE 22



1. Measure diagonally from point A to point B.
2. Record this measurement.
3. Measure diagonally from point C to point D.
4. Record this measurement.
5. If the building lines are square, both diagonal measurements (AB and CD) will be exactly the same; if they are not exactly the same, adjust one or both of the lines.

OBJECTIVE 11 Complete Assignment Sheet 1.

OBJECTIVE 12 Complete Assignment Sheet 2.

OBJECTIVE 13 Complete Assignment Sheet 3.

OBJECTIVE 14 Complete Assignment Sheet 4.

OBJECTIVE 15 Complete the Job Sheet.





Name _____ Score _____

OBJECTIVE 11

Read measurements on folding and engineer's rules.

BASIC SKILLS



Reading



Mathematics



Employability

INTRODUCTION

The first step in being able to make accurate measurements is to become familiar with the graduations on rules and how to read them. This Assignment Sheet will allow you to practice reading measurements on rules.

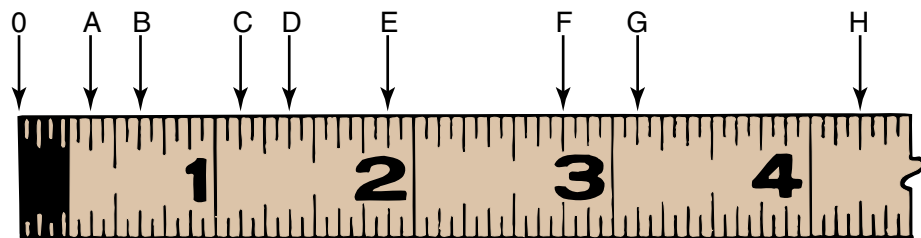
EQUIPMENT
AND SUPPLIES

- Pen or pencil

INSTRUCTIONS

Part 1: Read the rules illustrated below. Write your answers on the lines provided.

1.



A. = _____ E. = _____

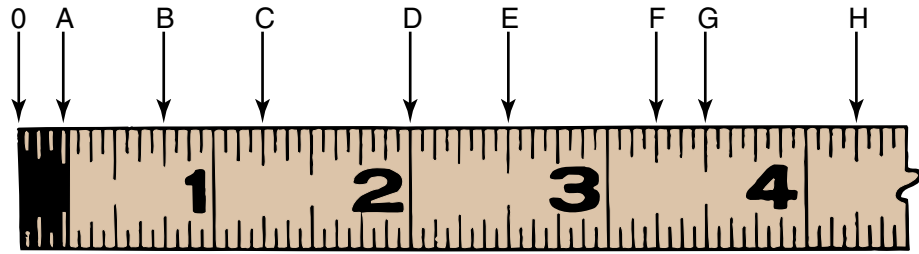
B. = _____ F. = _____

C. = _____ G. = _____

D. = _____ H. = _____



2.



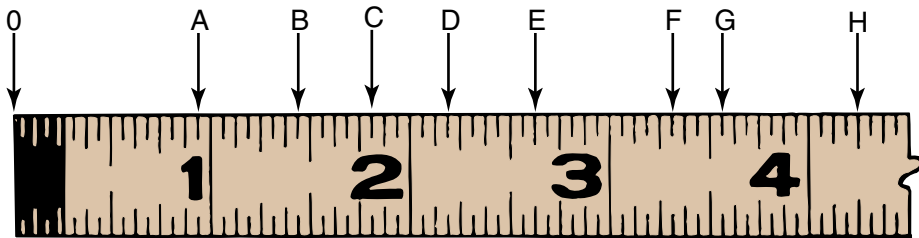
A. = _____ E. = _____

B. = _____ F. = _____

C. = _____ G. = _____

D. = _____ H. = _____

3.



A. = _____ E. = _____

B. = _____ F. = _____

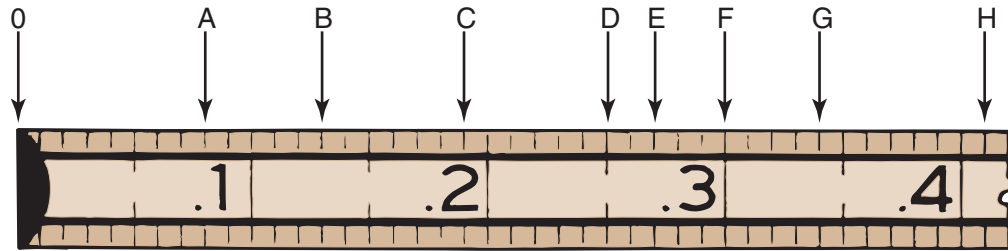
C. = _____ G. = _____

D. = _____ H. = _____



Part 2: Read the engineer's rules illustrated below. Write your answers on the lines provided.

1.



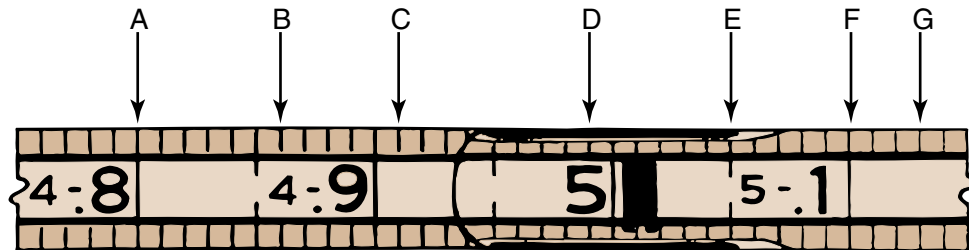
A. = _____ E. = _____

B. = _____ F. = _____

C. = _____ G. = _____

D. = _____ H. = _____

2.



A. = _____ E. = _____

B. = _____ F. = _____

C. = _____ G. = _____

D. = _____





Name _____ Score _____

OBJECTIVE 12

Measure dimensions of objects.

WORDS YOU SHOULD KNOW

dimensions arrangement of lines to indicate the actual size for constructing the object or structure represented

BASIC SKILLS



Reading



Mathematics



Employability

INTRODUCTION

A cement mason will use measuring skills in every phase of the job; thus, it is essential for the cement mason to master the ability to measure.

EQUIPMENT
AND SUPPLIES

- Ruler
- Pen or pencil

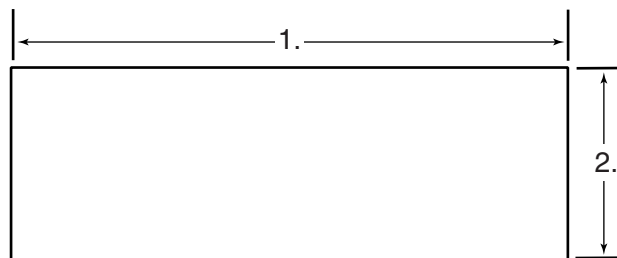
INSTRUCTIONS

Part 1

Measure the following objects, using a rule graduated in sixteenths of an inch.

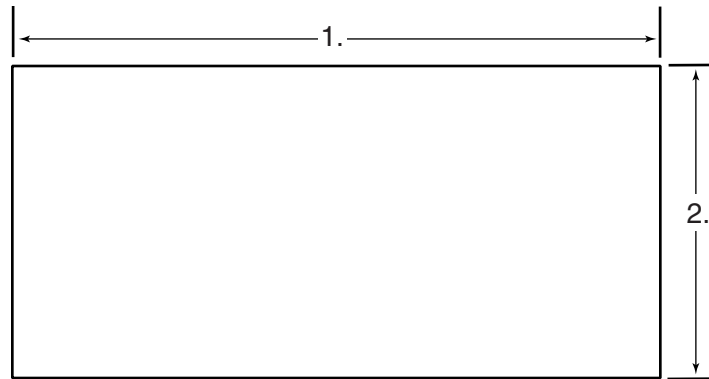
1. Length = _____

Height = _____



2. Length = _____

Height = _____

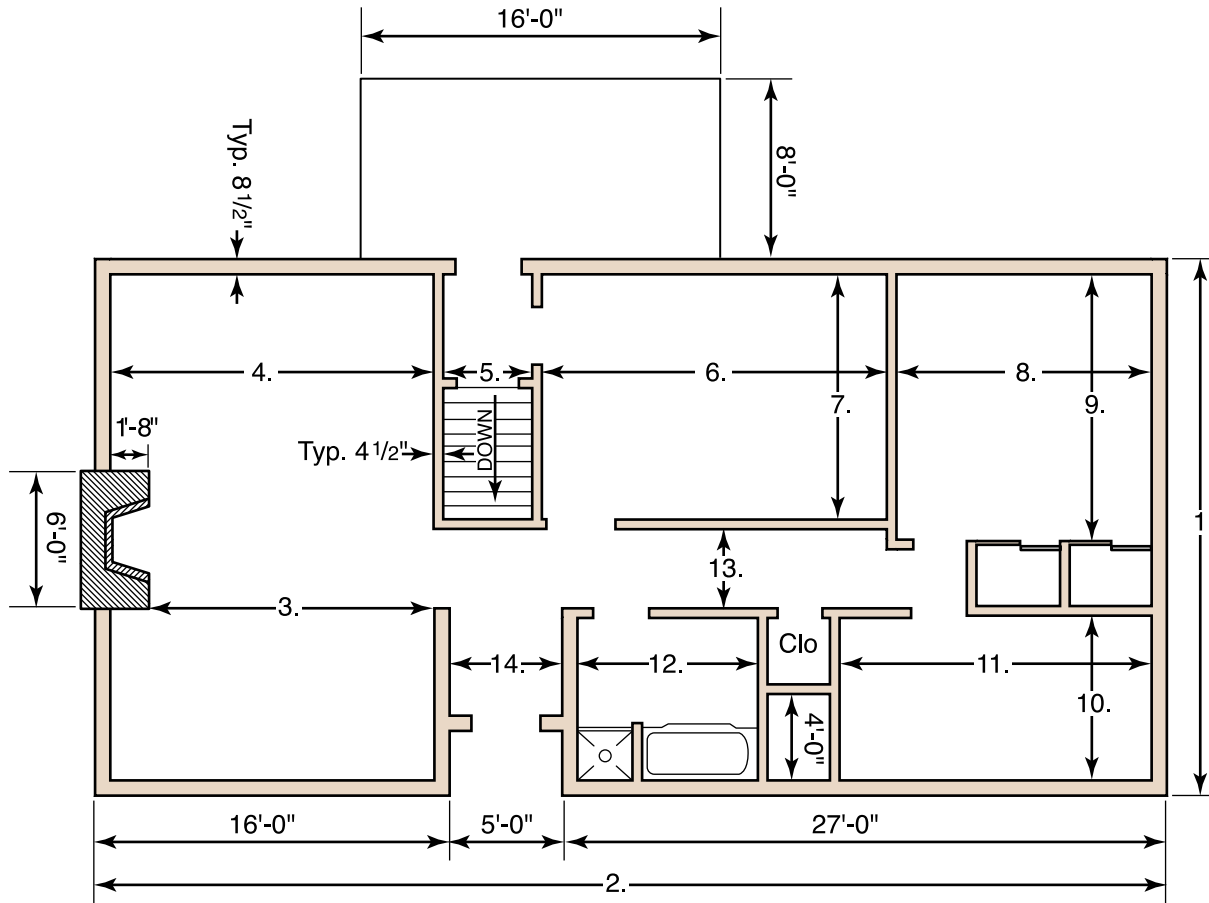


Part 2

Because of the size of projects, it is usually necessary to make scale drawings of houses, buildings, parking lots, site work, etc. A scale drawing uses one dimension to represent another, and all dimensions on the drawing are reduced in the same proportion. For example, using a scale in which 1 inch on the drawing is equal to 1 foot on the actual object 4 feet high and 5 feet long, the drawing would be 4 inches by 5 inches.

Using a scale of $\frac{1}{8}$ inch equals 1 foot, determine the dimensions represented on this plan. Write your answers in the blanks provided on the next page. Dimensions may be slightly distorted due to printing.





Scale: 1/8" = 1'-0"

- | | |
|------------|-------------|
| 1. = _____ | 8. = _____ |
| 2. = _____ | 9. = _____ |
| 3. = _____ | 10. = _____ |
| 4. = _____ | 11. = _____ |
| 5. = _____ | 12. = _____ |
| 6. = _____ | 13. = _____ |
| 7. = _____ | 14. = _____ |





Name _____ Score _____

OBJECTIVE 13

Convert fractional inches to hundredths of a foot.

BASIC SKILLS



Reading



Mathematics



Employability

INTRODUCTION

Many rules are marked in hundredths of a foot. Often the cement mason is required to convert inch dimensions to decimal fractions of a foot. This exercise will help you become more proficient at converting fractional inches to hundredths of a foot.

EQUIPMENT
AND SUPPLIES

- Pen or pencil

INSTRUCTIONS

Using the three guidelines below, convert the following inch dimensions to hundredths of a foot. Show your work.

- Consider each 12 inches to be equal to 1.00 foot
- Consider each $\frac{1}{8}$ inch to be equal to 0.01 foot
- Add 0.01 foot for 2 inches, 0.02 foot for 5 inches, 0.03 foot for 8 inches, and 0.04 foot for 11 inches

EXAMPLE: Convert $6'-4\frac{1}{8}"$ to hundredths of a foot.

- $6' = 6.00$
- $4\frac{1}{8}" = \frac{33}{8} = 0.33$
- Add 0.01
- $$\begin{array}{r} 6.00 \\ 0.33 \\ +0.01 \\ \hline 6.34' \end{array}$$



1. $\frac{1}{4}'' =$ _____ 2. $14'-5\frac{1}{2}'' =$ _____

3. $\frac{3}{4}'' =$ _____ 4. $6\frac{5}{8}'' =$ _____

5. $1\frac{3}{8}'' =$ _____ 6. $7'-7\frac{1}{8}'' =$ _____



Name _____ Score _____

OBJECTIVE 14

Read measurements on tapes.

BASIC SKILLS



Reading



Mathematics



Employability

INTRODUCTION

This exercise will help you to develop a better knowledge of reading a tape and will help you to read a tape quickly and efficiently.

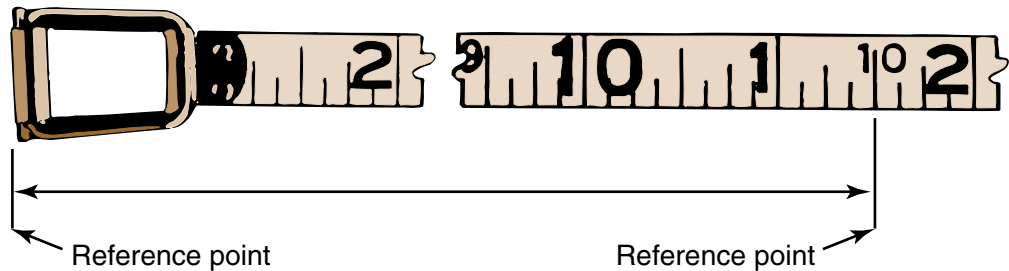
EQUIPMENT AND SUPPLIES

- Pen or pencil

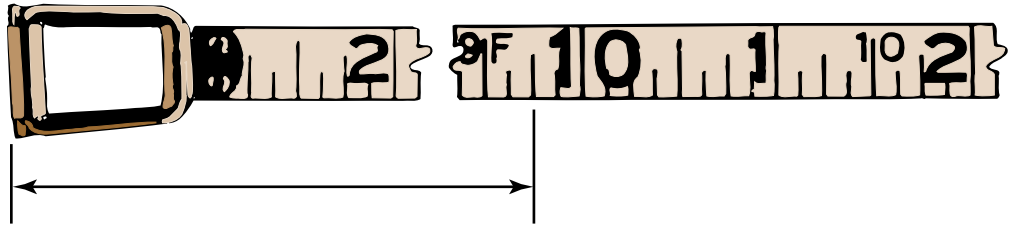
INSTRUCTIONS

Using the procedures outlined in Objective 10 of the Information Sheet, read the following tapes and write the correct dimensions on the lines.

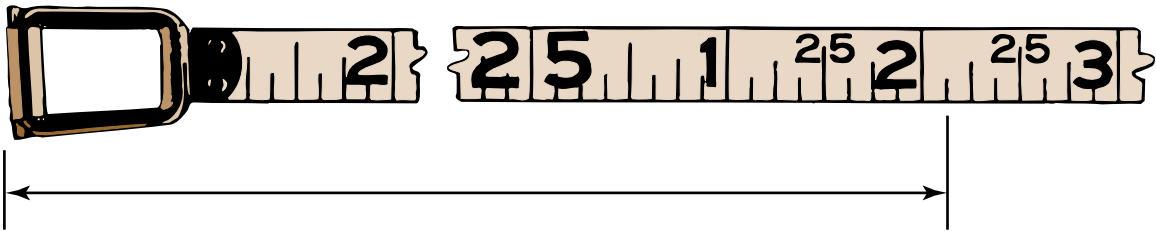
1. _____



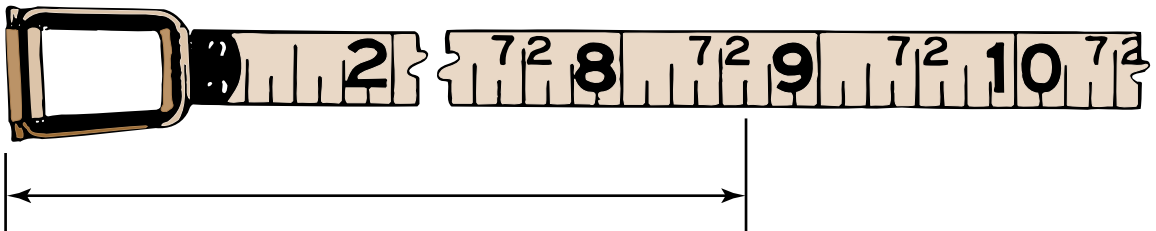
2. _____



3. _____



4. _____



Name _____ Score _____

OBJECTIVE 15

Use basic measuring tools and the 3-4-5 method to lay out the perimeter of a building on a concrete slab.

WORDS YOU SHOULD KNOW

keel	type of colored marking crayon used in construction
perimeter	outer limits or boundaries

BASIC SKILLS



INTRODUCTION

If a student plans to become a cement mason, it is important to learn how to lay out work. This Job Sheet will give you some practice and if the procedures are followed, you should be able to learn the steps necessary to complete the Job Sheet.

EQUIPMENT AND SUPPLIES

- Floor plan at end of Job Sheet (Figure 6)
- Two 50-foot or 100-foot tapes
- Chalk line
- Pen or pencil
- Keel
- Personal protective equipment

✓ **NOTE:** Refer to C.F.R. 1926.28 Sub Part C in regard to personal protective equipment.

PROCEDURE

✓ **NOTE:** Reference point A on the concrete slab will be designated by the instructor.

Yes No

1. Establish the point for the south wall (point B). (Figure 23)



Yes No

a. Have an assistant hold one end of a tape exactly on point A (southwest corner of the building).

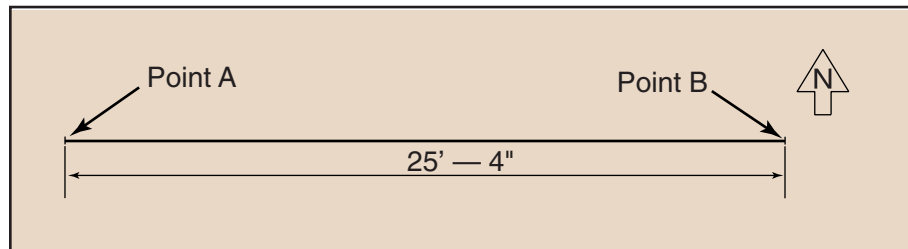
b. From point A, stretch the tape for the south wall to approximately 26 feet; mark on the concrete at exactly 25 feet 4 inches (point B).

✓ **NOTE:** Use keel to circle this and all marks so that they will be easy to identify.

c. Snap a line from point A to point B with a chalk line.

✓ **NOTE:** Be sure to keep the chalk line taut so that the line will be straight.

FIGURE 23



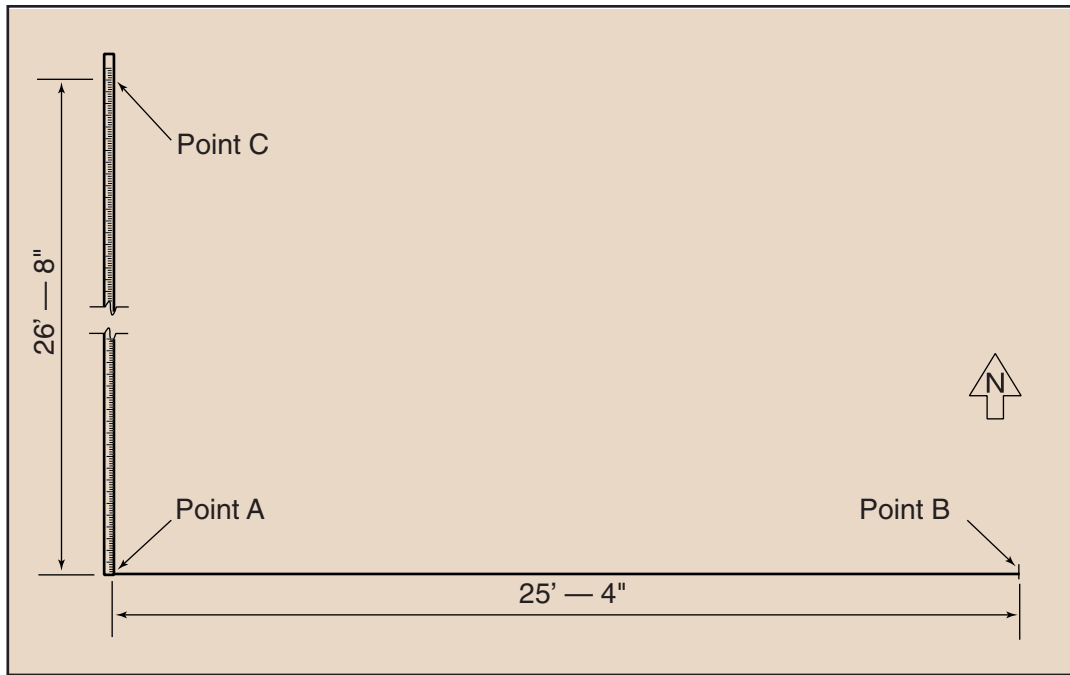
2. Establish the point for the west wall (point C). (Figure 24)

a. Have an assistant hold the end of the tape exactly on point A.

b. Stretch the tape for the west wall to approximately 27 feet; mark on the concrete at exactly 26 feet 8 inches (point C).



FIGURE 24



Yes No

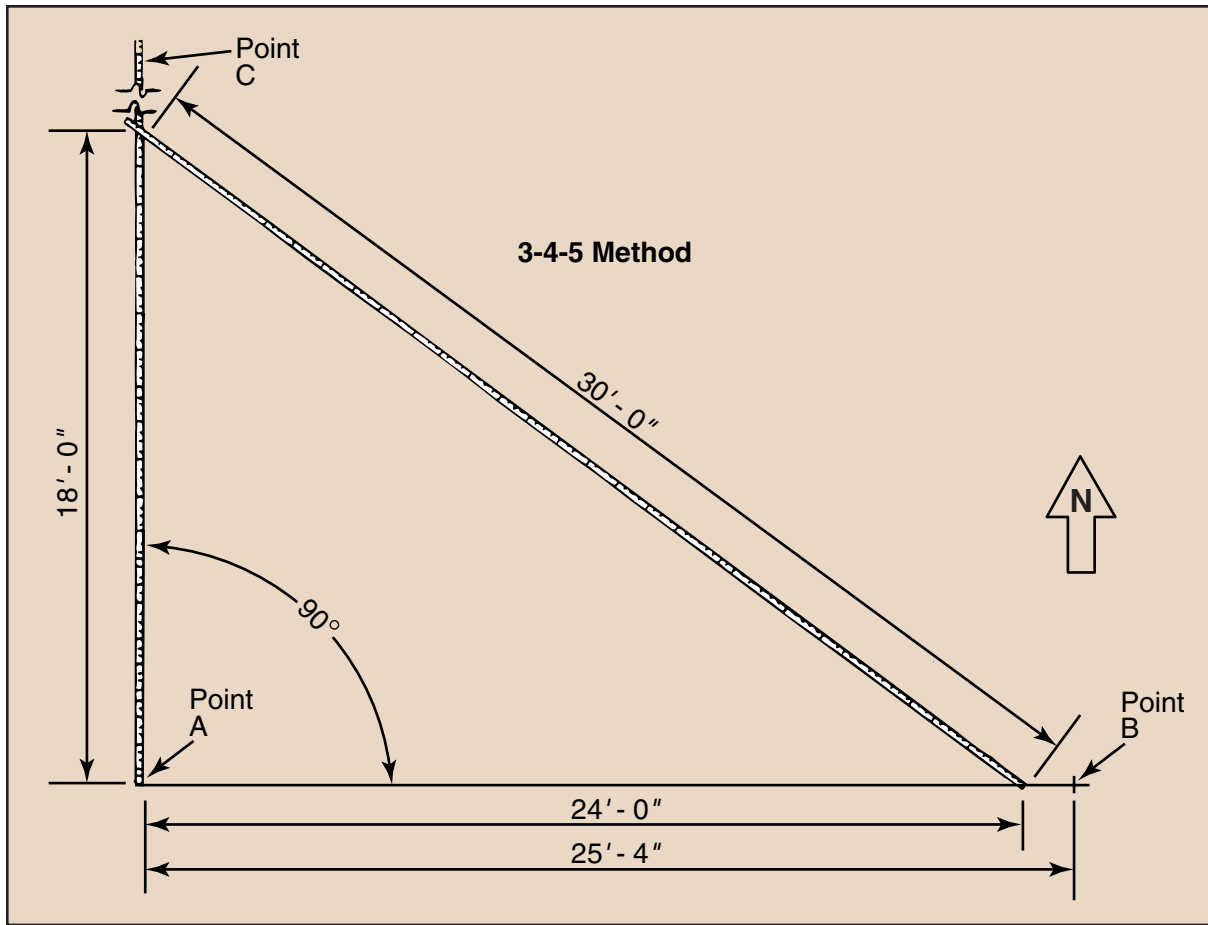
3. Before snapping the chalk line for the west wall (line A-C), use the 3-4-5 method to ensure that the line for this wall will be perpendicular to line A-B. (Figure 25)

✓ **NOTE:** In this particular project, the multiples of 18-24-30 are used.

- a. Starting at point A, measure to exactly 24 feet on line A-B; mark this point on the concrete.
- b. Have an assistant place the end of one tape exactly on point A; keeping the tape at a right angle to line AB, stretch the tape to 18 feet.
- c. Have another assistant place the end of a second tape exactly on the 24-foot mark on line AB; pull the second tape, at an angle, from the 24-foot mark on line AB to the 18-foot graduation on the first tape.
- d. Adjust the two tapes until the 30-foot graduation on the second tape crosses the 18-foot graduation on the first tape; mark this point on the concrete and remove both tapes.



FIGURE 25

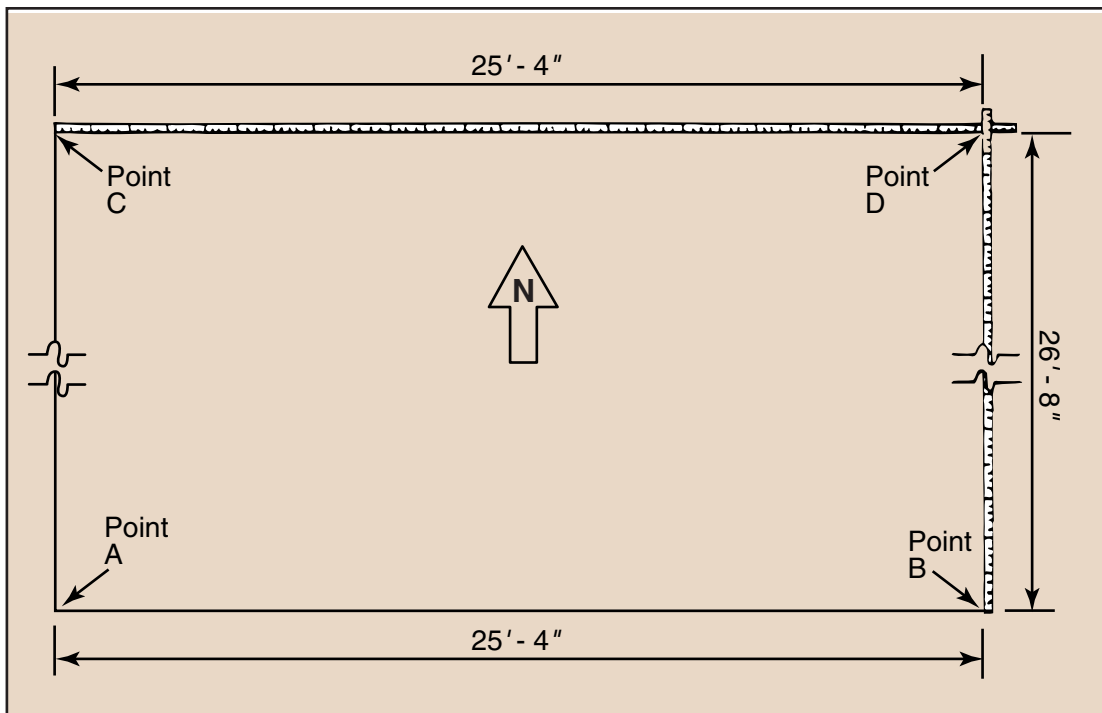


Yes No

- 4. Snap a line from point A to point C with a chalk line, making sure that the line passes directly through the point where 18-foot and 30-foot measurements crossed.
- 5. Establish the point for the east and north walls (point D). (Figure 26)
 - a. Have an assistant place the end of one tape exactly on point B; stretch the tape for the east wall to 26 feet 8 inches (point D).
 - b. Have another assistant place the end of a second tape exactly on point C; stretch the tape for the north wall to 25 feet 4 inches (point D).
 - c. Adjust the tapes until the 26-foot 8-inch graduation on the first tape crosses the 25-foot 4-inch graduation on the second tape; mark this point (point D) on the concrete and remove both tapes.



FIGURE 26

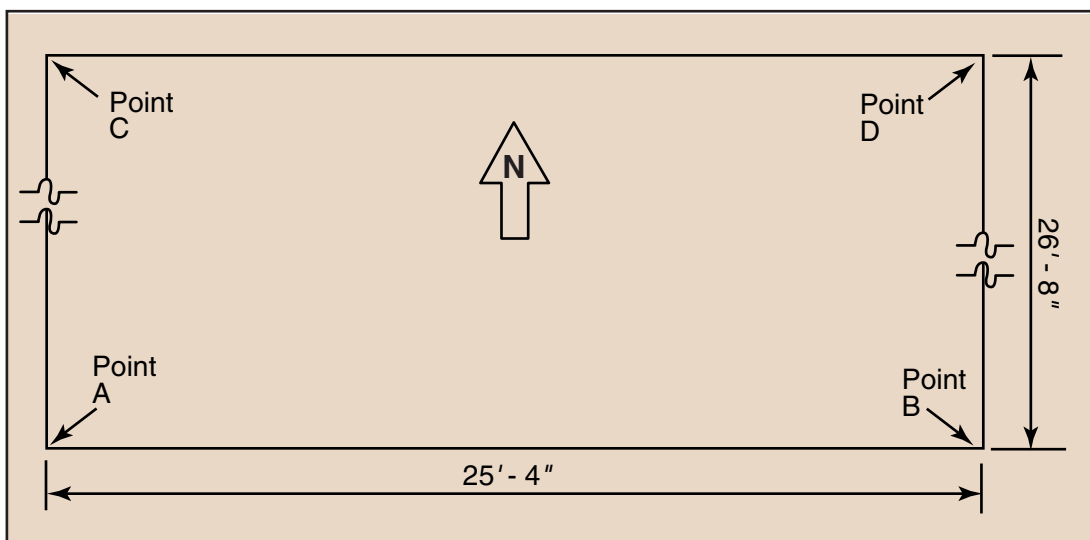


Yes No

6. Snap lines from points C to D and B to D with a chalk line.

✓ **NOTE:** You have now established the perimeter of the building. (Figure 27)

FIGURE 27

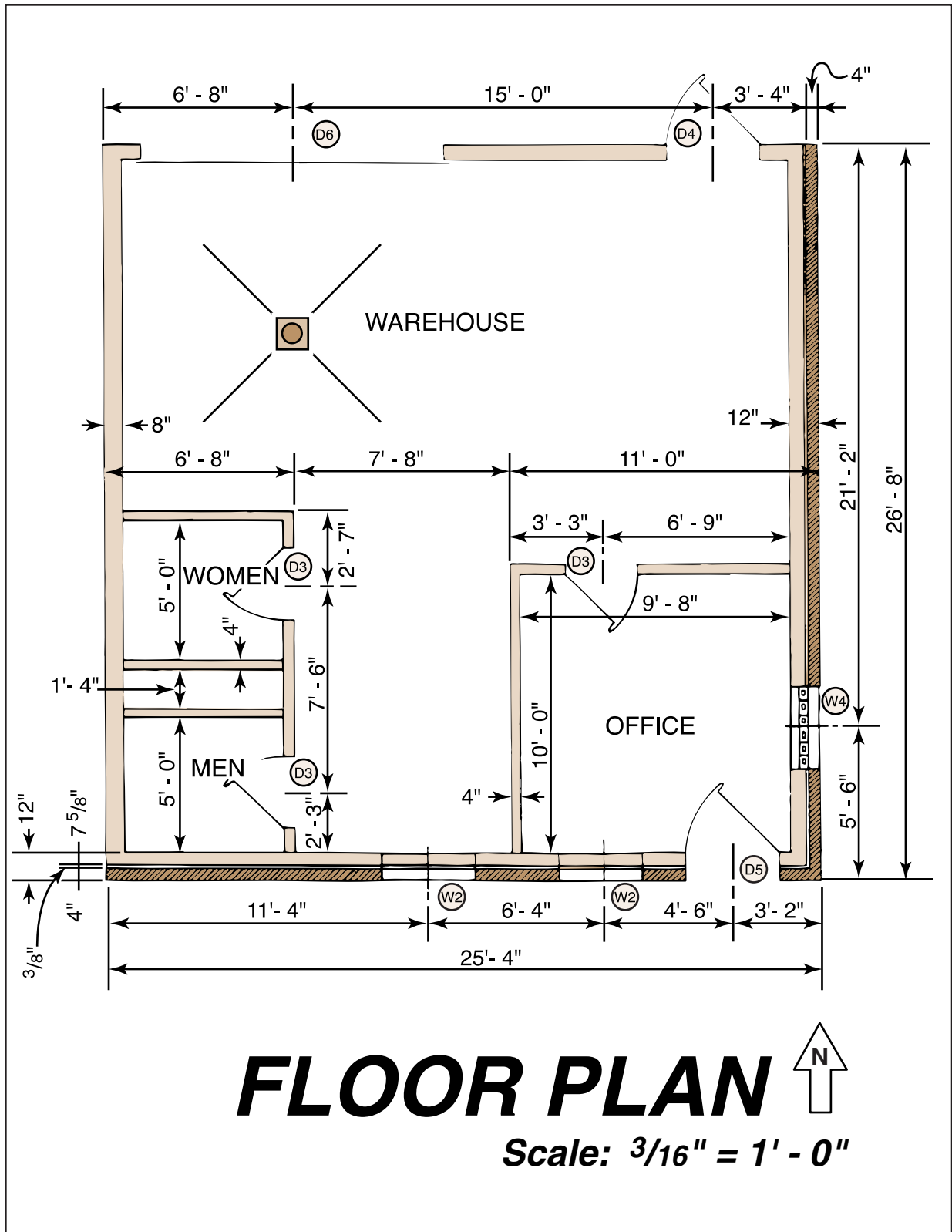


7. Clean up the work area and put away equipment and materials, or measure and lay out inside dimensions shown on the floor plan as directed by your instructor.





FIGURE 28



SKILL TEST RECORD

PRODUCT EVALUATION

Evaluator note: Rate the student on the following criteria by circling the appropriate numbers. Each criterion must receive a rating of “3” or higher to demonstrate student mastery. (See Key below.) A student who is unable to demonstrate mastery should review the material and submit another product for evaluation.

Criteria:

Accuracy of measurement	4	3	2	1
-------------------------	---	---	---	---

Readable chalk lines	4	3	2	1
----------------------	---	---	---	---

Accuracy of square	4	3	2	1
--------------------	---	---	---	---

AVERAGE RATING

Evaluator note: To obtain an average rating for the Profile of Training Mastery, total the points in Product Evaluation and divide by the total number of criteria. Circle the rating on the Key.

KEY

- 4 Skilled** — Can perform job with no additional training
- 3 Moderately Skilled** — Has performed job during training program; limited additional training may be required
- 2 Limited Skill** — Has performed job during training program; additional training is required to develop skill
- 1 Unskilled** — Is familiar with process, but is unable to perform job

EVALUATOR'S COMMENTS

