



INTRODUCTION

Placing concrete involves delivering the concrete from the supply and placing it at the established area inside the forms. Leveling involves leveling the concrete to a specific grade. Leveling may also be called *rodding, screeding and straight-edging, or dragging-off*.

FOCUS ASSIGNMENTS

FOCUS ASSIGNMENTS
<ol style="list-style-type: none">1. Watch a demonstration of concrete placing and leveling.2. What conclusions can you make? <div style="border: 1px solid black; height: 80px; margin: 10px 0;"></div> <div style="display: flex; justify-content: space-around; align-items: center;"><div style="text-align: center;"><p>Writing</p></div><div style="text-align: center;"><p>Critical Thinking</p></div></div>

UNIT OBJECTIVE

After completing this unit, you will show the following competencies by mastering the activities on the Assignment Sheet and by scoring at least 85% on the Written Test.

SPECIFIC OBJECTIVES

1. Compare placing and leveling.
2. Identify the starting point for placing concrete.
3. List items to inspect before placing concrete.
4. Distinguish among methods of leveling.
5. Identify starting points for placing concrete. (Assignment Sheet)





OBJECTIVE 1

Optional Activities/
Resources in Instructor's
Guide

Compare *placing* and *leveling*.

- **Placing** — Delivering concrete from the supply and placing it at the established area inside the forms
- **Leveling** — Leveling the concrete to a specific grade; also called *rodding*, *screeding* and *straight-edging*, or *dragging-off*

OBJECTIVE 2

Optional Activities/
Resources in Instructor's
Guide

Identify the starting point for placing concrete.

WORDS YOU SHOULD KNOW

cold joint	a joint that results when the first section hardens due to delay in placement, preventing a bond between the sections
-------------------	---

- Start placing concrete at the far point and work back toward the supply.
 - ✓ **NOTE:** The concrete supply could be at various locations on some jobs. You will need to carefully consider where to start placing the concrete.
- Work across the shortest distance, when possible, to help prevent cold joints. (Figure 1)
 - ✓ **NOTE:** Sometimes the longer distance is appropriate if it allows the finishers better accessibility to the starting point.

FIGURE 1

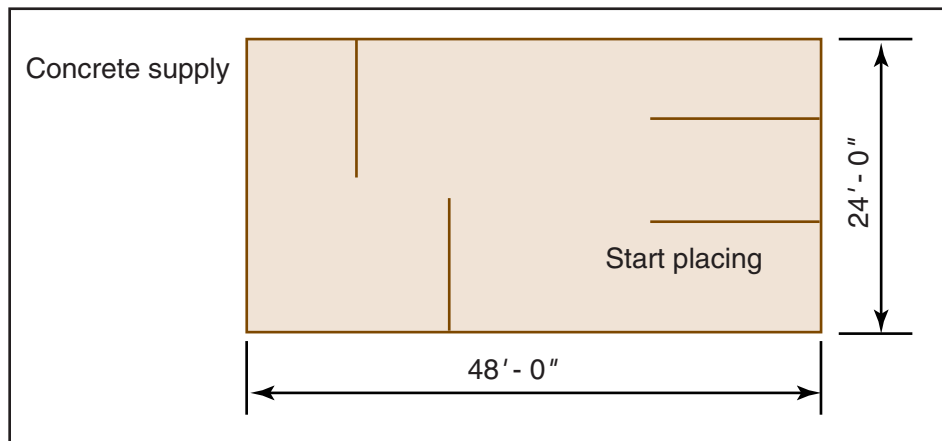

OBJECTIVE 3

Optional Activities/
Resources in Instructor's
Guide

List items to inspect before placing concrete.

WORDS YOU SHOULD KNOW

burning forms	when reinforcing steel is touching forms
subgrade	soil prepared and compacted to support a structure or a pavement system

Subgrade

- Subgrade firm and on grade
- Subgrade moist/wet down



NOTICE: Moist subgrade is important before placing concrete. It prevents absorption, prevents the concrete from setting early, and keeps the temperature of the concrete down. If the subgrade is dry and the temperature is hot, the subgrade will absorb the water from the concrete. This will cause the concrete to set too quickly and crack at the surface.

Forms

- Forms properly aligned and braced
- Forms on grade

Screeds

- Screeds set at proper location for efficient placing and finishing
- Screeds on grade

Equipment

- Finishing equipment available to the slab site
- Curing materials and equipment available to the slab site
- Barricade equipment available to the slab site
- Fire extinguishers within quick and easy access

Other

- Bulkheads properly set and on grade
- Reinforcing steel in place
- Reinforcing properly placed, not protruding or burning forms
- Drains properly set with floor for proper drainage (including holddown for tile)
- Expansion joint material in place and on grade
- Grades or forms set for any recesses in floor
- Cement mason informed of specified finish
- Cement mason informed of mix design



OBJECTIVE 4

Optional Activities/
Resources in Instructor's
Guide

Distinguish among methods of leveling.

WORDS YOU SHOULD KNOW

builder's level	an instrument consisting of a telescope, leveling bubble, fish eye, and tripod; used mainly for establishing elevations
line	string used as a guide in setting forms and grades
spirit level	tool used to determine the horizontal plane (level) by a bubble suspended in a vial of liquid

- **builder's level method** — Used for large jobs where other methods are not practical and where only a benchmark is given as grade (Figure 2)

FIGURE 2

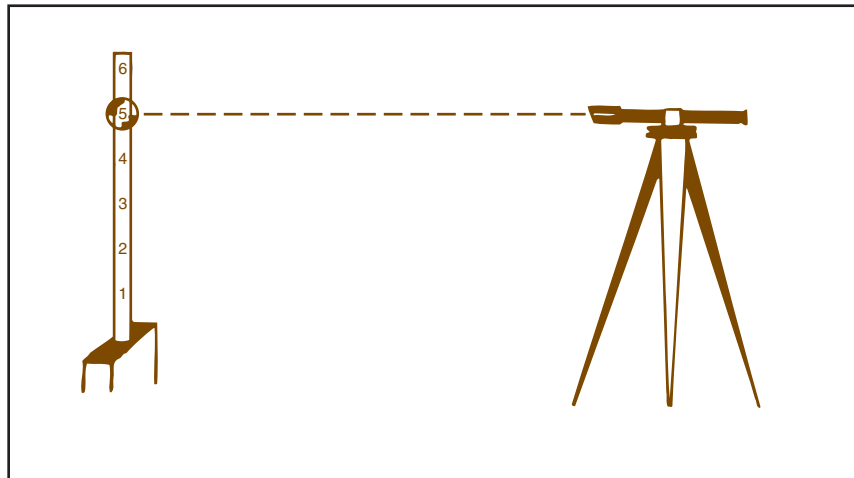

- **line method** — Used where the grade is given on two sides and where it is necessary to set the grade between the sides (Figure 3)

FIGURE 3

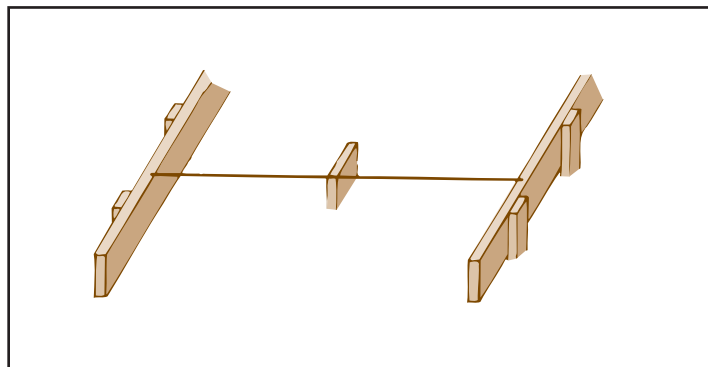

- **spirit level method** — Used wherever a level or straightedge will reach from the point of grade to the point where the grade is needed (Figure 4)

FIGURE 4

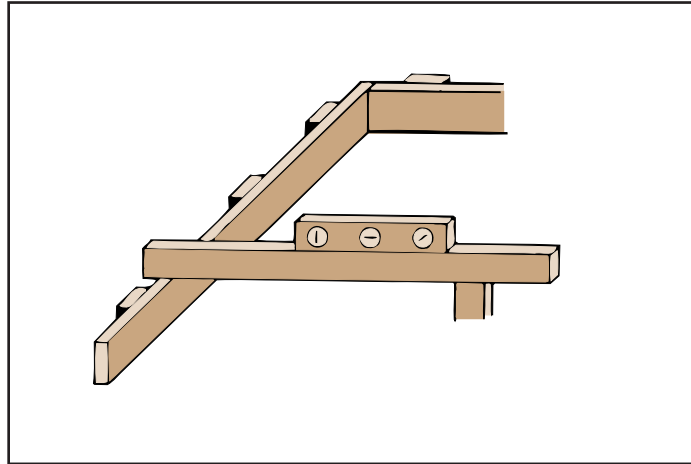

OBJECTIVE 5

Complete the Assignment Sheet.



Name _____ Score _____

OBJECTIVE 5

Identify starting points for placing concrete.

BASIC SKILLS



Mathematics



Science



Critical Thinking

INTRODUCTION

It is important to know where to start placing concrete for a slab, and where to position the concrete truck or pump. The quickest and most efficient delivery must be considered to avoid cold joints. The shortest runs for rodding also need to be considered, to keep from having cold joints. The most convenient method of working and finishing the concrete should be considered. If all of these items are not taken into consideration, the results could cause you to be unable to use some tools, such as bull floats, efficiently and you may not be able to get other equipment, such as power floats and trowels, where and when they are needed. You could end up with cold joints, a poor finish, and a costly slab. Identifying the location to start placing concrete in the following illustrations will give you some practice and may help you in the future.

EQUIPMENT AND SUPPLIES

- Pen or pencil

INSTRUCTIONS

- Identify where to start placing concrete by circling the correct letter on the following illustrations and be prepared to give the reasons for your choices.

You may also use the drop-downs below to select your answer choice.



1.

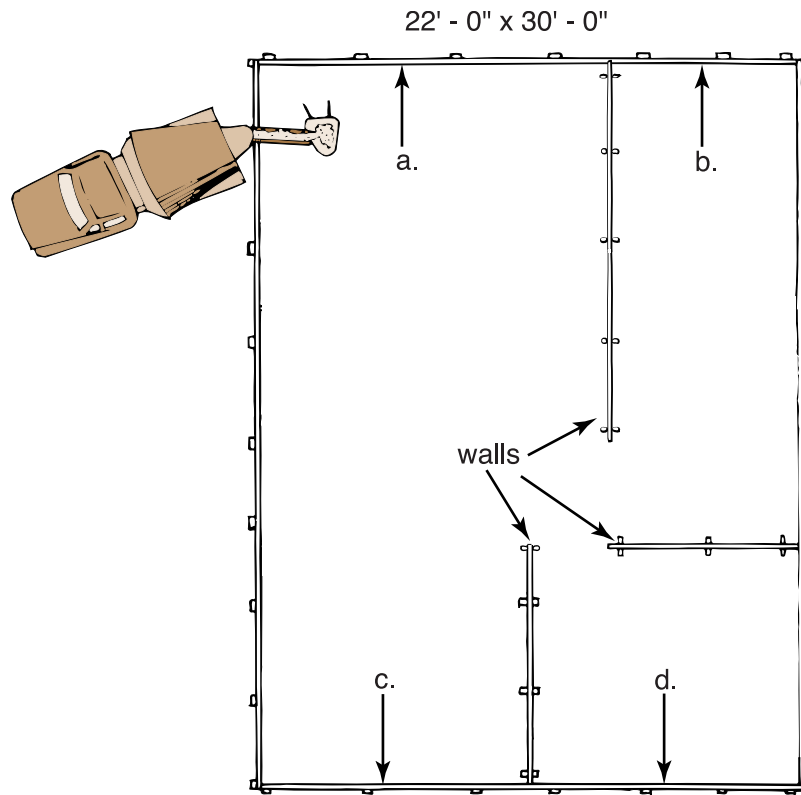

2.

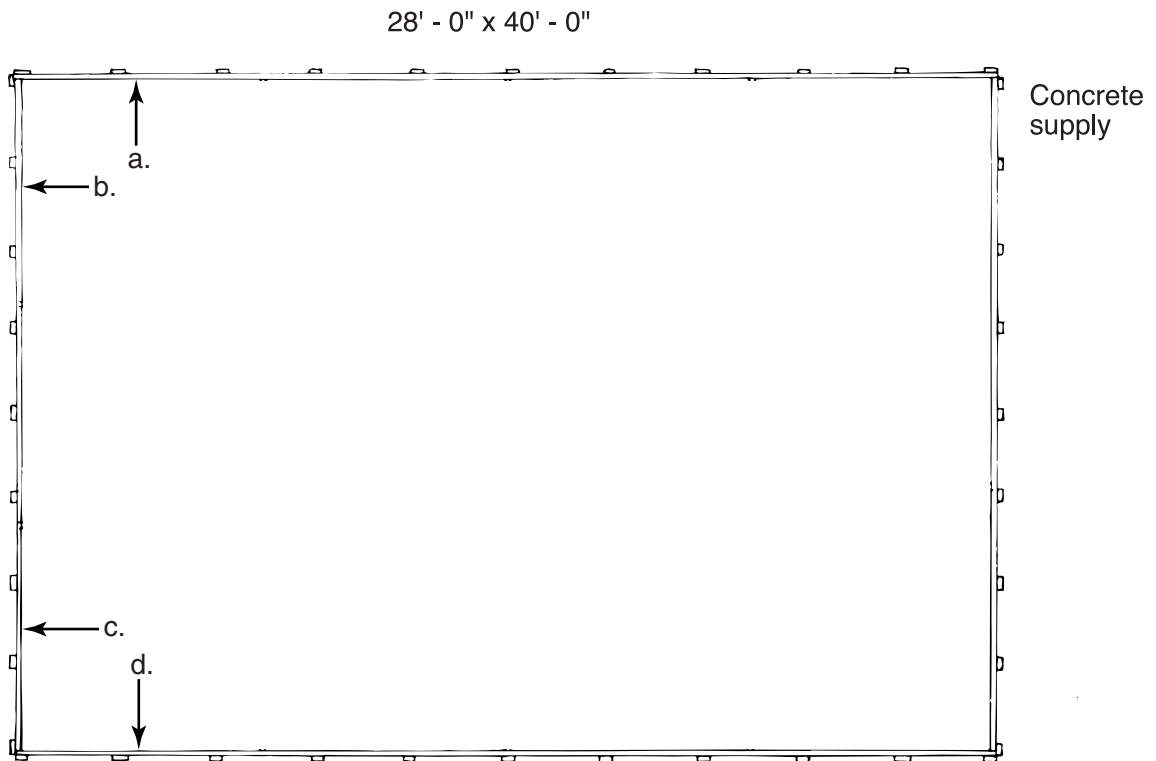

- In the next two illustrations, determine which supply location to use, then determine where to start placing concrete. Circle the letter indicating supply location and label it "S," then circle the letter indicating where to start placing concrete and label it "P." Be prepared to give reasons for your choices.

3.

30' - 0" x 42' - 0"

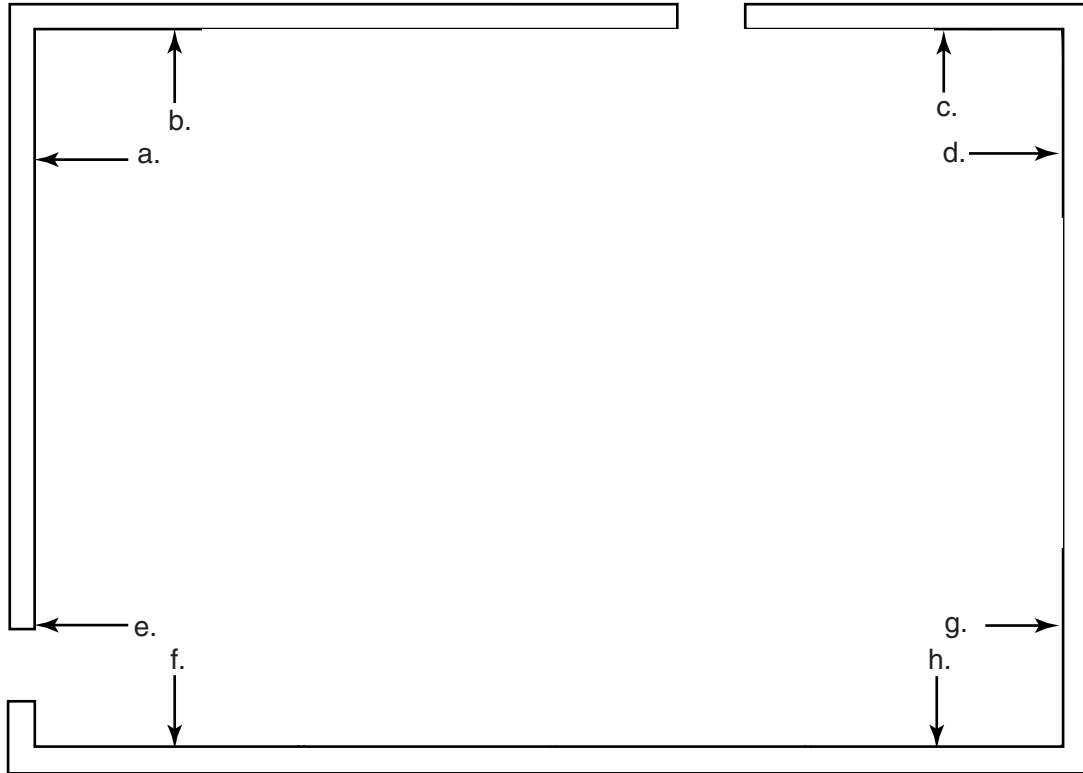

4.

